



ZT200 Series™



Industrial Printers

User Guide



© 2015 ZIH Corp. and/or its affiliates. All rights reserved. Zebra and the stylized Zebra head are trademarks of ZIH Corp., registered in many jurisdictions worldwide. All other trademarks are the property of their respective owners.

The copyrights in this manual and the software and/or firmware in the printer described therein are owned by ZIH Corp. and Zebra's licensors. Unauthorized reproduction of this manual or the software and/or firmware in the printer may result in imprisonment of up to one year and fines of up to \$10,000 (17 U.S.C.506). Copyright violators may be subject to civil liability.

This product may contain ZPL[®], ZPL II[®], Link-OS[™], and ZebraLink[™] programs; Element Energy Equalizer[®] Circuit; E³[®]; and Monotype Imaging fonts. Software © ZIH Corp. All rights reserved worldwide.

All other brand names, product names, or trademarks belong to their respective holders. For additional trademark information, please see “Trademarks” on the product CD.

Proprietary Statement This manual contains proprietary information of Zebra Technologies Corporation and its subsidiaries (“Zebra Technologies”). It is intended solely for the information and use of parties operating and maintaining the equipment described herein. Such proprietary information may not be used, reproduced, or disclosed to any other parties for any other purpose without the express, written permission of Zebra Technologies.

Product Improvements Continuous improvement of products is a policy of Zebra Technologies. All specifications and designs are subject to change without notice.

Liability Disclaimer Zebra Technologies takes steps to ensure that its published Engineering specifications and manuals are correct; however, errors do occur. Zebra Technologies reserves the right to correct any such errors and disclaims liability resulting therefrom.

Limitation of Liability In no event shall Zebra Technologies or anyone else involved in the creation, production, or delivery of the accompanying product (including hardware and software) be liable for any damages whatsoever (including, without limitation, consequential damages including loss of business profits, business interruption, or loss of business information) arising out of the use of, the results of use of, or inability to use such product, even if Zebra Technologies has been advised of the possibility of such damages. Some jurisdictions do not allow the exclusion or limitation of incidental or consequential damages, so the above limitation or exclusion may not apply to you.





Declaration of Conformity

We have determined that the Zebra printers identified as the

ZT210™, ZT220™, and ZT230™

manufactured by:

Zebra Technologies Corporation
3 Overlook Point
Lincolnshire, Illinois 60069 U.S.A.

Have been shown to comply with the applicable technical standards of the FCC

For Home, Office, Commercial, and Industrial use

If no unauthorized change is made in the equipment,
and if the equipment is properly maintained and operated.

Compliance Information

FCC Compliance Statement

This device complies with Part 15 of the FCC Rules. Operation is subject to the following two conditions:

1. This device may not cause harmful interference, and
2. This device must accept any interference received, including interference that may cause undesired operation.



Note • This equipment has been tested and found to comply with the limits for a Class B digital device, pursuant to part 15 of the FCC Rules. These limits are designed to provide reasonable protection against harmful interference in a residential installation. This equipment generates, uses, and can radiate radio frequency energy and, if not installed and used in accordance with the instructions, may cause harmful interference to radio communications. However, there is no guarantee that interference will not occur in a particular installation. If this equipment does cause harmful interference to radio or television reception, which can be determined by turning the equipment off and on, the user is encouraged to try to correct the interference by one or more of the following measures:

- Reorient or relocate the receiving antenna.
- Increase the separation between the equipment and receiver.
- Connect the equipment into an outlet on a circuit different from that to which the receiver is connected.
- Consult the dealer or an experienced radio/TV technician for help.

FCC Radiation Exposure Statement (for printers with RFID encoders)

This equipment complies with FCC radiation exposure limits set forth for an uncontrolled environment. This equipment should be installed and operated with minimum distance 20cm between the radiator and your body.

This transmitter must not be co-located or operating in conjunction with any other antenna or transmitter.

Canadian DOC Compliance Statement

This Class B digital apparatus complies with Canadian ICES-003.

Cet appareil numérique de la classe B est conforme à la norme NMB-003 du Canada.

Contents

- Declaration of Conformity 3**
 - Compliance Information 4
- About This Document 9**
 - Who Should Use This Document 10
 - How This Document Is Organized 10
- 1 • Introduction 11**
 - Printer Components 12
 - Control Panel 13
 - Navigating through Screens in the ZT230 Printer Display 15
 - Idle Display, Home Menu, and User Menus 17
 - Types of Media 19
 - Ribbon Overview 21
 - When to Use Ribbon 21
 - Coated Side of Ribbon 21
- 2 • Printer Setup and Operation 25**
 - Handling the Printer 26
 - Unpack and Inspect the Printer 26
 - Store the Printer 26
 - Ship the Printer 26
 - Select a Location for the Printer 27
 - Install the Printer Driver and Connect the Printer to the Computer 28
 - Install Zebra Setup Utilities 28
 - Connect a Computer to the Printer’s USB Port 37
 - Connect a Computer to the Printer’s Serial or Parallel Port 41
 - Connect to Your Network through the Printer’s Ethernet Port 49
 - Connect the Printer to Your Wireless Network 56

Select a Print Mode	62
Load the Ribbon	65
Load the Media	70
Final Steps for Tear-Off Mode	76
Final Steps for Peel-Off Mode (with or without Liner Take-Up)	78
Final Steps for Cutter Mode	84
Print a Test Label and Make Adjustments	87
3 • Printer Configuration and Adjustment	91
Changing Printer Settings	92
Print Settings	93
Calibration and Diagnostic Tools	100
Network Settings	109
Language Settings	114
Sensor Settings	118
Port Settings	120
Calibrate the Ribbon and Media Sensors	122
Adjust the Printhead Pressure	127
Adjust Ribbon Tension	130
Remove Used Ribbon	131
4 • Routine Maintenance	133
Cleaning Schedule and Procedures	134
Clean the Exterior, the Media Compartment, and the Sensors	135
Clean the Printhead and Platen Roller	136
Clean the Peel Assembly	140
Clean the Cutter Module	144
Replacing Printer Components	148
Ordering Replacement Parts	148
Recycling Printer Components	148
Lubrication	148
5 • Troubleshooting	149
Meaning of Indicator Lights	150
Printing Issues	152
Ribbon Problems	155
Error Messages	157
Communications Problems	161
Miscellaneous Issues	162

- Printer Diagnostics 164
 - Power-On Self Test 164
 - CANCEL Self Test 165
 - PAUSE Self Test 166
 - FEED Self Test 167
 - FEED + PAUSE Self Test 170
 - CANCEL + PAUSE Self Test 170
 - Communication Diagnostics Test 171
 - Sensor Profile 172
- 6 • Specifications 175**
 - General Specifications 176
 - Power Cord Specifications 178
 - Printing Specifications 180
 - Ribbon Specifications 180
 - Media Specifications 181
- Glossary 183**
- Index 187**

About This Document

This section provides you with contact information, document structure and organization, and additional reference documents.

Contents

Who Should Use This Document	10
How This Document Is Organized	10

Who Should Use This Document

This User Guide is intended for use by any person who needs to perform routine maintenance, upgrade, or troubleshoot problems with the printer.

How This Document Is Organized

The User Guide is set up as follows:

Section	Description
<i>Introduction on page 11</i>	This section provides a high-level overview of the printer and its components.
<i>Printer Setup and Operation on page 25</i>	This section assists the technician with initial setup and operation of the printer.
<i>Printer Configuration and Adjustment on page 91</i>	This section assists you with configuration of and adjustments to the printer.
<i>Routine Maintenance on page 133</i>	This section provides routine cleaning and maintenance procedures.
<i>Troubleshooting on page 149</i>	This section provides information about errors that you might need to troubleshoot. Assorted diagnostic tests are included.
<i>Specifications on page 175</i>	This section lists general printer specifications, printing specifications, ribbon specifications, and media specifications.
<i>Glossary on page 183</i>	The glossary provides a list of common terms.

Introduction

This section provides a high-level overview of the printer and its components.

Contents

Printer Components	12
Control Panel	13
Navigating through Screens in the ZT230 Printer Display	15
Idle Display, Home Menu, and User Menus	17
Types of Media	19
Ribbon Overview	21
When to Use Ribbon	21
Coated Side of Ribbon	21

Printer Components



Note • The components inside your printer are color-coded.

- The touch points that you will need to handle are colored **gold** inside the printers and are highlighted in **gold** in the illustrations in this manual.
- The components associated with the ribbon system are made of **black** plastic, while the components associated with media are made of **gray** plastic. Those components and others are highlighted in **light blue** in the illustrations in this manual as needed.

Figure 1 shows the components inside the media compartment of your printer. Depending on the printer model and the installed options, your printer may look slightly different. The components that are labeled are mentioned in procedures throughout this manual.

Figure 1 • Printer Components

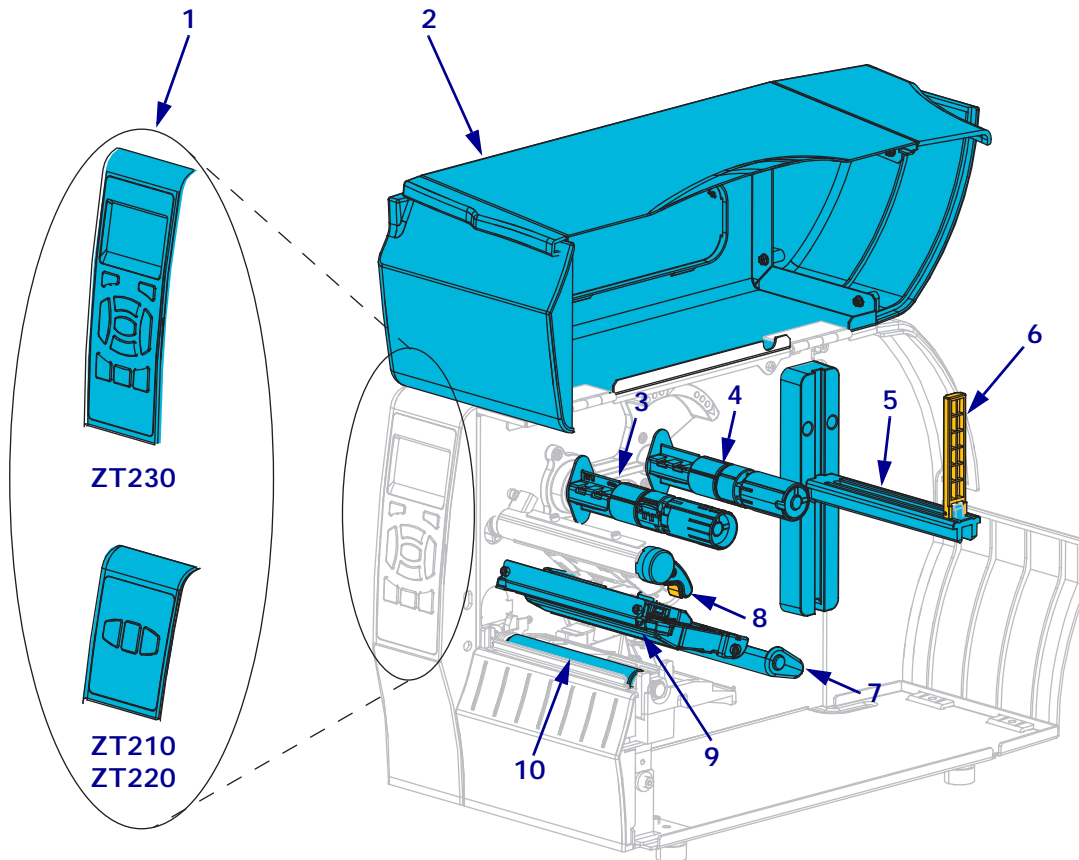

1	Control panel
2	Media door
3	Ribbon take-up spindle*
4	Ribbon supply spindle*
5	Media supply hanger

6	Media supply guide
7	Media dancer assembly
8	Printhead-open lever
9	Printhead assembly
10	Platen roller

* This component appears only in printers that have the Thermal Transfer option installed.

Control Panel

The control panel indicates the printer's current status and allows the user to control basic printer operation.

Figure 2 • ZT230 Printer Control Panel

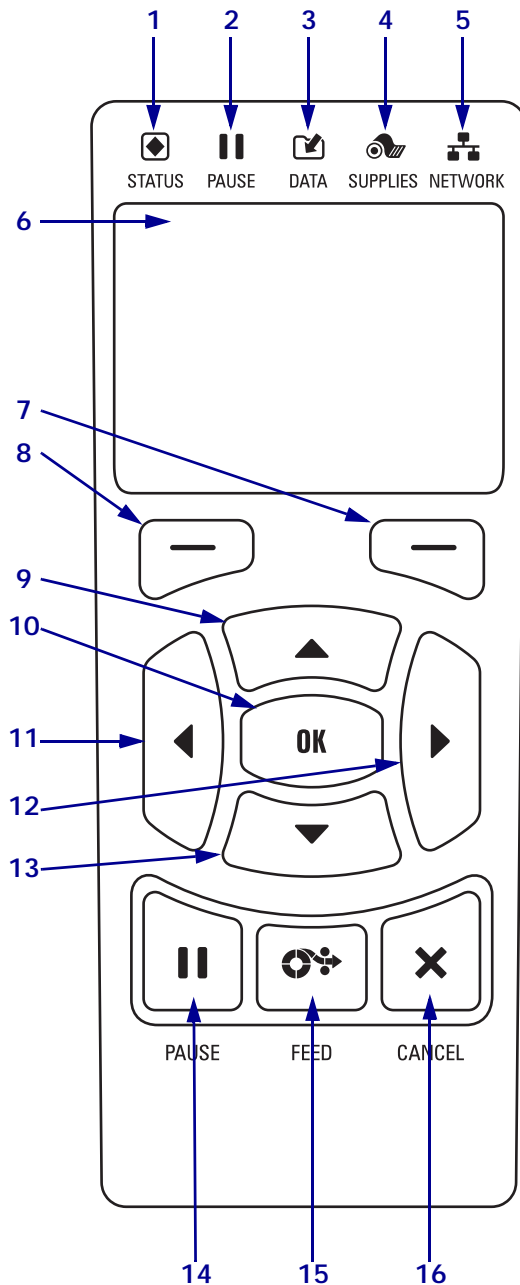

1	STATUS light	These indicator lights show the current status of the printer. For more information, see Table 12 on page 150 .
2	PAUSE light	
3	DATA light	
4	SUPPLIES light	
5	NETWORK light	
6	The display shows the printer's current status and allows the user to navigate the menu system.	
7	RIGHT SELECT button	These buttons execute the commands shown directly above them in the display.
8	LEFT SELECT button	
9	The UP ARROW button operates as follows in the menu system: <ul style="list-style-type: none"> Changes the parameter values. Common uses are to increase a value, to scroll through choices, or to change values while entering the printer password. Navigates up in a menu. The UP ARROW button changes the parameter values. Common uses are to increase a value or to scroll through choices.	
10	The OK button selects or confirms what is shown on the display.	
11	The LEFT ARROW button , which is active only in the menu system, navigates to the left.	
12	The RIGHT ARROW button , which is active only in the menu system, navigates to the right.	
13	The DOWN ARROW button operates as follows in the menu system: <ul style="list-style-type: none"> Changes the parameter values. Common uses are to decrease a value, to scroll through choices, or to change the cursor position while entering the printer password. Navigates down in a menu. The DOWN ARROW button changes the parameter values. Common uses are to decrease a value or to scroll through choices.	
14	The PAUSE button starts or stops printer operation when pressed.	
15	The FEED button forces the printer to feed one	

Figure 3 • ZT220 Printer Control Panel

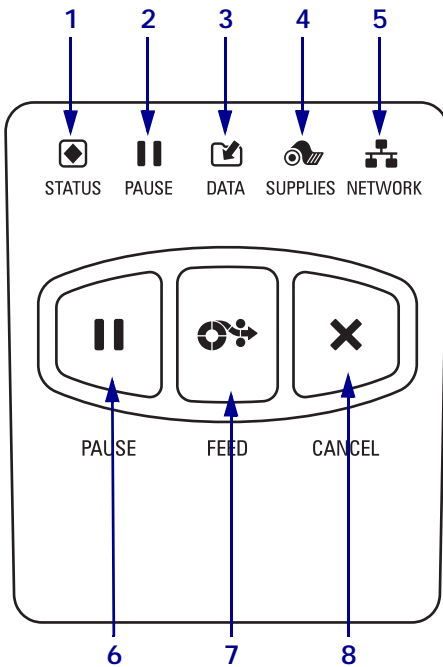

1	STATUS light	These indicator lights show the current status of the printer. For more information, see Table 12 on page 150 .
2	PAUSE light	
3	DATA light	
4	SUPPLIES light	
5	NETWORK light	
6	The PAUSE button starts or stops printer operation when pressed.	
7	The FEED button forces the printer to feed one blank label each time the button is pressed.	
8	The CANCEL button cancels label formats when the printer is paused. <ul style="list-style-type: none"> • Press once to cancel the next label format. • Press and hold for 2 seconds to cancel all label formats. 	

Figure 4 • ZT210 Printer Control Panel

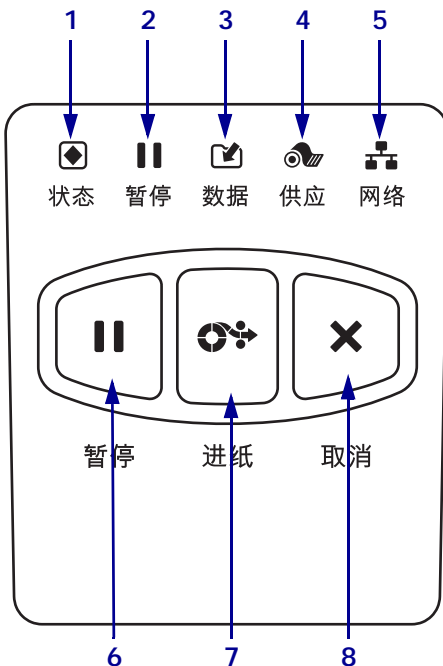

1	STATUS light	These indicator lights show the current status of the printer. For more information, see Table 12 on page 150 .
2	PAUSE light	
3	DATA light	
4	SUPPLIES light	
5	NETWORK light	
6	The PAUSE button starts or stops printer operation when pressed.	
7	The FEED button forces the printer to feed one blank label each time the button is pressed.	
8	The CANCEL button cancels label formats when the printer is paused. <ul style="list-style-type: none"> • Press once to cancel the next label format. • Press and hold for 2 seconds to cancel all label formats. 	

Navigating through Screens in the ZT230 Printer Display

Table 1 shows the following:

- the options available for navigating through the screens in the ZT230 printer control panel display
- how to select or modify things shown on the display

Table 1 • Navigation

Idle Display

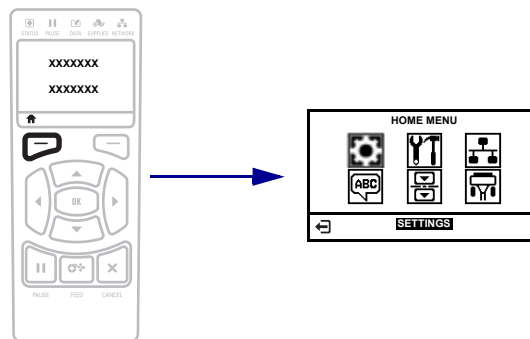

At the Idle Display (Figure 5 on page 17), press **LEFT SELECT** to go to the printer's Home menu (Figure 6 on page 17).

Home Menu



To move from icon to icon in the Home menu, press any of the **ARROW** buttons.

When an icon is selected, its colors are reversed to highlight it.



SETTINGS menu icon



SETTINGS menu icon highlighted



To select the highlighted menu icon and enter the menu, press **OK**.



Press **LEFT SELECT** to exit the Home menu and return to the Idle Display. The printer automatically returns to the Idle Display after 15 seconds of inactivity in the Home menu.

Table 1 • Navigation (Continued)

User Menus



Press **LEFT SELECT** to return to the Home menu. The printer automatically returns to the Home menu after 15 seconds of inactivity in a user menu.



▼ and ▲ indicate that a value can be changed. Any changes that you make are saved immediately.

Press the **UP ARROW** or **DOWN ARROW** to scroll through accepted values.



To scroll through the items in a user menu, press the **LEFT ARROW** or **RIGHT ARROW**.



A word in the bottom-right corner of the display indicates an available action.

Press **OK** or press **RIGHT SELECT** to perform the action shown.

Idle Display, Home Menu, and User Menus

In the Index, the term “Home menu” will not display properly. There will be a comma followed by a page number in the correct location, but the term will not be there. Need to manually type the term into the index after generating.

The ZT230 printer’s control panel includes a display, where you can view the printer’s status or change its operating parameters. In this section, you will learn how to navigate through the printer’s menu system and change values for menu items.

After the printer completes the power-up sequence, it moves to the Idle Display ([Figure 5](#)). If a print server is installed, the printer cycles through its IP address and information configured by the user.

Figure 5 • Idle Display

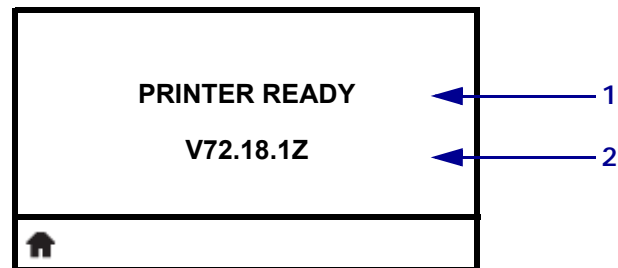

1	The printer’s current status
2	Information that you set through Idle Display on page 102
	Home menu shortcut

Home Menu Use the Home menu ([Figure 6](#)) to access the printer’s operating parameters through the six user menus ([Figure 7 on page 18](#)).

Figure 6 • Home Menu

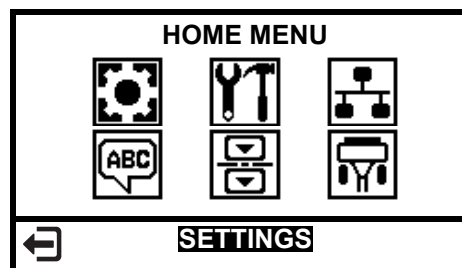

	Exit and return to the Idle Display (Figure 5).
---	---

User Menus The following are the user menus and the items that appear in each. Click any of the menu items to go to their descriptions.

Figure 7 • User Menus



* Denotes a shortcut to the next user menu

Types of Media



Important • Zebra strongly recommends the use of Zebra-brand supplies for continuous high-quality printing. A wide range of paper, polypropylene, polyester, and vinyl stock has been specifically engineered to enhance the printing capabilities of the printer and to prevent premature printhead wear. To purchase supplies, go to <http://www.zebra.com/howtobuy>.

Your printer can use various types of media:

- *Standard media*—Most standard media uses an adhesive backing that sticks individual labels or a continuous length of labels to a liner. Standard media can come on rolls or in a fanfold stack (Table 2).
- *Tag stock*—Tags are usually made from a heavy paper. Tag stock does not have adhesive or a liner, and it is typically perforated between tags. Tag stock can come on rolls or in a fanfold stack (Table 2).

Table 2 • Roll and Fanfold Media

Media Type	How It Looks	Description
<p>Non-Continuous Roll Media</p>		<p>Roll media is wound on a 3-in. (76-mm) core. Roll media is wound on a core that can be 1 in. to 3 in. (25 to 76 mm) in diameter. Individual labels or tags are separated by one or more of the following methods:</p> <ul style="list-style-type: none"> • <i>Web media</i> separates labels by gaps, holes, or notches.  • <i>Black mark media</i> uses pre-printed black marks on the back side of the media to indicate label separations.  • <i>Perforated media</i> has perforations that allow the labels or tags to be separated from each other easily. The media may also have black marks or other separations between labels or tags. 

Table 2 • Roll and Fanfold Media (Continued)

Media Type	How It Looks	Description
Non-Continuous Fanfold Media		<p>Fanfold media is folded in a zigzag pattern. Fanfold media can have the same label separations as non-continuous roll media. The separations would fall on or near the folds.</p>
Continuous Roll Media		<p>Roll media is wound on a 3-in. (76-mm) core. Roll media is wound on a core that can be 1 in. to 3 in. (25 to 76 mm) in diameter.</p> <p>Continuous roll media does not have gaps, holes, notches, or black marks to indicate label separations. This allows the image to be printed anywhere on the label. Sometimes a cutter is used to cut apart individual labels.</p>

Ribbon Overview

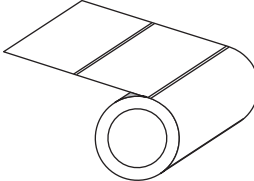
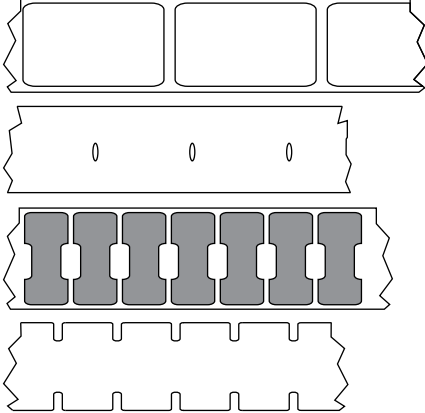
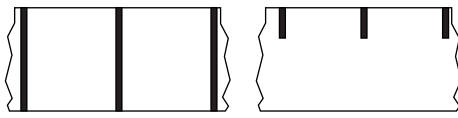
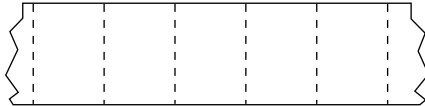
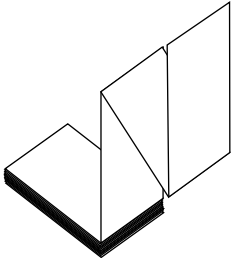
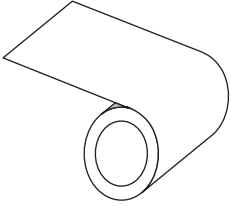

Note • This section applies only to printers that have the Thermal Transfer option installed.

Ribbon is a thin film that is coated on one side with wax, resin, or wax resin, which is transferred to the media during the thermal transfer process. The media determines whether you need to use ribbon and how wide the ribbon must be.

When ribbon is used, it must be as wide as or wider than the media being used. If the ribbon is narrower than the media, areas of the printhead are unprotected and subject to premature wear.

When to Use Ribbon

Thermal transfer media requires ribbon for printing while direct thermal media does not. To determine if ribbon must be used with a particular media, perform a media scratch test.

To perform a media scratch test, complete these steps:

1. Scratch the print surface of the media rapidly with your fingernail.
2. Did a black mark appear on the media?

If a black mark...	Then the media is...
Does not appear on the media	Thermal transfer. A ribbon is required.
Appears on the media	Direct thermal. No ribbon is required.

Coated Side of Ribbon

Ribbon can be wound with the coated side on the inside or outside (Figure 8). This printer can only use ribbon that is coated on the outside. If you are unsure which side of a particular roll of ribbon is coated, perform an adhesive test or a ribbon scratch test to determine which side is coated.

Figure 8 • Ribbon Coated on Outside or Inside







Ribbon can be wound with the coated side on the inside or outside. The ribbon used must match the Thermal Transfer option installed. The standard Thermal Transfer option (black ribbon spindle) uses ribbon coated on the outside, and the alternate Thermal Transfer option (gray ribbon spindle, available on the ZM400 and RZ400 only) uses ribbon coated on the inside. If you are unsure which side of a particular roll of ribbon is coated, perform an adhesive test or a ribbon scratch test to determine which side is coated.

Adhesive Test

If you have labels available, perform the adhesive test to determine which side of a ribbon is coated. This method works well for ribbon that is already installed.

To perform an adhesive test, complete these steps:

1. Peel a label from its liner.
2. Press a corner of the sticky side of the label to the outer surface of the roll of ribbon.
3. Peel the label off of the ribbon.
4. Observe the results. Did flakes or particles of ink from the ribbon adhere to the label?

If ink from the ribbon...	Then...
Adhered to the label	The ribbon is coated on the outside and can be used in this printer. 
Did not adhere to the label	The ribbon is coated on the inside and cannot be used in this printer. To verify this, repeat the test on the other surface of the roll of ribbon. 
Adhered to the label	The ribbon is coated on the outside and can be used with the standard Thermal Transfer option (black ribbon spindle). In the ribbon loading procedure, instructions are marked with this symbol. 
Did not adhere to the label	The ribbon is coated on the inside and can be used with the alternate Thermal Transfer option (gray ribbon spindle). In the ribbon loading procedure, instructions are marked with this symbol. 





Ribbon Scratch Test

Perform the ribbon scratch test when labels are unavailable.

To perform a ribbon scratch test, complete these steps:

1. Unroll a short length of ribbon.
2. Place the unrolled section of ribbon on a piece of paper with the outer surface of the ribbon in contact with the paper.

3. Scratch the inner surface of the unrolled ribbon with your fingernail.
4. Lift the ribbon from the paper.
5. Observe the results. Did the ribbon leave a mark on the paper?

If the ribbon...	Then...
Left a mark on the paper	The ribbon is coated on the outside and can be used in this printer. 
Did not leave a mark on the paper	The ribbon is coated on the inside and cannot be used in this printer. To verify this, repeat the test on the other surface of the roll of ribbon. 
Left a mark on the paper	The ribbon is coated on the outside and can be used with the standard Thermal Transfer option (black ribbon spindle). In the ribbon loading procedure, instructions are marked with this symbol. 
Did not leave a mark on the paper	The ribbon is coated on the inside and can be used with the alternate Thermal Transfer option (gray ribbon spindle). In the ribbon loading procedure, instructions are marked with this symbol. 

Printer Setup and Operation

This section assists the technician with initial setup and operation of the printer.

Contents

Handling the Printer	26
Unpack and Inspect the Printer	26
Store the Printer	26
Ship the Printer	26
Select a Location for the Printer	27
Install the Printer Driver and Connect the Printer to the Computer	28
Install Zebra Setup Utilities	28
Connect a Computer to the Printer's USB Port	37
Connect a Computer to the Printer's Serial or Parallel Port	41
Connect to Your Network through the Printer's Ethernet Port	49
Connect the Printer to Your Wireless Network	56
Select a Print Mode	62
Load the Ribbon	65
Load the Media	70
Final Steps for Tear-Off Mode	76
Final Steps for Peel-Off Mode (with or without Liner Take-Up)	78
Final Steps for Cutter Mode	84

Handling the Printer

This section describes how to handle your printer.

Unpack and Inspect the Printer

When you receive the printer, immediately unpack it and inspect for shipping damage.

- Save all packing materials.
- Check all exterior surfaces for damage.
- Raise the media door, and inspect the media compartment for damage to components.

If you discover shipping damage upon inspection:

- Immediately notify the shipping company and file a damage report.
- Keep all packaging material for shipping company inspection.
- Notify your authorized Zebra reseller



Important • Zebra Technologies is not responsible for any damage incurred during the shipment of the equipment and will not repair this damage under warranty.

Store the Printer

If you are not placing the printer into immediate operation, repackage it using the original packing materials. You may store the printer under the following conditions:

- Temperature: –40°F to 140°F (–40° to 60°C)
- Relative humidity: 5% to 85% non-condensing

Ship the Printer

If you must ship the printer:

- Turn off (O) the printer, and disconnect all cables.
- Remove any media, ribbon, or loose objects from the printer interior.
- Close the printhead.
- Carefully pack the printer into the original container or a suitable alternate container to avoid damage during transit. A shipping container can be purchased from Zebra if the original packaging has been lost or destroyed.

Select a Location for the Printer

Select a location for the printer that meets these conditions:

- **Surface:** The surface where the printer will be located must be solid, level, and of sufficient size and strength to hold the printer.
- **Space:** The area where the printer will be located must include enough space for ventilation and for accessing the printer components and connectors. To allow for proper ventilation and cooling, leave open space on all sides of the printer.



Caution • Do not place any padding or cushioning material behind or under the printer because this restricts air flow and could cause the printer to overheat.

- **Power:** The printer should be within a short distance of an appropriate power outlet that is easily accessible.
- **Data communication interfaces:** The printer must be within range of your WLAN radio (if applicable) or within an acceptable range for other connectors to reach your data source (usually a computer). For more information on maximum cable lengths and configuration, see [Table on page 176](#).
- **Operating conditions:** Your printer is designed to function in a wide range of environmental and electrical conditions, including a warehouse or factory floor. [Table 3](#) shows the temperature and relative humidity requirements for the printer when it is operating.

Table 3 • Operating Temperature and Humidity

Mode	Temperature	Relative Humidity
Thermal Transfer	41° to 104°F (5° to 40°C)	20 to 85% non-condensing
Direct Thermal	32° to 104°F (0° to 40°C)	

Install the Printer Driver and Connect the Printer to the Computer

In this section, you are shown how to use the Zebra Setup Utilities program to prepare a computer running Microsoft Windows® for the printer driver before connecting the printer to any of the computer's data communication interfaces. Use this section for directions to install this program if you have not already done so. You may connect your printer to your computer using any of the connections that you have available.



Important • You must install the Zebra Setup Utilities program before connecting the printer to your computer. Your computer will not install the correct printer drivers if you connect the printer to it without the Zebra Setup Utilities program.

Install Zebra Setup Utilities

Follow the directions in this section if you do not have Zebra Setup Utilities installed on your computer or if you want to update an existing version of the program. You do not need to uninstall any older versions or any Zebra printer drivers to do so.

To install the Zebra Setup Utilities program, complete these steps:

Download the Zebra Setup Utilities Installer

1. Go to <http://www.zebra.com/setup>.

The Zebra Setup Utilities page appears.

MYZEBRA LOGIN | PARTNER LOGIN

ZEBRA SOLUTIONS PRODUCTS SERVICES SUPPORT & DOWNLOADS PARTNERS

Home > Products > Software > Barcode Printers > ZebraLink

ZEBRA SETUP UTILITIES

The free Zebra Setup Utilities will enhance your out of the box printer experience by enabling you to quickly and easily configure select Zebra industrial, mobile and desktop printers. Wizards quickly guide you through the printer setup utility, whether you're adding a new printer, moving an existing printer to a new location or adding new capabilities.

[Register Your Software >](#)
[Download the Zebra Setup Utilities Brochure >](#)
[Compatible Printers](#)

[Find a Partner](#) [Contact Zebra](#)

DOWNLOADS DETAILED SPECS RESEARCH & LEARN SOFTWARE TUTORIALS

DOWNLOAD ZEBRA SETUP UTILITIES V1.1.9.1137 (8MB)

[Download >](#)

- On the DOWNLOADS tab, click Download under the ZEBRA SETUP UTILITIES option.



You are prompted to read and accept the End User License Agreement (EULA).

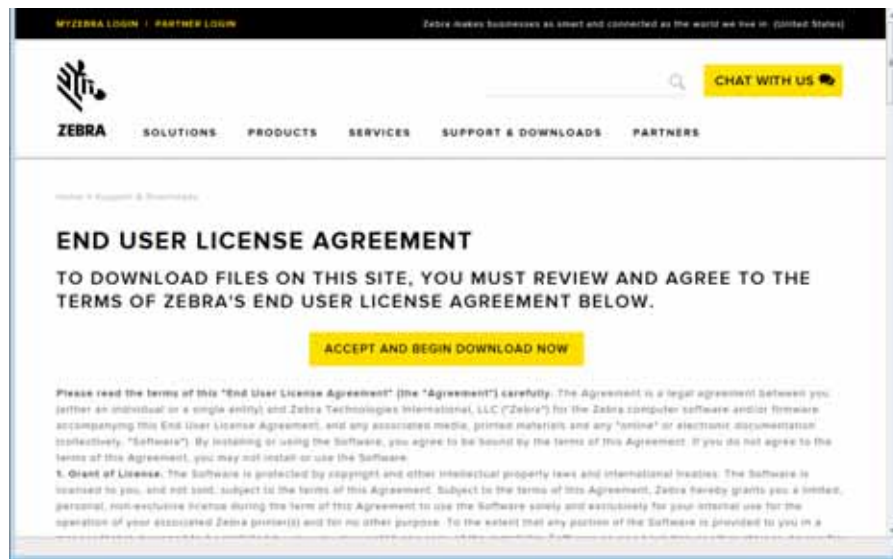

- If you agree with the terms of the EULA, click **ACCEPT AND BEGIN DOWNLOAD NOW**

Depending on your browser, you are given options to run or save the executable file.

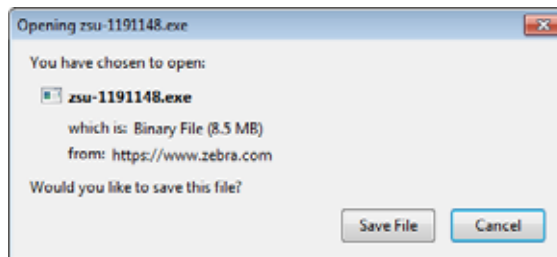
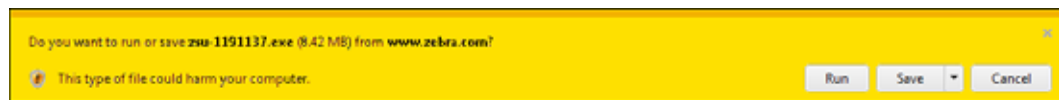

Run the Zebra Setup Utilities Installer

4. Save the program to your computer. (Optional if your browser gave you the option to run the program instead of saving it.)
5. Run the executable file. If your computer prompts you for permission to run the file, click the appropriate button to allow it to run.

What the computer displays next depends on whether Zebra Setup Utilities was already installed. Follow the instructions based on what your computer prompts you to do.

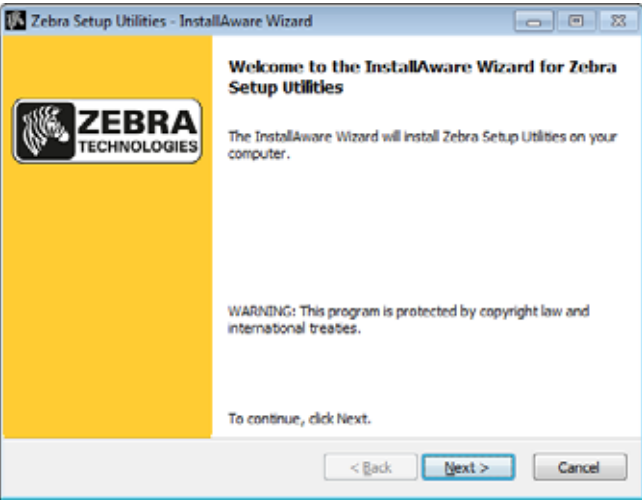
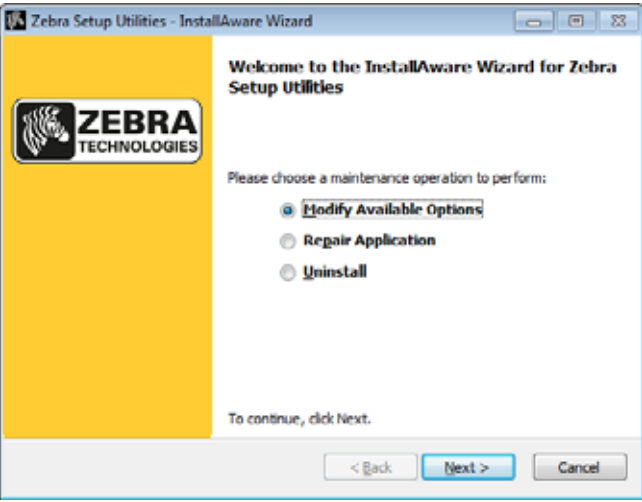
If your computer...	Then...
<p>Did not previously have the Zebra Setup Utilities installed</p>	<p>a. The Zebra Setup Utilities - InstallAware Wizard displays the following.</p>  <p>b. Continue with <i>New Installations of Zebra Setup Utilities</i> on page 31.</p>
<p>Did previously have the Zebra Setup Utilities installed</p>	<p>a. The Zebra Setup Utilities - InstallAware Wizard displays the following.</p>  <p>b. Continue with <i>Updating Existing Installations of Zebra Setup Utilities</i> on page 33.</p>

New Installations of Zebra Setup Utilities

6. Click Next.

You are prompted again to read and accept the End User License Agreement (EULA).

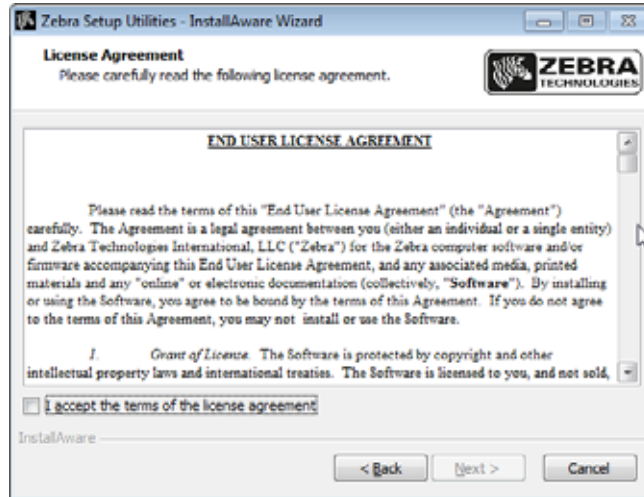

7. If you agree with the terms of the EULA, check the box that says I accept the terms of the license agreement

8. Click Next.

You are prompted to select where the files will be installed.

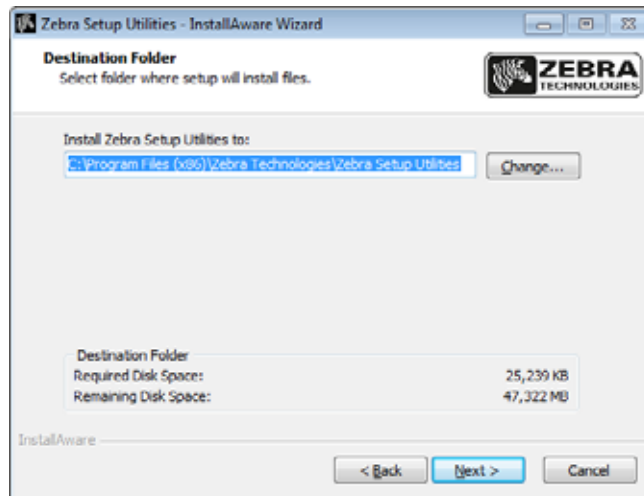

32 | Printer Setup and Operation

Install the Printer Driver and Connect the Printer to the Computer

9. Change the destination folder, if necessary, and then click Next.

You are prompted to select a location for program shortcuts.

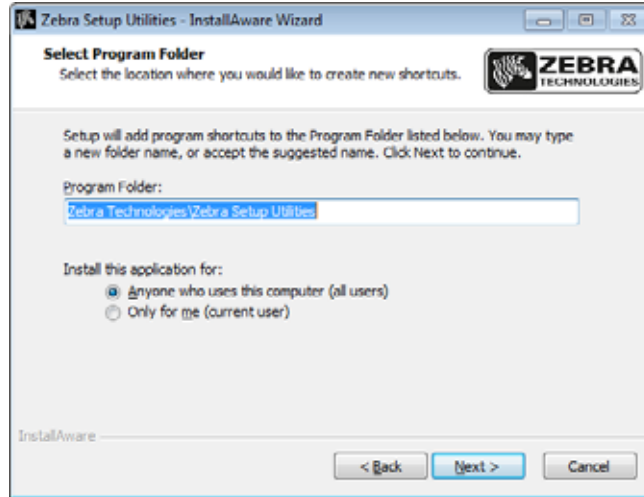

10. Change the location, if desired, and then click Next.

You are prompted to complete the InstallAware wizard.

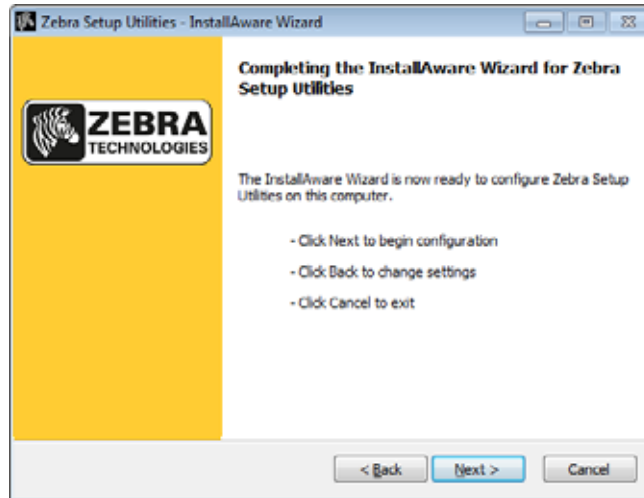

11. Skip to [Continuing with New or Updated Installations](#) on page 34.

Updating Existing Installations of Zebra Setup Utilities

12. Click Next.

You are prompted to choose the features that you would like to install.

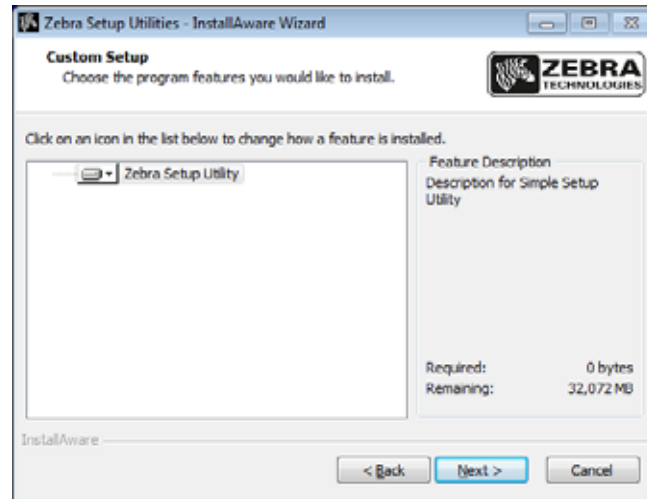

13. Click Next.

You are prompted to complete the InstallAware wizard.

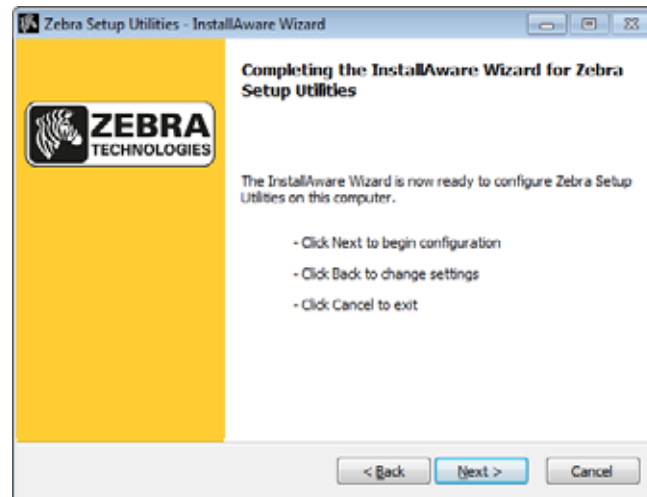

Continuing with New or Updated Installations

14. Click Next.

Installation begins.

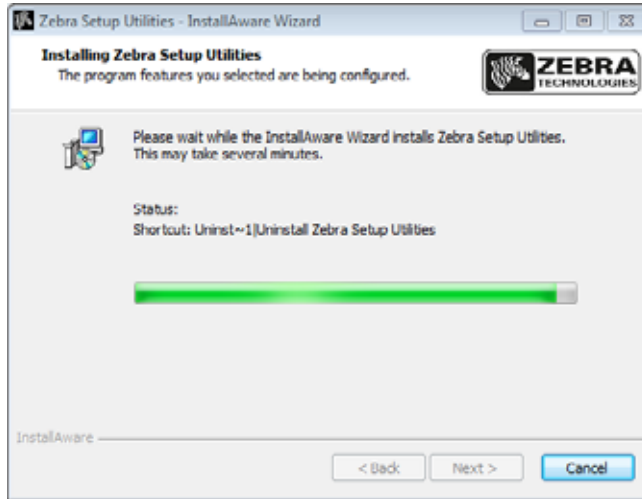

During installation, you are presented with information about drivers.

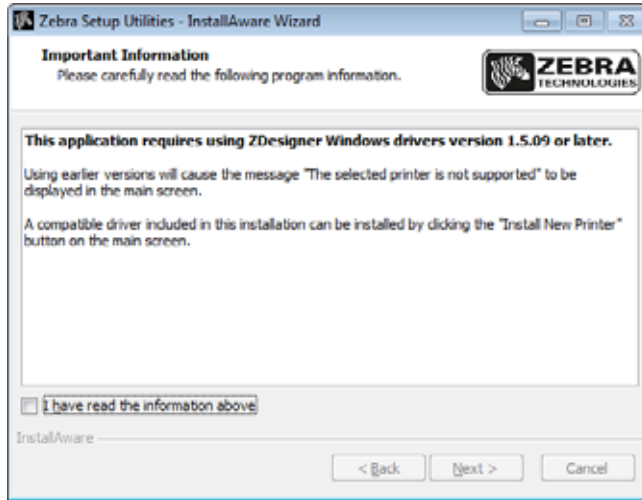

15. Read the information, and then check the box that says
I have read the information above

16. Click Next.

You are shown options that can take place when the wizard exits the installation.

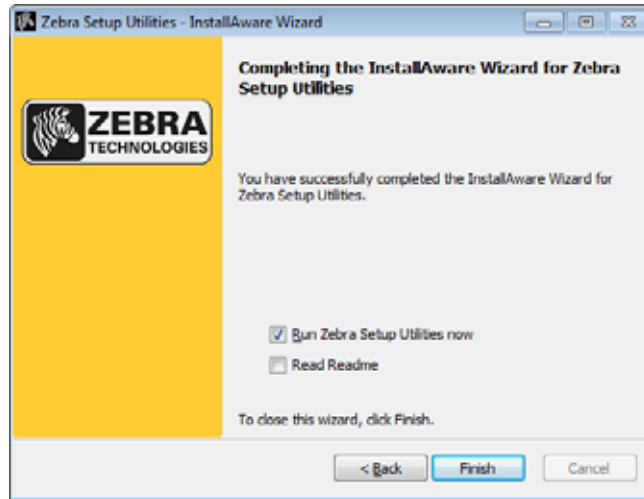

17. Check the box that says “Run Zebra Setup Utilities now.”

18. Click Finish.

What the computer displays next depends on whether any Zebra printer drivers are already installed on your computer. Follow the instructions based on what your computer displays.

If your computer...	Then...	
Did not previously have any Zebra printer drivers installed	The System Prepare Wizard displays. <div data-bbox="699 1150 1227 1522" style="border: 1px solid gray; padding: 5px; margin: 10px auto; width: fit-content;"> </div>	
	To connect by...	Then...
	USB port	Continue with <i>Connect a Computer to the Printer's USB Port</i> on page 37.
	Serial or optional parallel port	Continue with <i>Connect a Computer to the Printer's Serial or Parallel Port</i> on page 41.

36 | Printer Setup and Operation
 Install the Printer Driver and Connect the Printer to the Computer

<p>If your computer...</p>	<p>Then...</p>	
<p>Did previously have any Zebra printer drivers installed</p>	<p>The Zebra Setup Utilities screen displays.</p> 	
	<p>To connect by the...</p>	<p>Then...</p>
<p>USB port</p>	<p>Continue with <i>Connecting the printer to a USB port on your computer</i> on page 38.</p>	
<p>Serial or optional parallel port</p>	<p>Continue with <i>Adding a Printer from the Zebra Setup Utilities Screen</i> on page 44.</p>	

Connect a Computer to the Printer's USB Port

Complete the steps in this section only after you have installed the Zebra Setup Utilities program. If necessary, complete the steps in [Install Zebra Setup Utilities on page 28](#) before continuing.



Important • You must install the Zebra Setup Utilities program before connecting the printer to your computer. Your computer will not install the correct printer drivers if you connect the printer to it without the Zebra Setup Utilities program.

Caution • Ensure that the printer power is off (O) before connecting data communications cables. Connecting a data communications cable while the power is on (I) may damage the printer.

To connect the printer to your computer by USB, complete these steps:

Running the System Prepare Wizard

If you are at the Zebra Setup Utilities screen, you do not need to complete this section. Continue with [Connecting the printer to a USB port on your computer on page 38](#).

The first time that you install the Zebra Setup Utilities program and printer drivers, you are prompted to follow the System Prepare Wizard.

Figure 9 • System Prepare Wizard

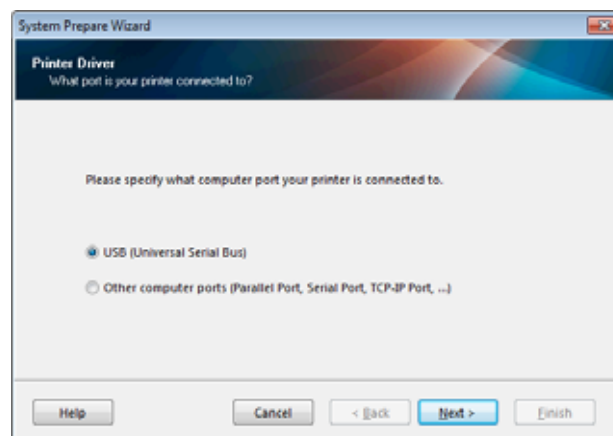

38 | Printer Setup and Operation

Install the Printer Driver and Connect the Printer to the Computer—USB

1. Click Next.

The System Prepare Wizard prompts you to connect the printer to the USB port on your computer.



2. Click Finish.

The Zebra Setup Utilities screen displays.

Connecting the printer to a USB port on your computer

Complete the steps in this section only after the System Prepare Wizard prompts you to do so or after you have opened the Zebra Setup Utilities program. If necessary, complete the steps in [Install Zebra Setup Utilities on page 28](#) before continuing.

Figure 10 • Zebra Setup Utilities Screen



3. Connect the USB cord to the USB port on your printer.

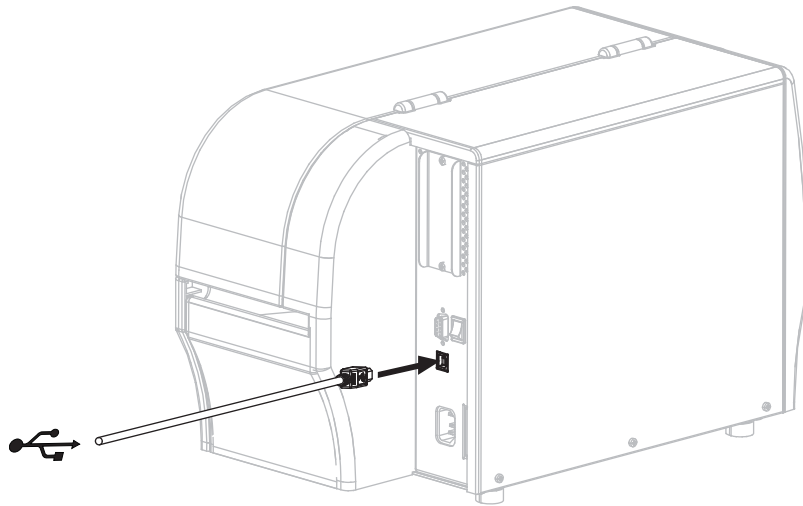

4. Connect the other end of the USB cord to your computer.
5. Plug the female end of the A/C power cord into the A/C power connector on the back of the printer.

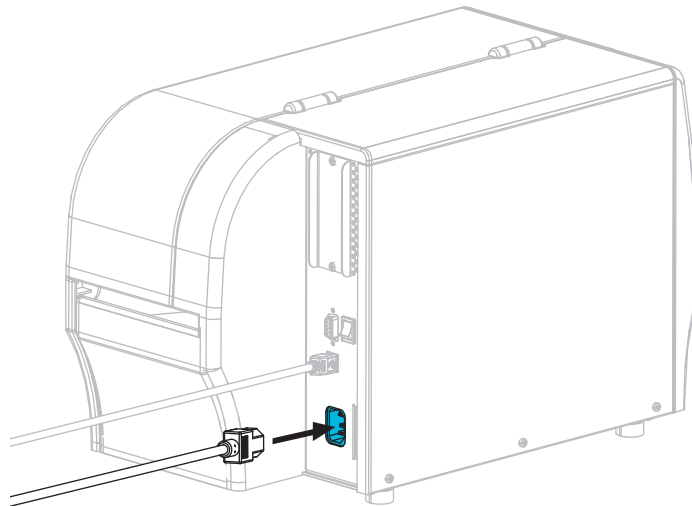

6. Plug the male end of the A/C power cord into an appropriate power outlet.

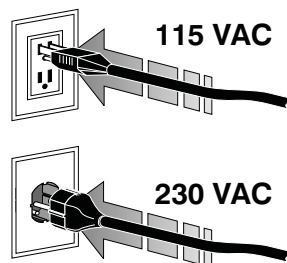

40 | Printer Setup and Operation

Install the Printer Driver and Connect the Printer to the Computer—USB

7. Turn on (I) the printer.

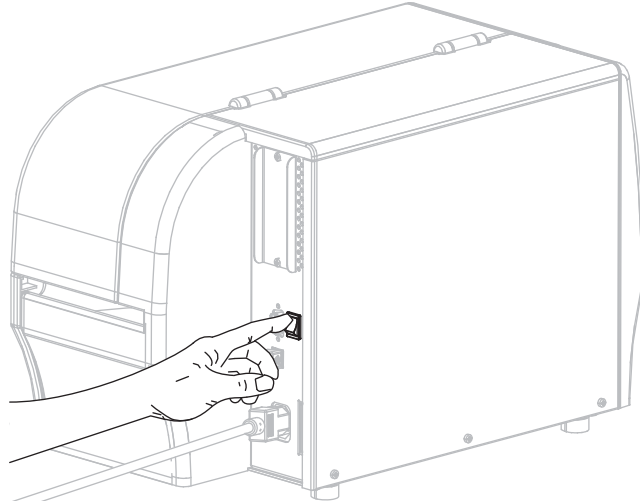

As the printer boots up, your computer completes the driver installation and recognizes your printer.

The installation for the USB connection is complete.

Connect a Computer to the Printer's Serial or Parallel Port

Complete the steps in this section only after you have installed the Zebra Setup Utilities program. If necessary, complete the steps in [Install Zebra Setup Utilities on page 28](#) before continuing.



Important • You must install the Zebra Setup Utilities program before connecting the printer to your computer. Your computer will not install the correct printer drivers if you connect the printer to it without the Zebra Setup Utilities program.

Caution • Ensure that the printer power is off (O) before connecting data communications cables. Connecting a data communications cable while the power is on (I) may damage the printer.

To connect the printer to your computer by USB, complete these steps:

If you are at the Zebra Setup Utilities screen, you do not need to complete this section. Continue with [Adding a Printer from the Zebra Setup Utilities Screen on page 44](#).

Running the System Prepare Wizard

The first time that you install the Zebra Setup Utilities program and printer drivers, you are prompted to follow the System Prepare Wizard.

Figure 11 • System Prepare Wizard

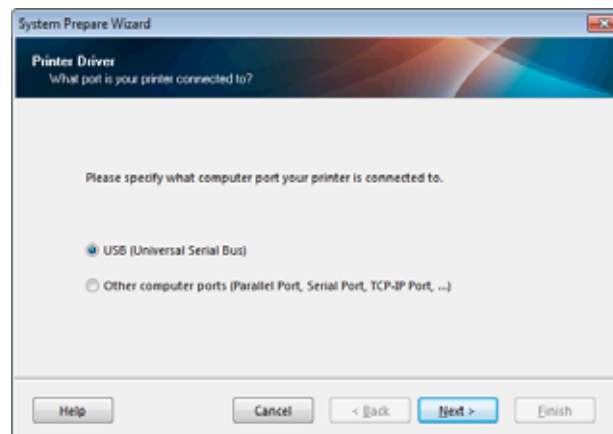

42 | Printer Setup and Operation

Install the Printer Driver and Connect the Printer to the Computer—Serial or Parallel

1. Select “Other computer ports (Parallel Port, Serial Port, TCP-IP Port, ...), and then click Next.

The new printer wizard prompts you to begin the installation procedure.

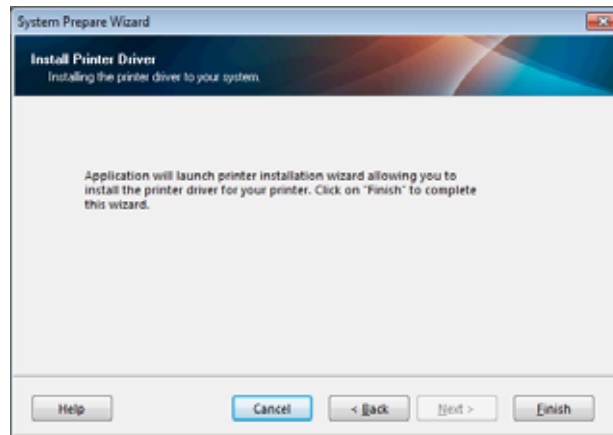

2. Click Finish.

The printer driver wizard displays.

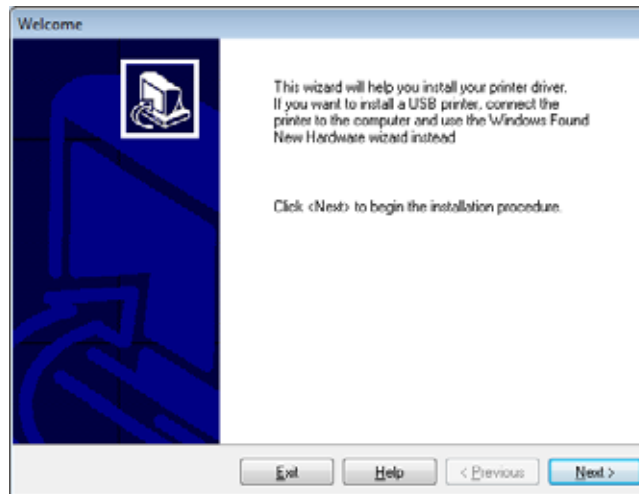

3. Click Next.

You are prompted to select an installation option.

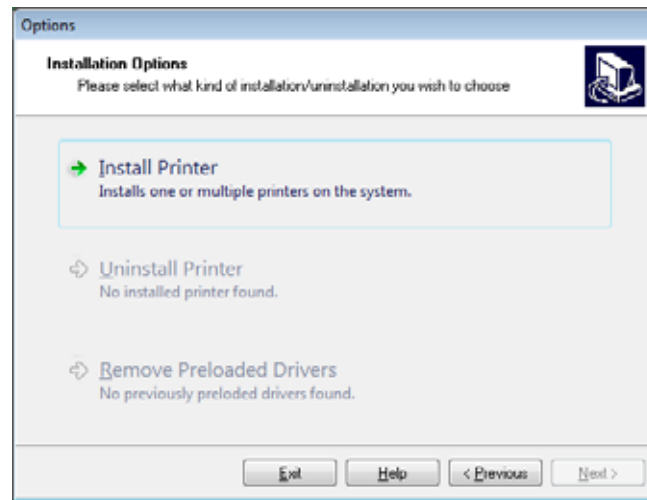
**4.** Continue with [step 6 on page 45](#).

44 | Printer Setup and Operation

Install the Printer Driver and Connect the Printer to the Computer—Serial or Parallel

Adding a Printer from the Zebra Setup Utilities Screen

Figure 12 • Zebra Setup Utilities Screen



5. On the Zebra Setup Utilities screen, click Install New Printer.
You are prompted to select an installation option.

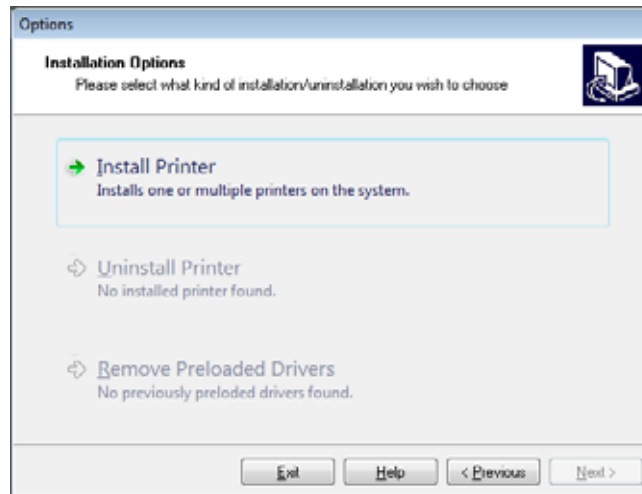

6. Click Install Printer.

You are prompted to select a printer type.

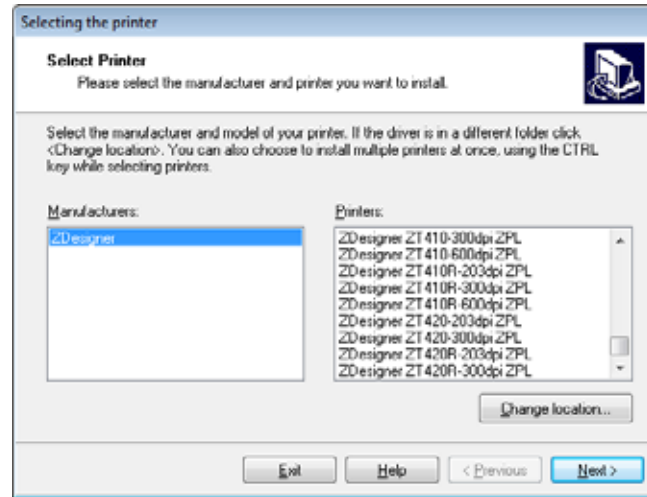

7. Select your printer model and resolution.

The model and resolution are on a part number sticker on the printer, usually located below the media hanger. The information will be in the following format:

Part Number: *XXXXXX*Y – xxxxxxxx

where

XXXXXX = the printer model

Y = the printer resolution (2 = 203 dpi, 3 = 300 dpi, 6 = 600 dpi)

For example, in the part number **ZT420x3** – xxxxxxxx

ZT420 indicates that the printer is a ZT420 model

3 indicates that the printhead resolution is 300 dpi

8. Click Next.

You are prompted for a printer name, the port to which the printer will be connected, and the language for the program.

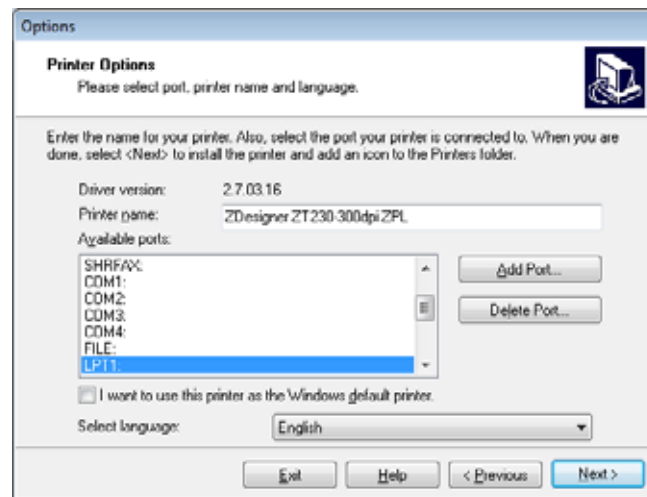

9. Change the printer name (if desired), and select the appropriate port and language.

46 | Printer Setup and Operation

Install the Printer Driver and Connect the Printer to the Computer—Serial or Parallel

10. Click Next.

You are prompted to launch other setup wizards.

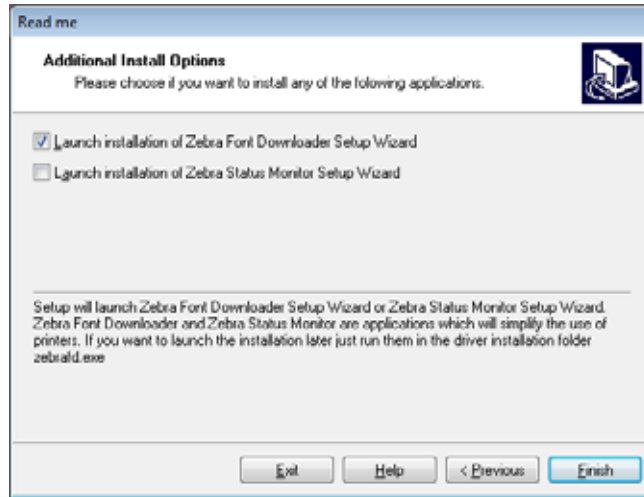

11. Check the desired options, and then click Finish.

The printer driver is installed. If you are prompted that other programs might be affected, click Next.

Connecting the printer to a serial or parallel port on your computer

12. Connect the desired cord to the appropriate port on your printer.

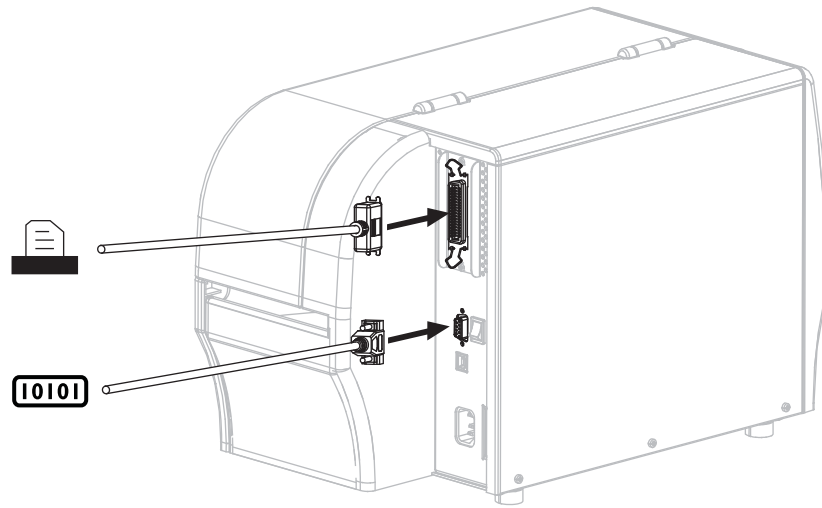

13. Connect the other end of the cord to the appropriate port on your computer.
14. Plug the female end of the A/C power cord into the A/C power connector on the back of the printer.

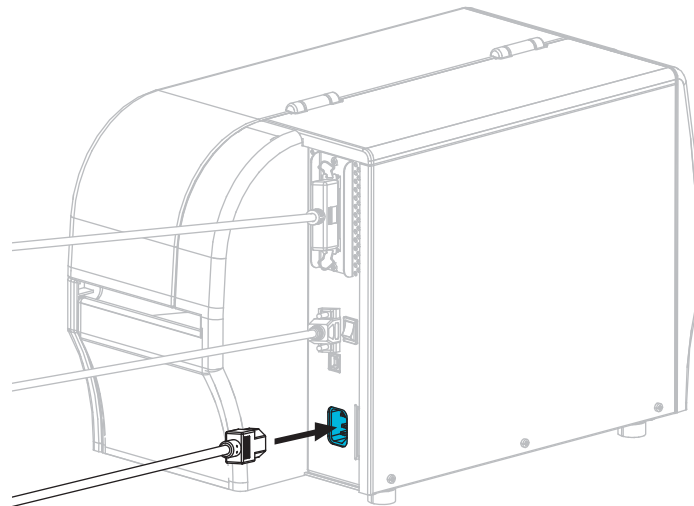

15. Plug the male end of the A/C power cord into an appropriate power outlet.

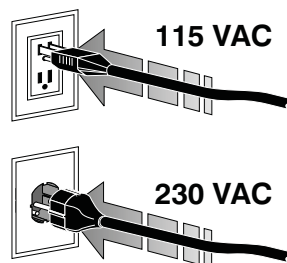

48 | Printer Setup and Operation

Install the Printer Driver and Connect the Printer to the Computer—Serial or Parallel

16. Turn on (I) the printer.

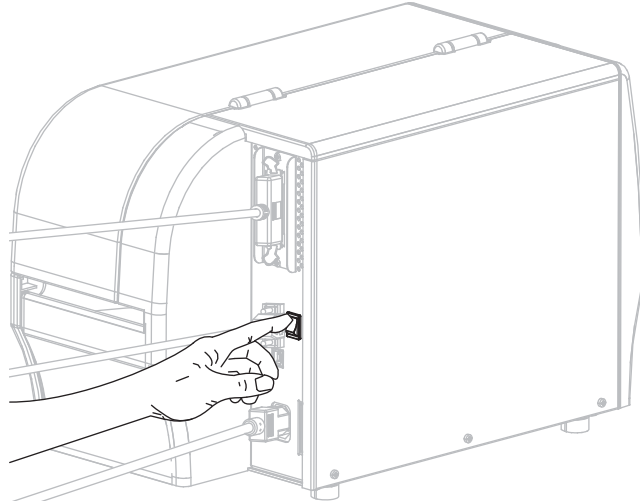

The printer boots up.

Configuring the printer (if necessary)

17. If necessary, adjust the printer's port settings to match those of your computer. For more information, see [Port Settings](#) on page 120.

The installation for serial or parallel connections is complete.

Connect to Your Network through the Printer's Ethernet Port

If you wish to use a wired print server (Ethernet) connection, you may need to connect the printer to your computer using one of the other available connections. While the printer is connected via one of those connections, you would configure the printer to communicate with your Local Area Network (LAN) through the printer's wired print server.

For additional information about Zebra print servers, refer to the *ZebraNet Wired and Wireless Print Server User Guide*. To download the latest version of this guide, go to <http://www.zebra.com/zt200-info>.



To connect the printer to your computer by a wired print server, complete these steps:

1. Install Zebra Setup Utilities as instructed in *Install Zebra Setup Utilities* on page 28.
2. Connect the printer to an Ethernet cable that is connected to your network.

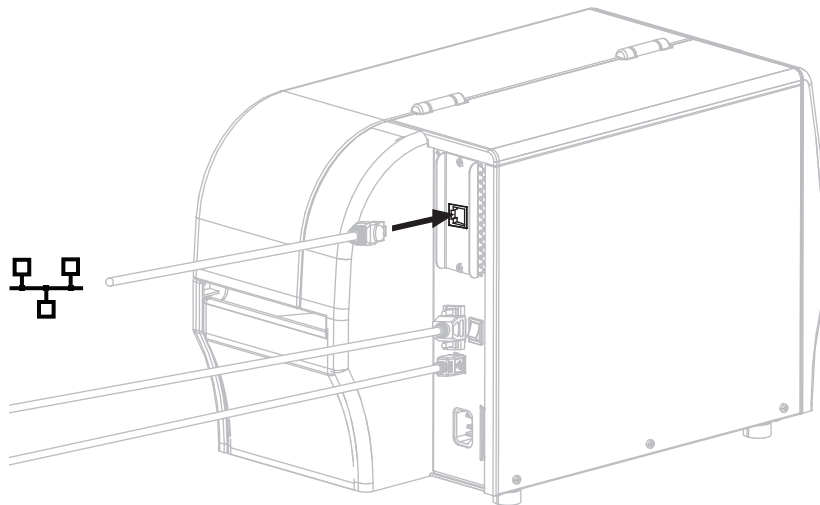

The printer attempts to communicate with your network. If it is successful, it fills in your LAN's gateway and subnet values and gets an IP address. The printer display will alternate between the printer's firmware version and its IP address.

3. Check the display to see if an IP address was assigned to the printer. See *IP Address* on page 109 for additional ways to view the IP address.

If the printer's IP address is...	Then...
0.0.0.0 or 000.000.000.000	Continue with <i>Configuring the printer with your LAN information (if necessary)</i> on page 50.
any other value	Continue with <i>Adding a Printer from the Zebra Setup Utilities Screen</i> on page 51.

Configuring the printer with your LAN information (if necessary)

If your printer connected to your network automatically, you do not need to complete this section. Continue with [Adding a Printer from the Zebra Setup Utilities Screen on page 51](#).

4. Connect the printer to your computer using a USB, serial, or optional parallel port as instructed in [Connect a Computer to the Printer's USB Port on page 37](#) or [Connect a Computer to the Printer's Serial or Parallel Port on page 41](#).
5. Configure the following printer settings. You can change the values through the Zebra Setup Utilities (click Configure Printer Connectivity on the Zebra Setup Utilities screen) or by the ways listed at the following links. Contact your network administrator for the proper values for your network.
 - [IP Protocol on page 111](#) (change the value from ALL to PERMANENT)
 - [Gateway on page 110](#) (match the gateway value of your LAN)
 - [Subnet Mask on page 109](#) (match the subnet value of your LAN)
 - [IP Address on page 109](#) (assign a unique IP address to the printer)

Adding a Printer from the Zebra Setup Utilities Screen

- If necessary, open the Zebra Setup Utilities program.
The Zebra Setup Utilities screen displays.

Figure 13 • Zebra Setup Utilities Screen



- Click Install New Printer.
The printer driver wizard displays.

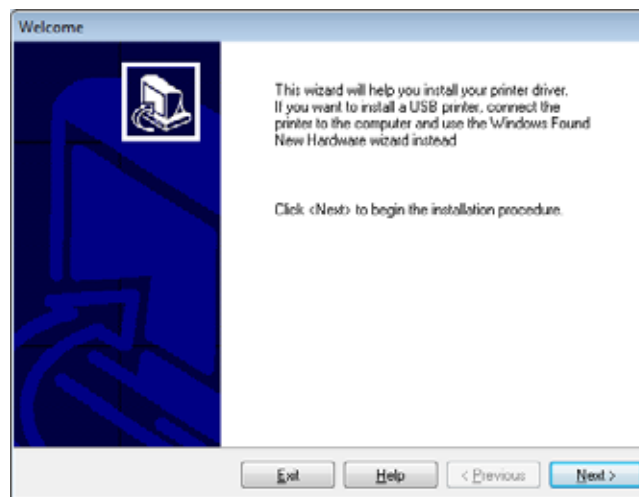

8. Click Next.

You are prompted to select an installation option.

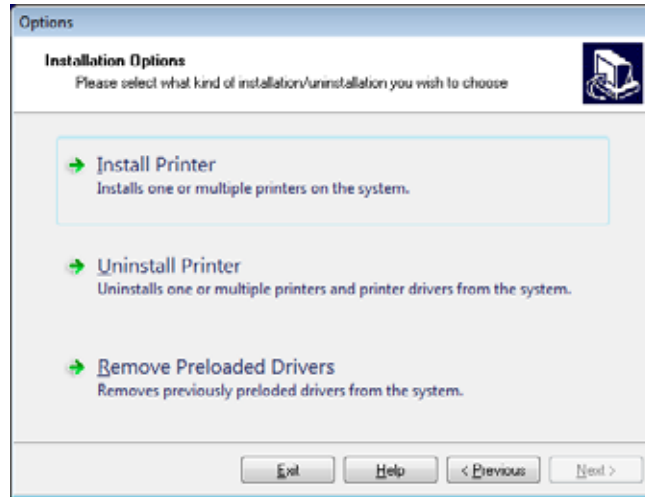

9. Click Install Printer.

You are prompted to select a printer type.

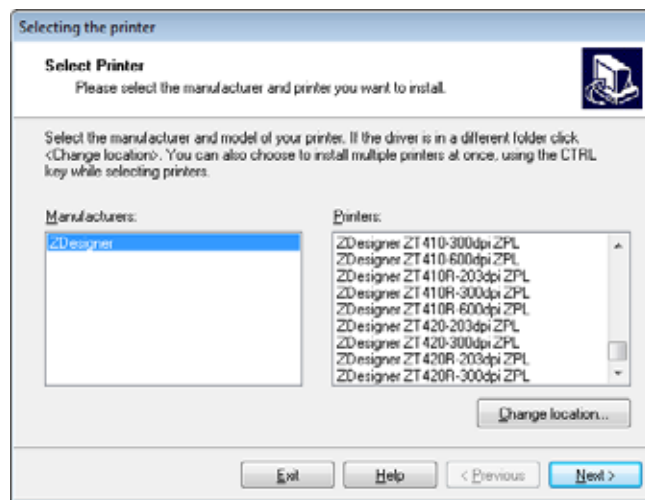

10. Select your printer model and resolution.

The model and resolution are on a part number sticker on the printer, usually located below the media hanger. The information will be in the following format:

Part Number: **XXXXX***Y* – xxxxxxxx

where

XXXXX = the printer model

Y = the printer resolution (2 = 203 dpi, 3 = 300 dpi, 6 = 600 dpi)

For example, in the part number **ZT230x3** – xxxxxxxx

ZT230 indicates that the printer is a ZT230 model

3 indicates that the printhead resolution is 300 dpi

11. Click Next.

You are notified that the printer is already installed.

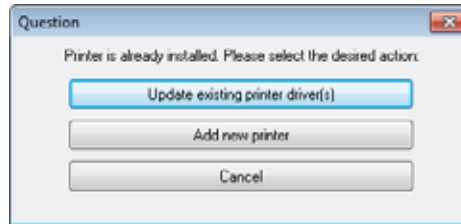
**12. Click Add new printer.**

You are prompted for a printer name, the port to which the printer will be connected, and the language for the printer display.

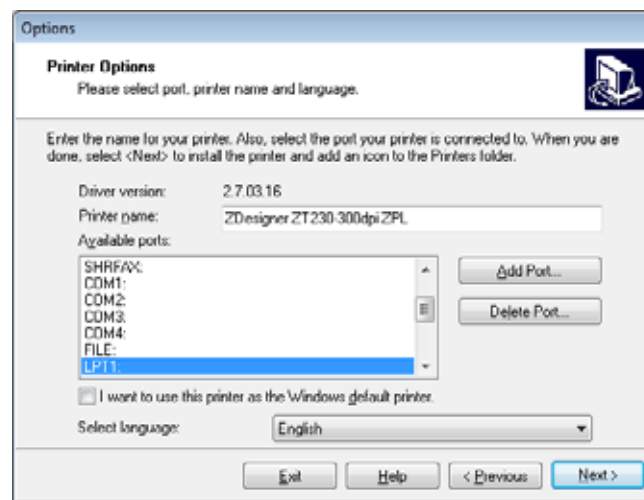
**13. Click Add Port.**

The wizard prompts you for a name for the port and the IP address of your printer.

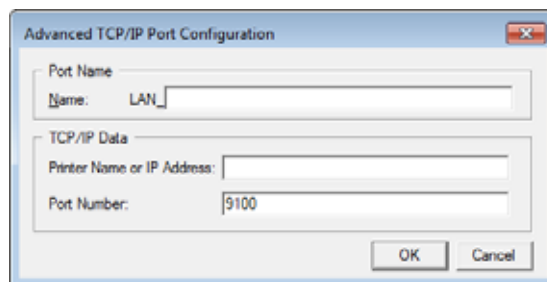

Note • If you have other applications open, you may be prompted that the driver is locked by another process. You may click Next to continue or Exit to allow you to save your work before continuing with this installation.

54 | Printer Setup and Operation

Install the Printer Driver and Connect the Printer to the Computer—Ethernet

14. Give the port a name that you can recognize when it appears in the list of available ports.

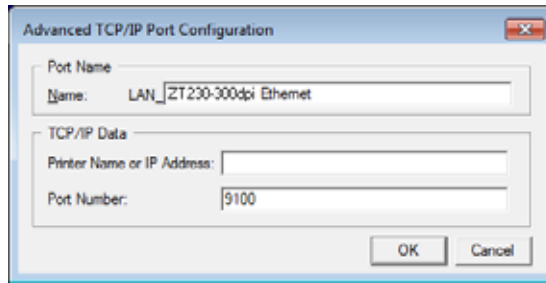

15. Enter the printer's IP address. This could be one that was assigned automatically or one that you specified manually in the previous section.
16. Click OK.

A printer driver is created with the port name that you assigned. The new printer port appears in the list of available ports.

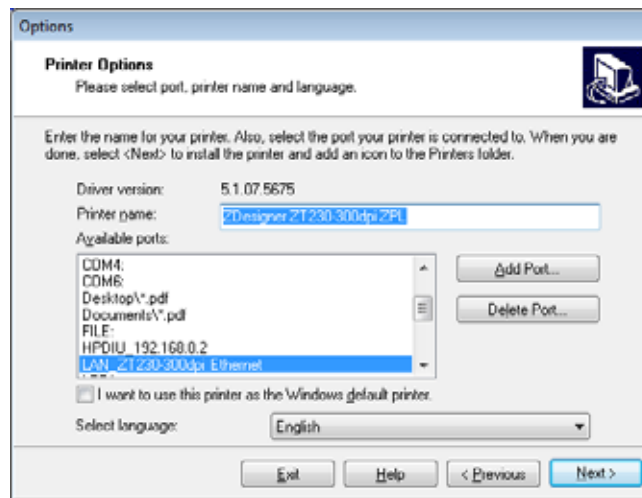

17. Click Next.

You are prompted to launch other setup wizards.

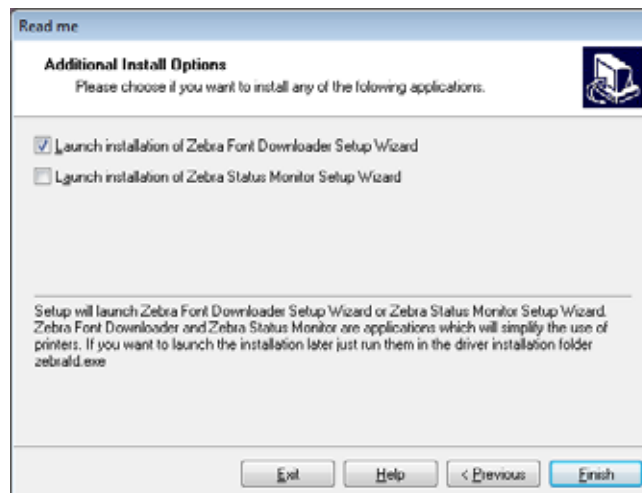

18. Check the desired options, and then click Finish.

The printer driver is installed. If you are prompted that other programs might be affected, click the appropriate option to continue.

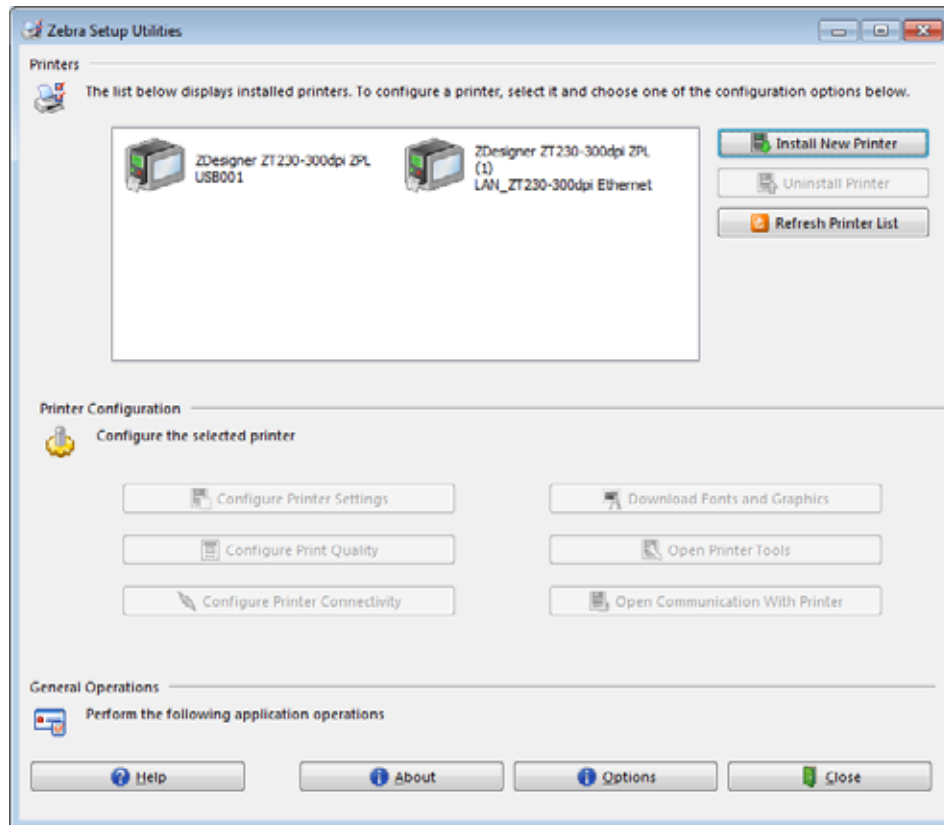

The installation for wired (Ethernet) connections is complete.

Connect the Printer to Your Wireless Network

If you wish to use the printer's optional wireless print server, you must first connect the printer to your computer using one of the other available connections. While the printer is connected via one of those connections, you configure the printer to communicate with your Wireless Local Area Network (WLAN) through the wireless print server.

For additional information about Zebra print servers, refer to the *ZebraNet Wired and Wireless Print Server User Guide*. To download the latest version of this guide, go to <http://www.zebra.com/zt400-info>.



To connect the printer to your computer by an optional wireless print server, complete these steps:

1. Install Zebra Setup Utilities as instructed in *Install Zebra Setup Utilities on page 28*.
2. Connect the printer to your computer using a USB, serial, or optional parallel port as instructed in *Connect a Computer to the Printer's USB Port on page 37* or *Connect a Computer to the Printer's Serial or Parallel Port on page 41*.
3. Configure the following printer settings. You can change the values through the Zebra Setup Utilities (click Configure Printer Connectivity on the Zebra Setup Utilities screen) or by the ways listed at the following links. Contact your network administrator for the proper values for your network.
 - *IP Protocol on page 111* (change the value from ALL to PERMANENT)
 - *Gateway on page 110* (match the gateway value of your WLAN)
 - *Subnet Mask on page 109* (match the subnet value of your WLAN)
 - *IP Address on page 109* (assign a unique IP address to the printer)

Adding a Printer from the Zebra Setup Utilities Screen

4. If necessary, open the Zebra Setup Utilities program.
The Zebra Setup Utilities screen displays.

Figure 14 • Zebra Setup Utilities Screen



5. Click Install New Printer.
The printer driver wizard displays.

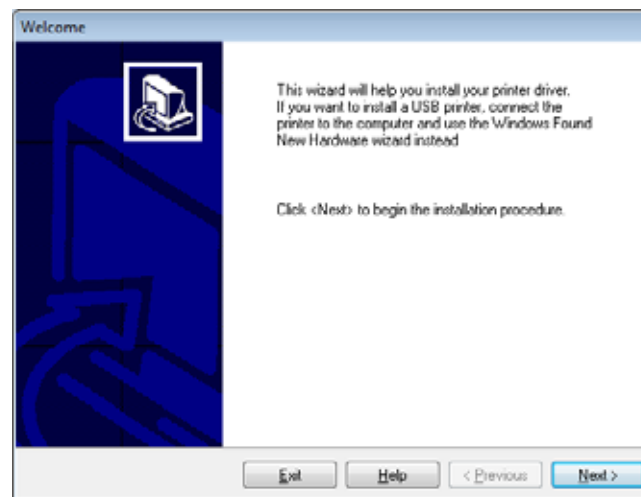

6. Click Next.

You are prompted to select an installation option.

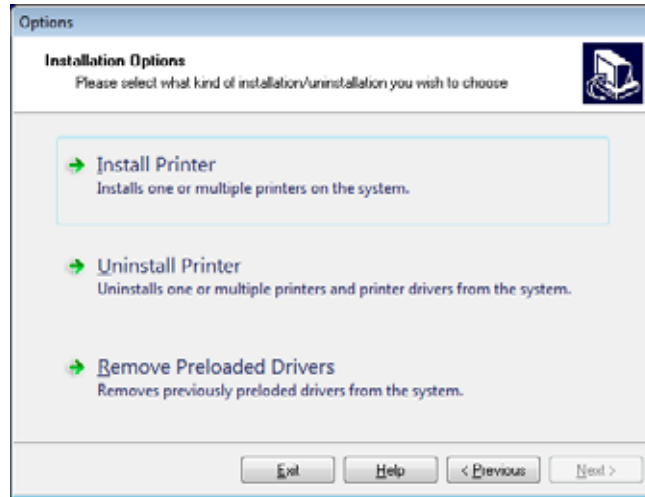

7. Click Install Printer.

You are prompted to select a printer type.

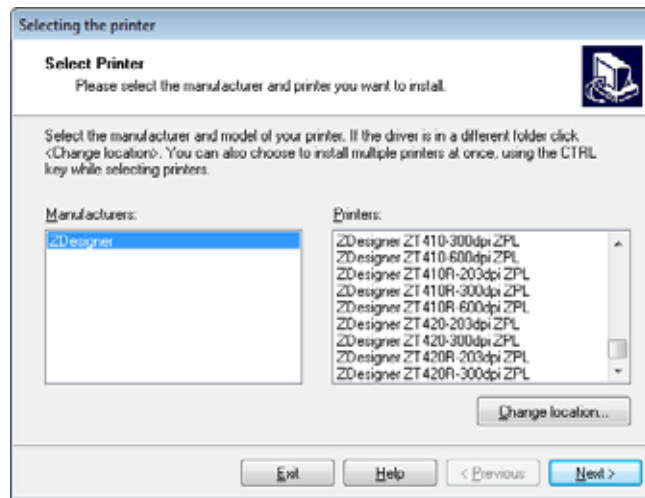

8. Select your printer model and resolution.

The model and resolution are on a part number sticker on the printer, usually located below the media hanger. The information will be in the following format:

Part Number: **XXXXX***Y* – xxxxxxxx

where

XXXXX = the printer model

Y = the printer resolution (2 = 203 dpi, 3 = 300 dpi, 6 = 600 dpi)

For example, in the part number **ZT230x3** – xxxxxxxx

ZT230 indicates that the printer is a ZT230 model

3 indicates that the printhead resolution is 300 dpi

9. Click Next.

You are notified that the printer is already installed.

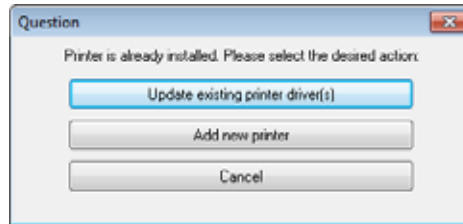

10. Click Add new printer.

You are prompted for a printer name, the port to which the printer will be connected, and the language for the printer display.



11. Click Add Port.

The wizard prompts you for a name for the port and the IP address of your printer.

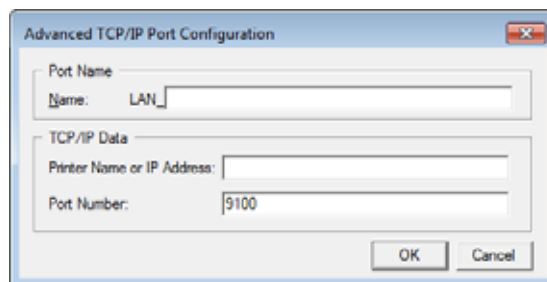

Note • If you have other applications open, you may be prompted that the driver is locked by another process. You may click Next to continue or Exit to allow you to save your work before continuing with this installation.

12. Give the port a name that you can recognize when it appears in the list of available ports.

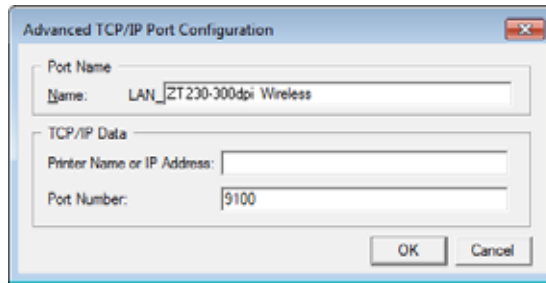

13. Enter the printer's IP address. This could be one that was assigned automatically or one that you specified manually in the previous section.

14. Click OK.

A printer driver is created with the port name that you assigned. The new printer port appears in the list of available ports.

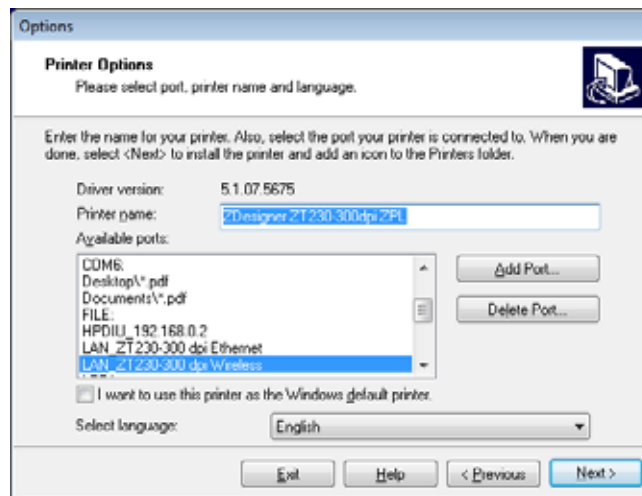

15. Click Next.

You are prompted to launch other setup wizards.

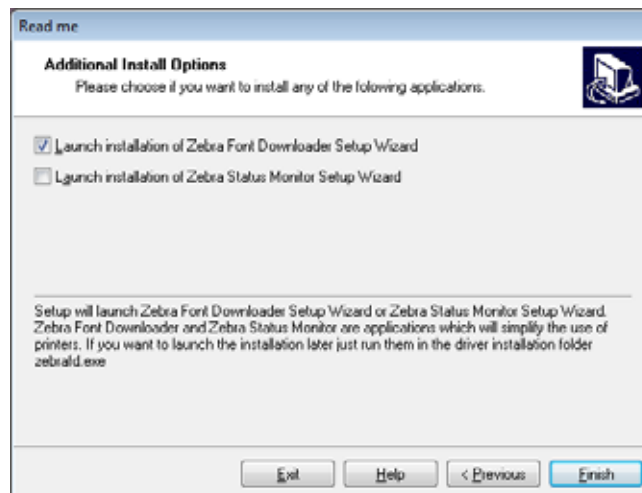

16. Check the desired options, and then click Finish.

The printer driver is installed. If you are prompted that other programs might be affected, click the appropriate option to continue.

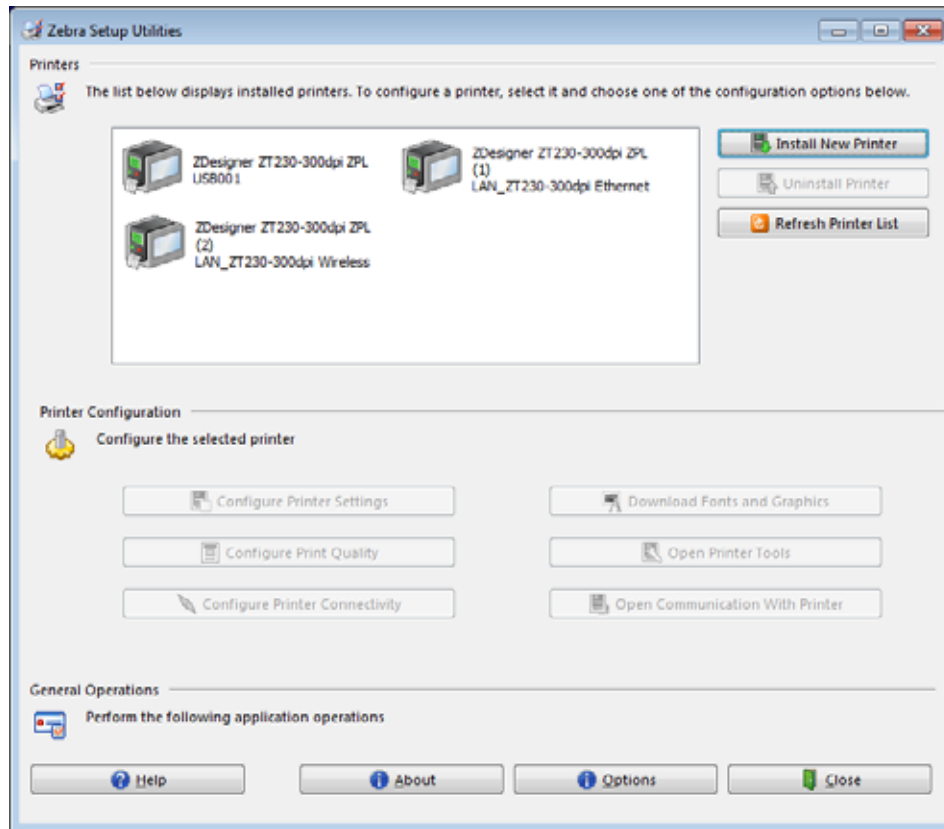

The installation for wireless communication is complete.

Select a Print Mode

Use a print mode that matches the media being used and the printer options available (Table 4).

Table 4 • Print Modes and Printer Options

Print Mode	When to Use/Printer Options Required	Printer Actions
Tear-Off (default setting)	Use for most applications. This mode can be used with any printer options and most media types.	The printer prints label formats as it receives them. The printer operator can tear off the printed labels any time after they print.
<p style="text-align: center;">Roll media in Tear-Off mode (shown using thermal transfer media with ribbon loaded)</p>  <p style="text-align: center;">Fanfold media in Tear-Off mode (shown using direct thermal media and no ribbon)</p> 		

Table 4 • Print Modes and Printer Options

Print Mode	When to Use/Printer Options Required	Printer Actions
Peel-Off	<p>Use if the printer has the Peel-Off option or the Liner Take-Up option.*</p> <p>* The Liner Take-Up option is available only on the ZT230 printer.</p>	<p>The printer peels the label from the liner during printing and then pauses until the label is removed. The liner exits the front of the printer.</p> <ul style="list-style-type: none"> • In Peel-Off mode, the liner exits the front of the printer. • In Peel-Off mode with Liner Take-Up, the liner winds onto the liner take-up spindle or the rewind spindle.
<p>Peel-Off mode (shown without a ribbon system)</p>  <p>Peel-Off mode with Liner Take-Up* (shown using direct thermal media and no ribbon)</p> 		

Table 4 • Print Modes and Printer Options

Print Mode	When to Use/Printer Options Required	Printer Actions
Cutter	Use if the printer has a cutter option when you want the labels to be cut apart.	The printer prints a label and then cuts it free. <p style="text-align: center;">Cutter mode (shown using direct thermal media and no ribbon)</p> 

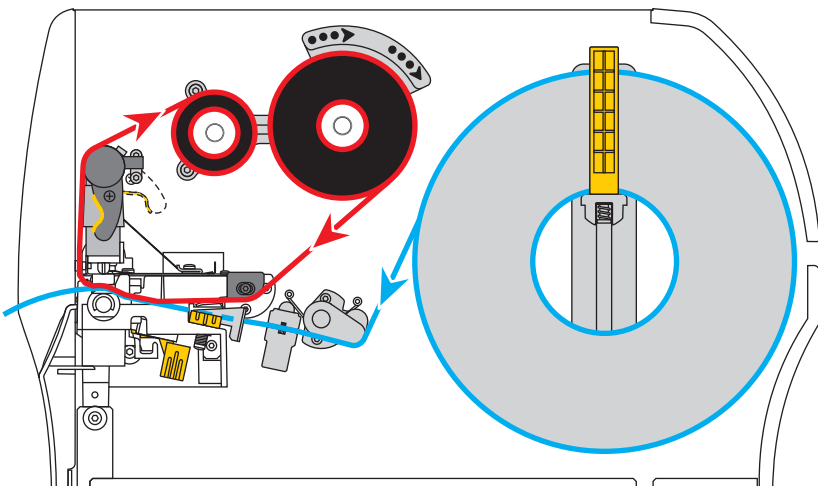
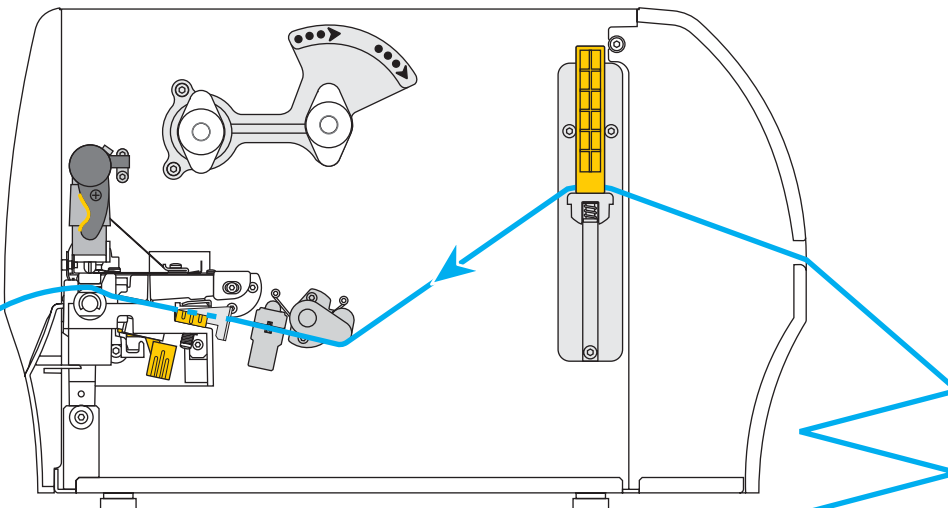
Load the Ribbon

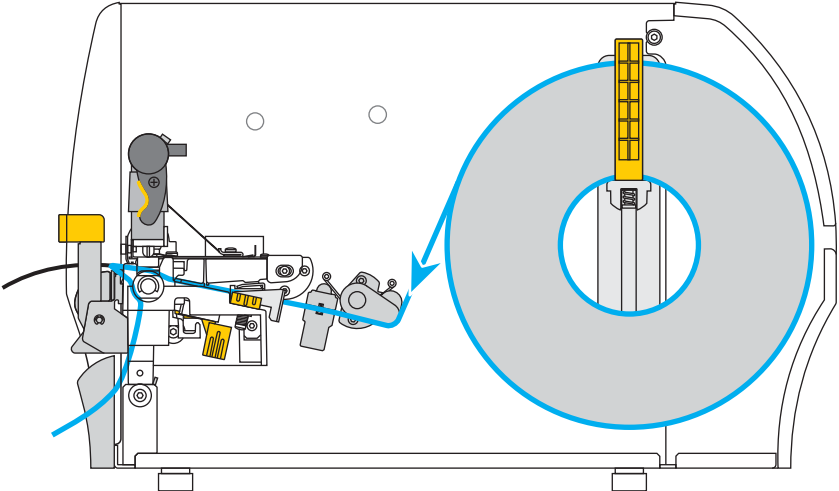
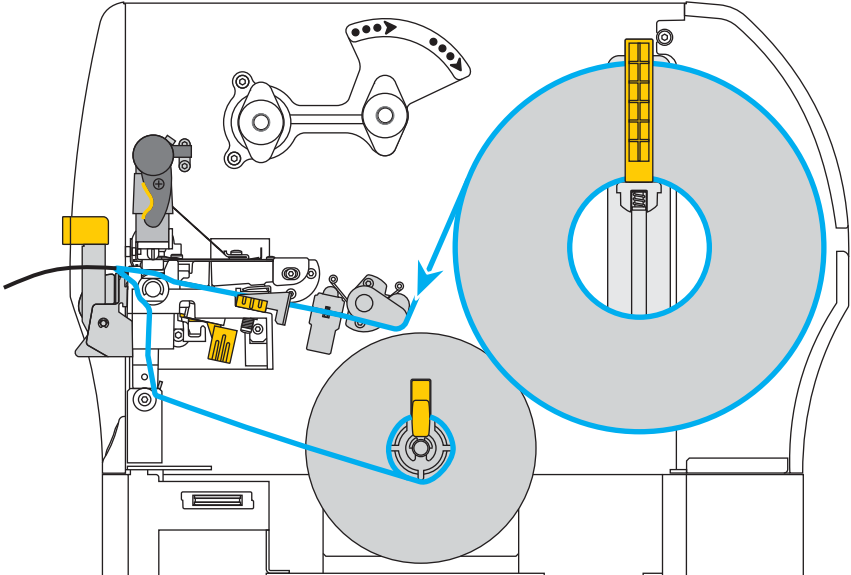
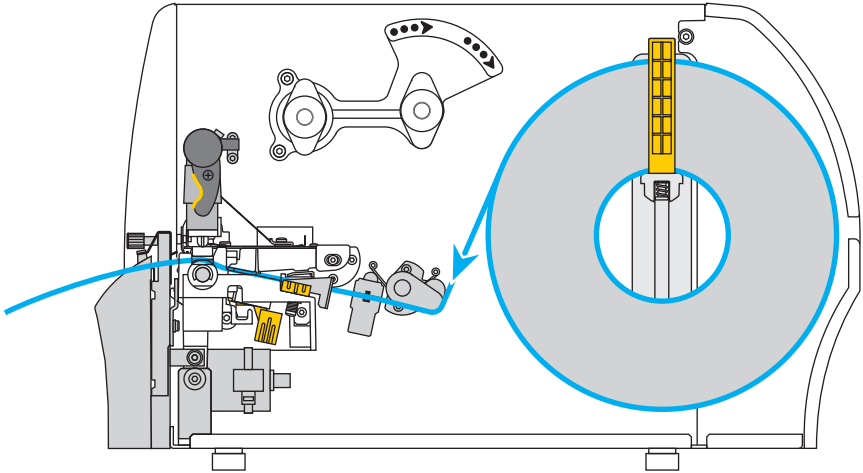

Note • This section applies only to printers that have the Thermal Transfer option installed.

Ribbon is used only with thermal transfer labels. For direct thermal labels, do not load ribbon in the printer. To determine if ribbon must be used with a particular media, see [When to Use Ribbon on page 21](#).

Caution • While performing any tasks near an open printhead, remove all rings, watches, hanging necklaces, identification badges, or other metallic objects that could touch the printhead. You are not required to turn off the printer power when working near an open printhead, but Zebra recommends it as a precaution. If you turn off the power, you will lose all temporary settings, such as label formats, and you must reload them before you resume printing.



Important • Use ribbon that is wider than the media to protect the printhead from wear. Ribbon must be coated on the outside.

To load ribbon, complete these steps:

1. Raise the media door.

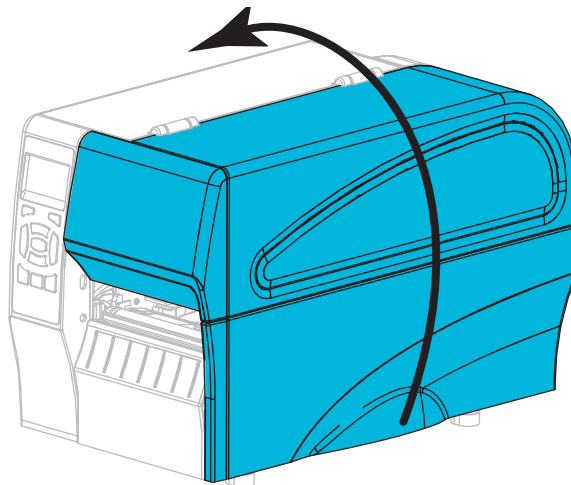



2. **Caution** • The printhead may be hot and could cause severe burns. Allow the printhead to cool.

Open the printhead assembly by rotating the printhead-open lever.

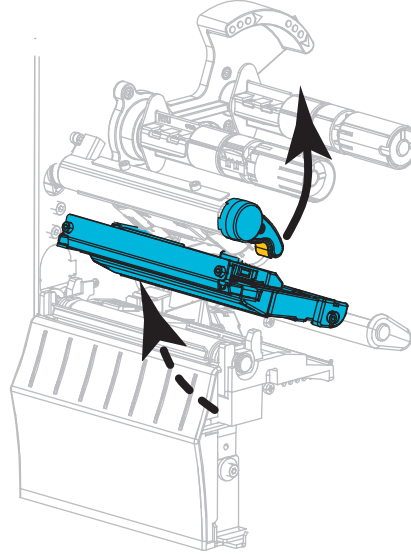

3. Place the roll of ribbon on the ribbon supply spindle with the loose end of the ribbon unrolling as shown. Push the roll back as far as it will go.

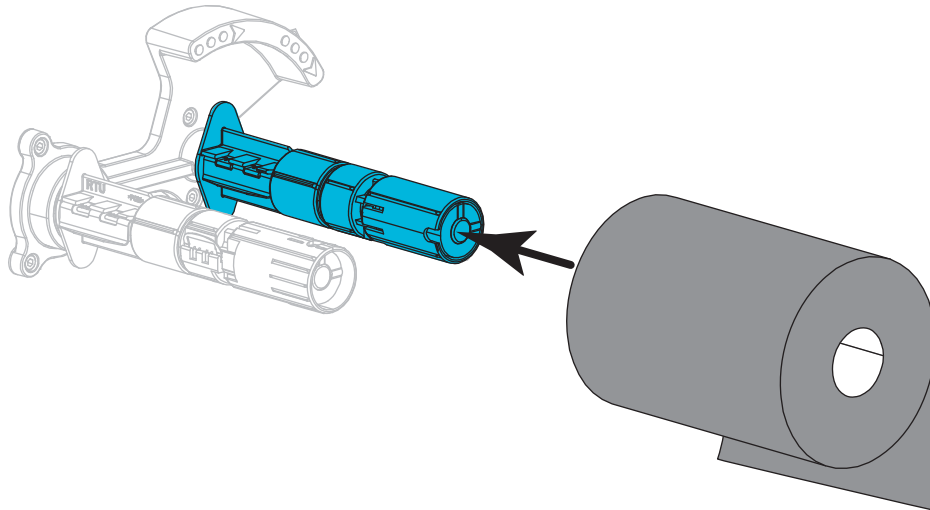

4. Your printer shipped with an empty ribbon core on the ribbon take-up spindle. If this core is no longer there, place an empty ribbon core on the ribbon take-up spindle. Push the core back as far as it will go.

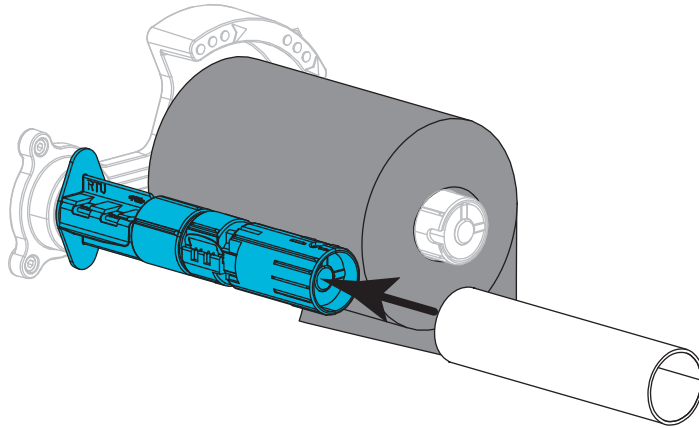

5. Bring the ribbon under the printhead assembly as shown.

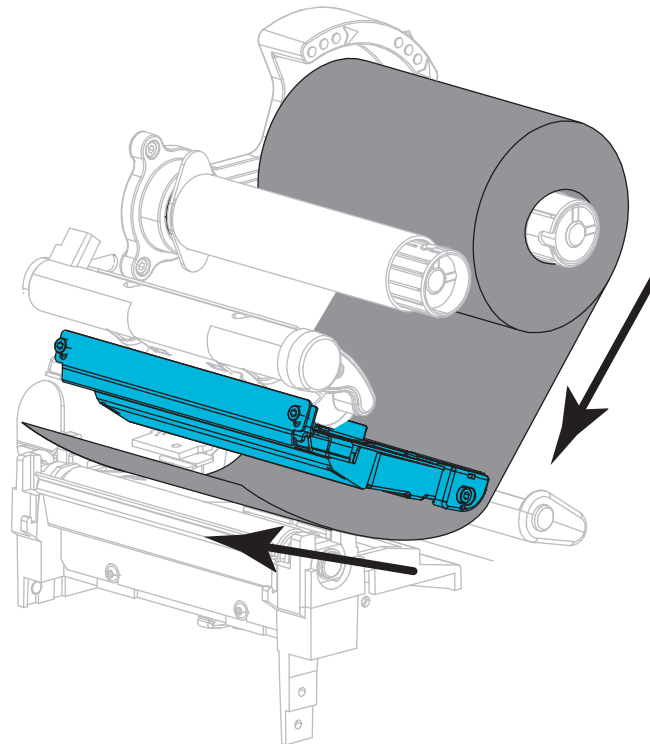

6. With the ribbon tracking as far back as it can under the printhead assembly, wrap the ribbon around the core on the ribbon take-up spindle. Rotate the spindle several turns in the direction shown to tighten and align the ribbon.

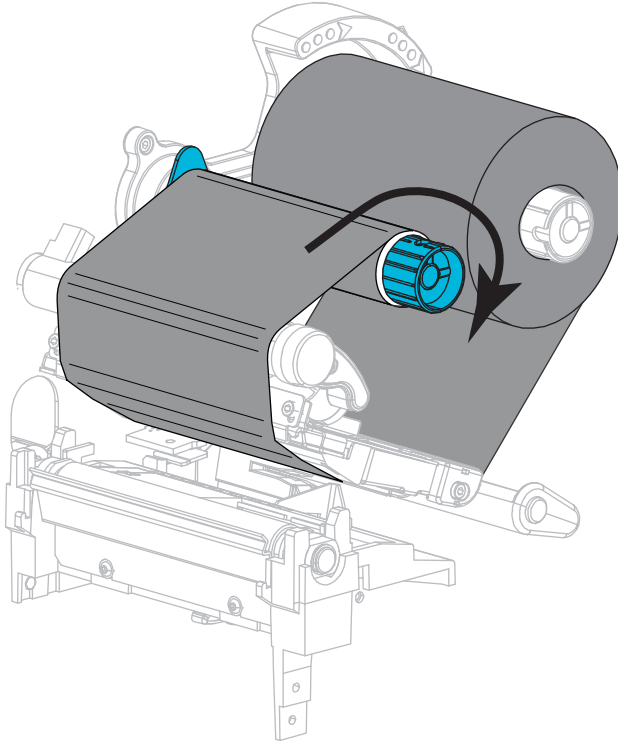

7. If media is already loaded, rotate the printhead-open lever downward until it locks the printhead in place. Otherwise, continue with [Load the Media on page 70](#).

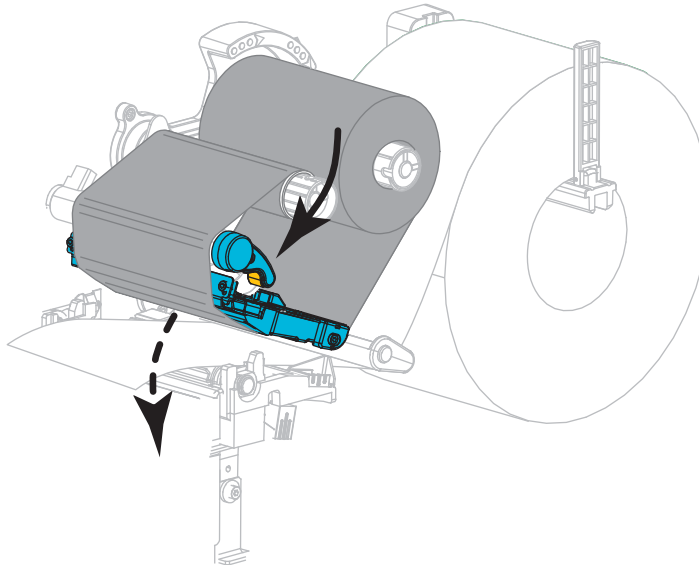

8. Close the media door.

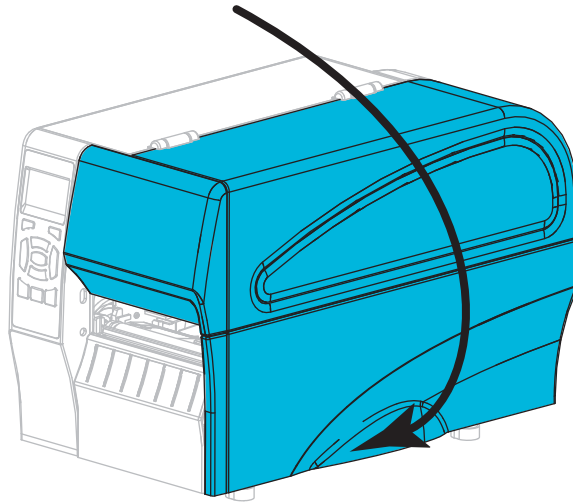

9. If necessary, press **PAUSE** to enable printing.

Load the Media

Use the instructions in this section for loading roll or fanfold media in any print mode.

Caution • While performing any tasks near an open printhead, remove all rings, watches, hanging necklaces, identification badges, or other metallic objects that could touch the printhead. You are not required to turn off the printer power when working near an open printhead, but Zebra recommends it as a precaution. If you turn off the power, you will lose all temporary settings, such as label formats, and you must reload them before you resume printing.

To load media, complete these steps:

1. Raise the media door.

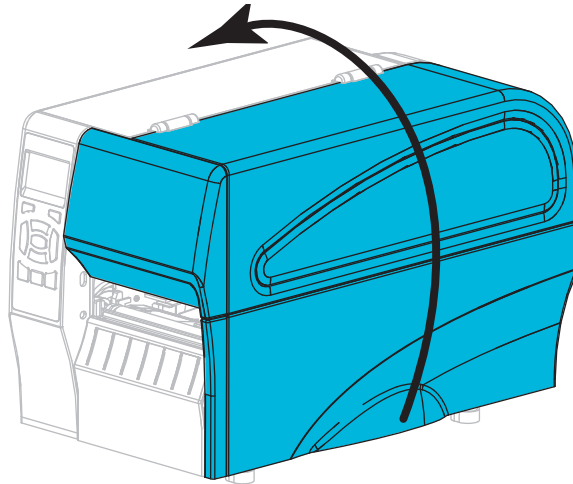

2. **Caution** • The printhead may be hot and could cause severe burns. Allow the printhead to cool.

Open the printhead assembly by rotating the printhead-open lever.

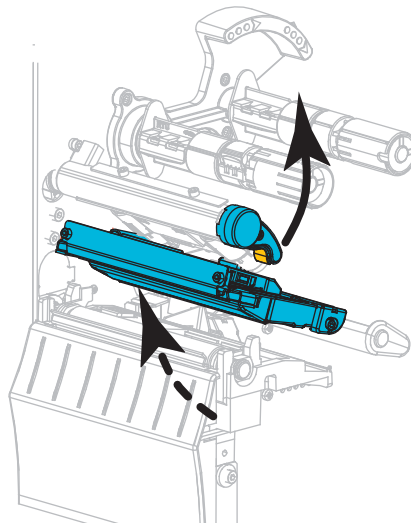

3. Insert media into the printer. Follow the instructions for roll or fanfold media, as appropriate.



Roll Media

- a. Remove and discard any tags or labels that are dirty or that are held by adhesives or tape.

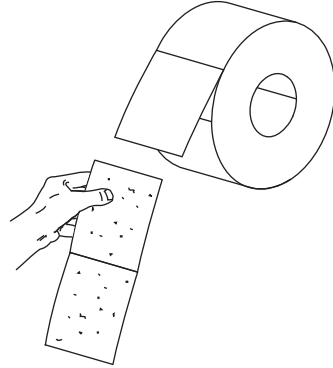

- b. Slide out and flip down the media supply guide.

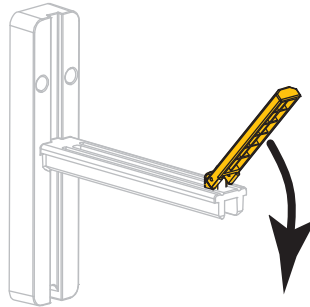

Fanfold Media

- a. Slide out and flip down the media supply guide.

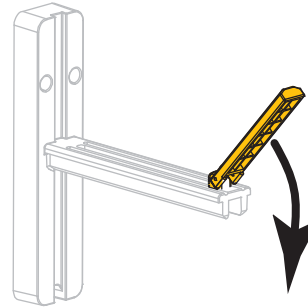

- b. Insert the fanfold media through the rear of the printer.

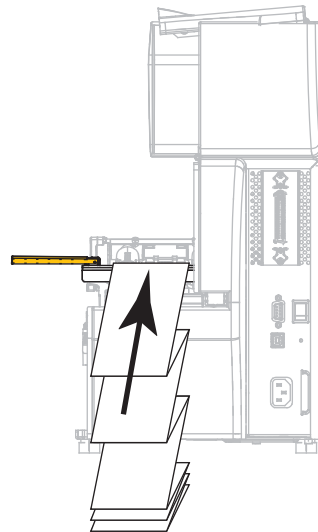



Roll Media (Continued)

- c. Place the roll of media on the media supply hanger. Push the roll back as far as it will go.

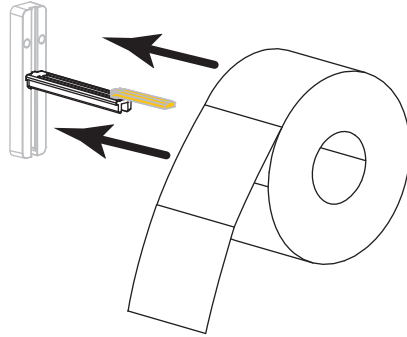

- d. Flip up the media supply guide.

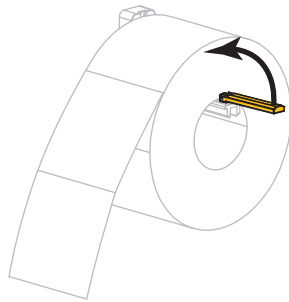

- e. Slide in the media supply guide until it touches the edge of the roll.

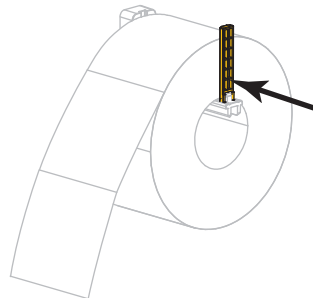

Fanfold Media (Continued)

- c. Drape the media over the media supply hanger.

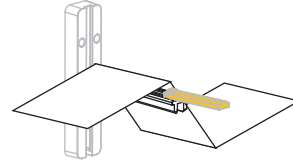

- d. Flip up the media supply guide.

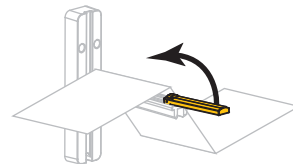

- e. Slide in the media supply guide until it touches the edge of the media.

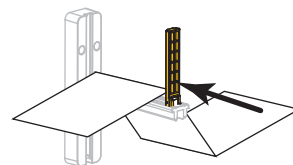

- f. Continue with the remaining steps as shown for roll media.

4. Slide the outer media guide all the way out.

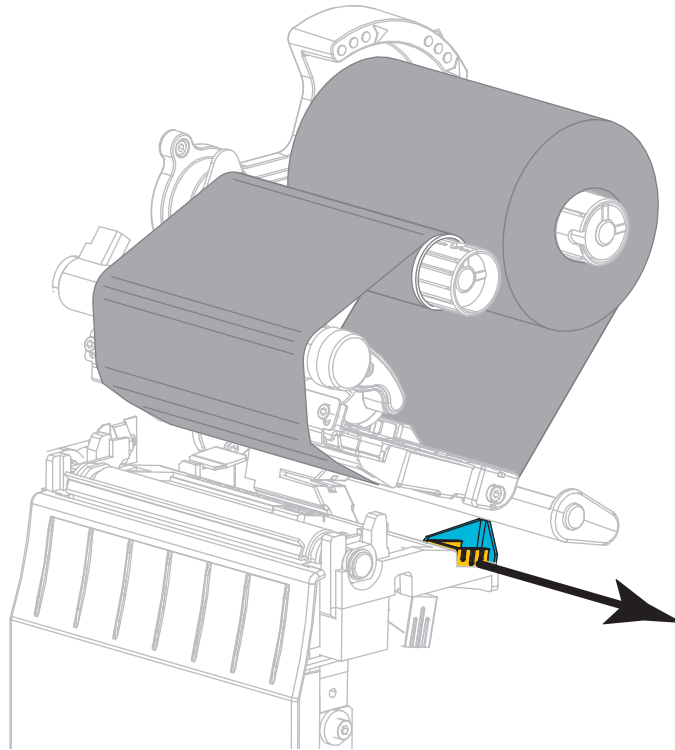

5. Slide the media under the media dancer assembly and the printhead assembly. Allow the end of the media to extend out of the front of the printer.

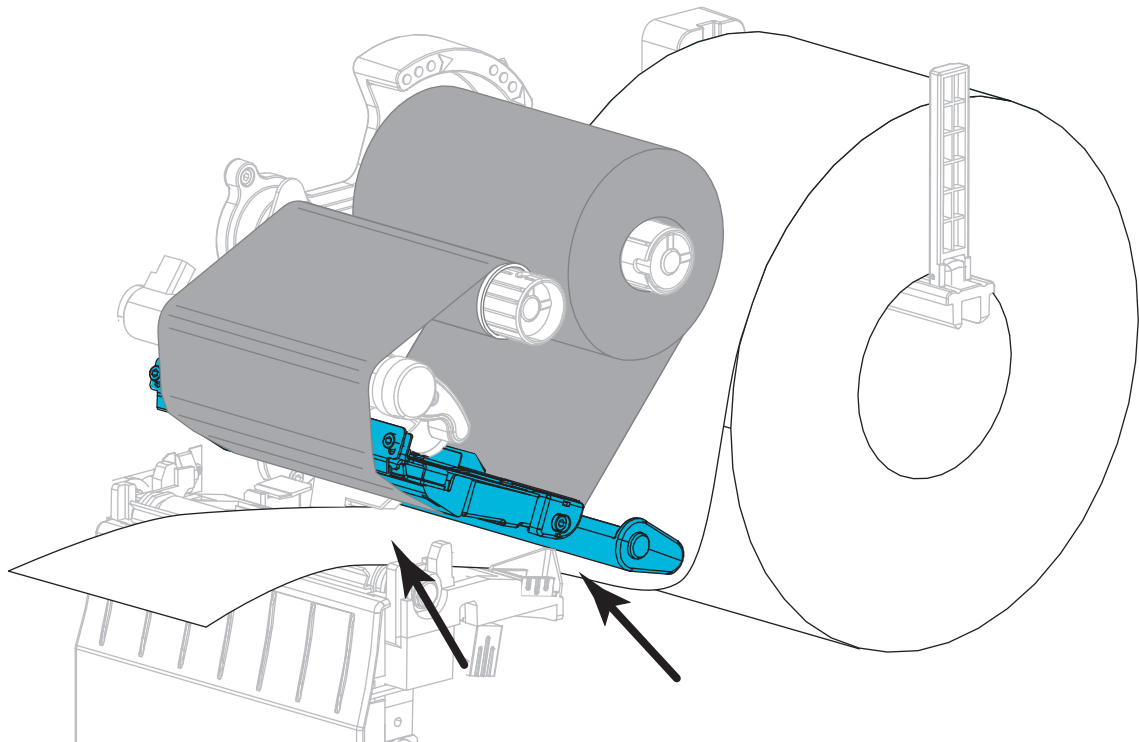

6. Make sure that the media passes through the slot in the transmissive media sensor (1) and under the inner media guide (2). The media should just touch the back of the transmissive media sensor slot.

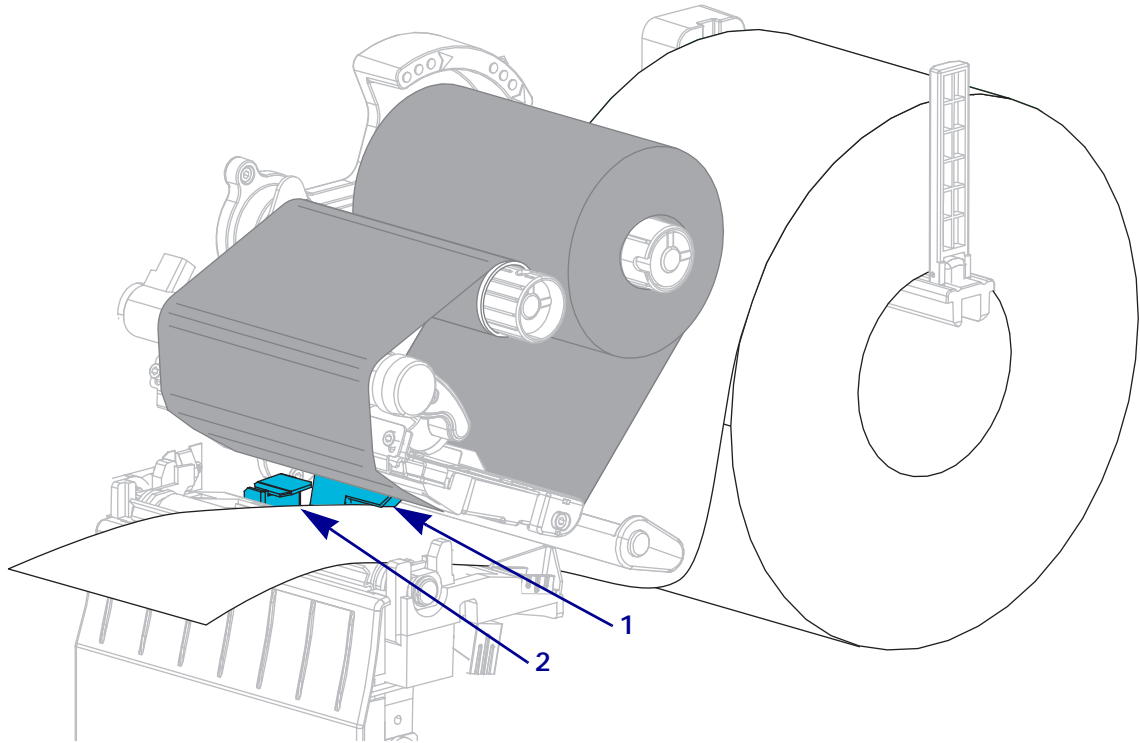

7. In which print mode will your printer be operating? (For more information on print modes, see [Select a Print Mode](#) on page 62.)

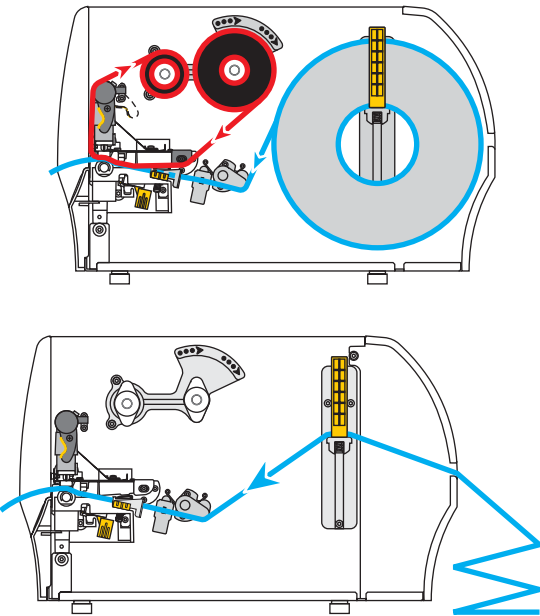
If using...	Then...
<p data-bbox="423 1224 609 1262">Tear-Off mode</p> 	<p data-bbox="998 1224 1339 1291">Continue with <i>Final Steps for Tear-Off Mode</i> on page 76.</p>

If using...

Peel-Off mode (with or without Liner Take-Up)

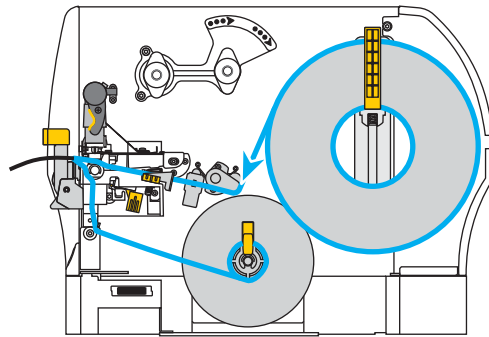
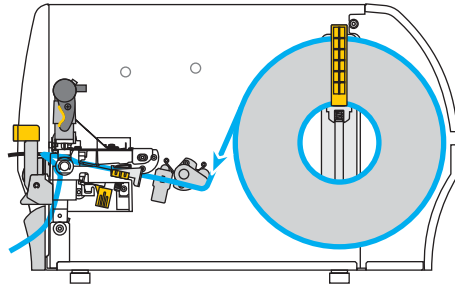

Cutter mode

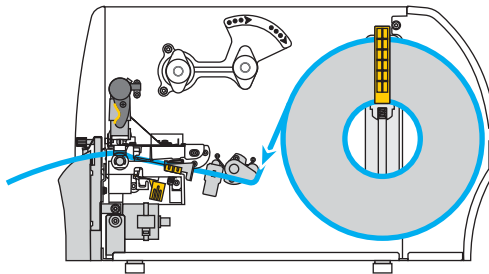

Then...

Continue with *Final Steps for Peel-Off Mode (with or without Liner Take-Up)* on page 78.

Continue with *Final Steps for Cutter Mode* on page 84.

Final Steps for Tear-Off Mode

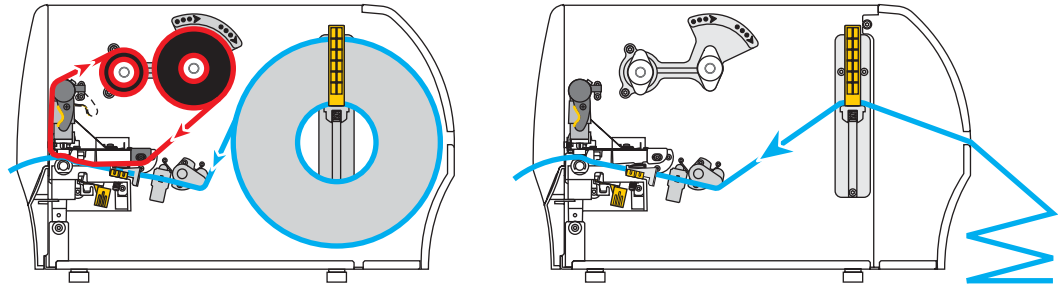

1. Slide in the outer media guide until it just touches the edge of the media.

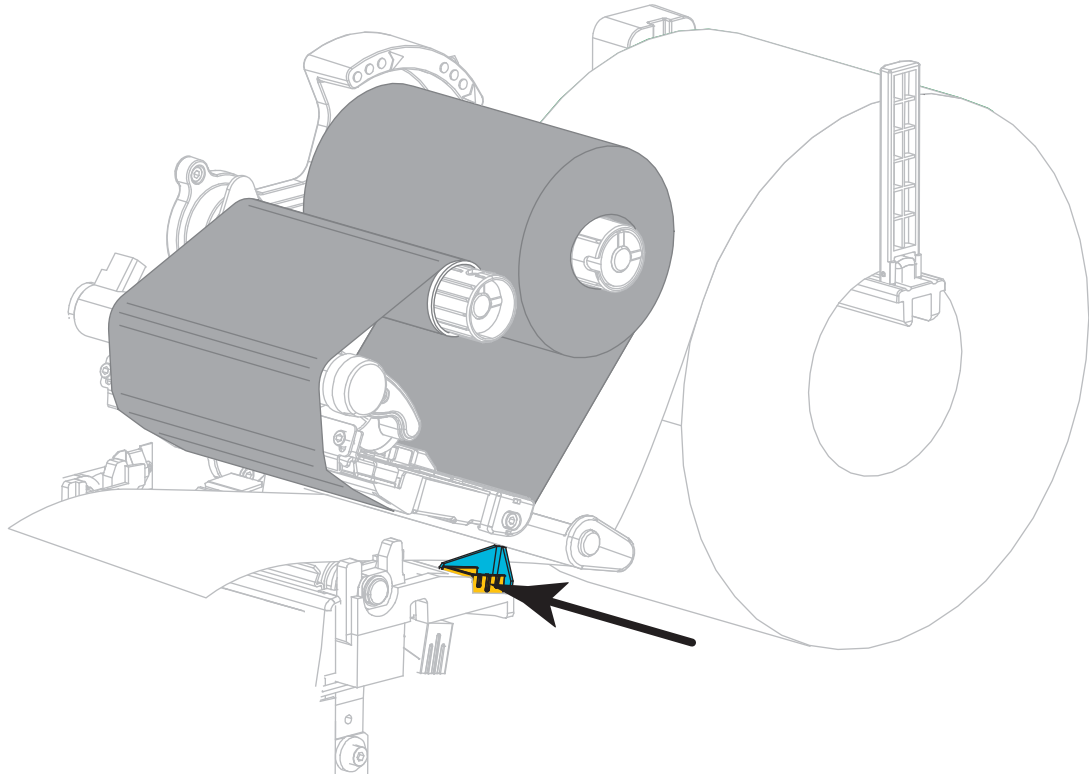

2. Rotate the printhead-open lever downward until it locks the printhead in place.

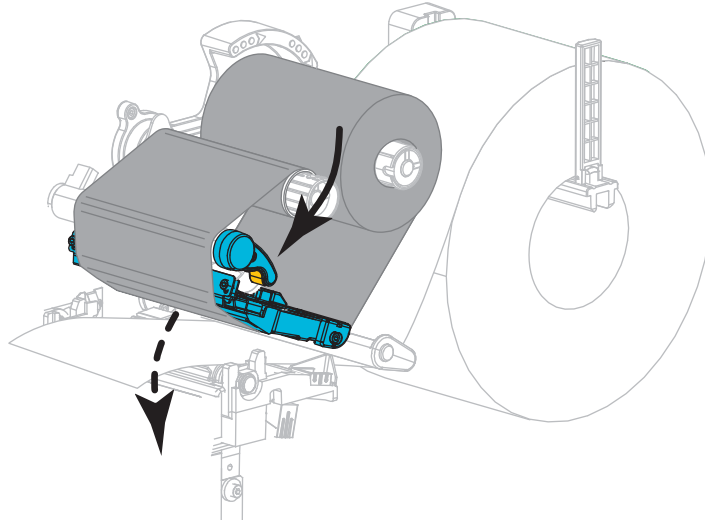

3. Set the printer to Tear-Off mode (for more information, see [Print Mode on page 97](#)).
4. Close the media door.

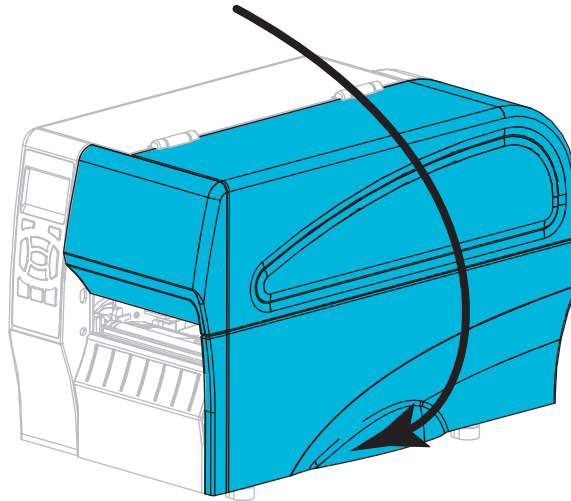

5. Press **PAUSE** to exit pause mode and enable printing.
The printer may perform a label calibration or feed a label, depending on your settings.
6. For best results, calibrate the printer. See [Calibrate the Ribbon and Media Sensors on page 122](#).
7. If desired, perform the [CANCEL Self Test on page 165](#) to verify that your printer is able to print.
Media loading in Tear-Off mode is complete.

Final Steps for Peel-Off Mode (with or without Liner Take-Up)

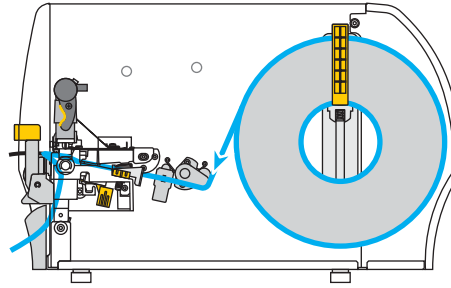

1. Push down the peel-off mechanism release lever to open the peel assembly.

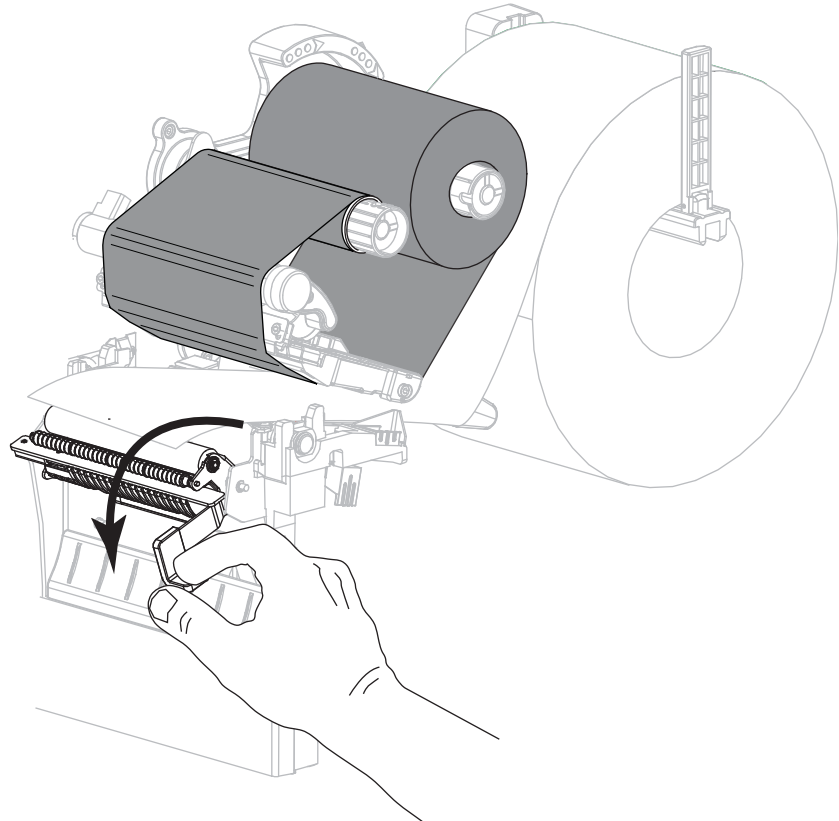

2. Extend the media approximately 18 in. (500 mm) out of the printer.

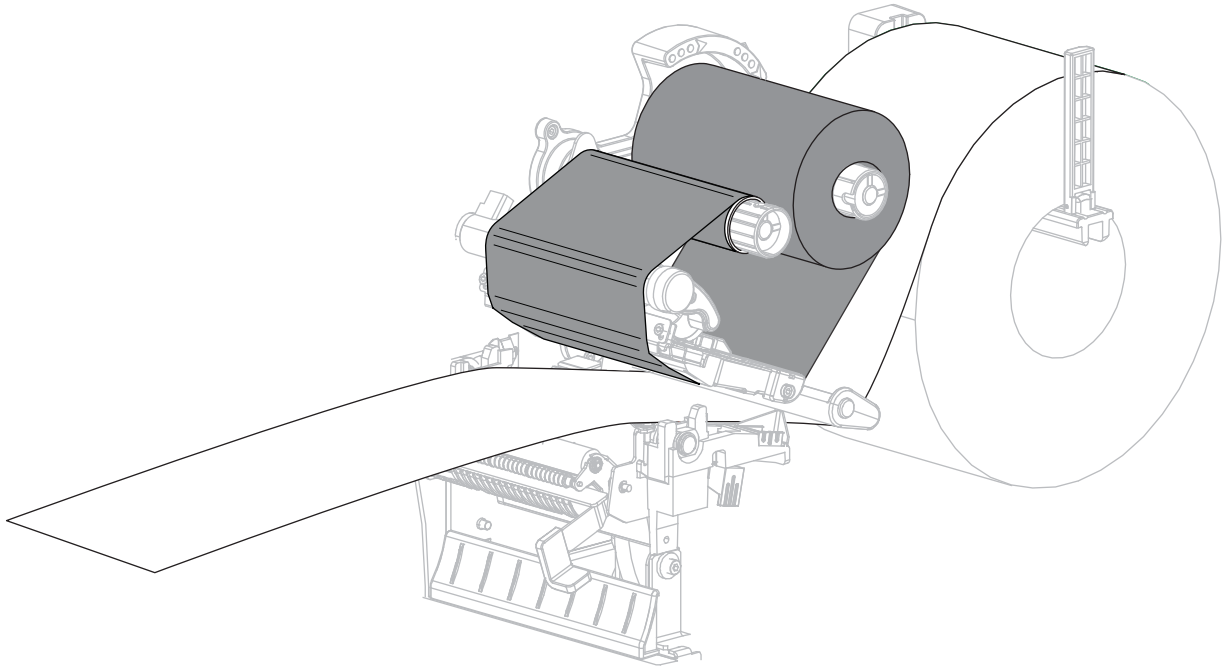

3. Remove the exposed labels so that only the liner remains.

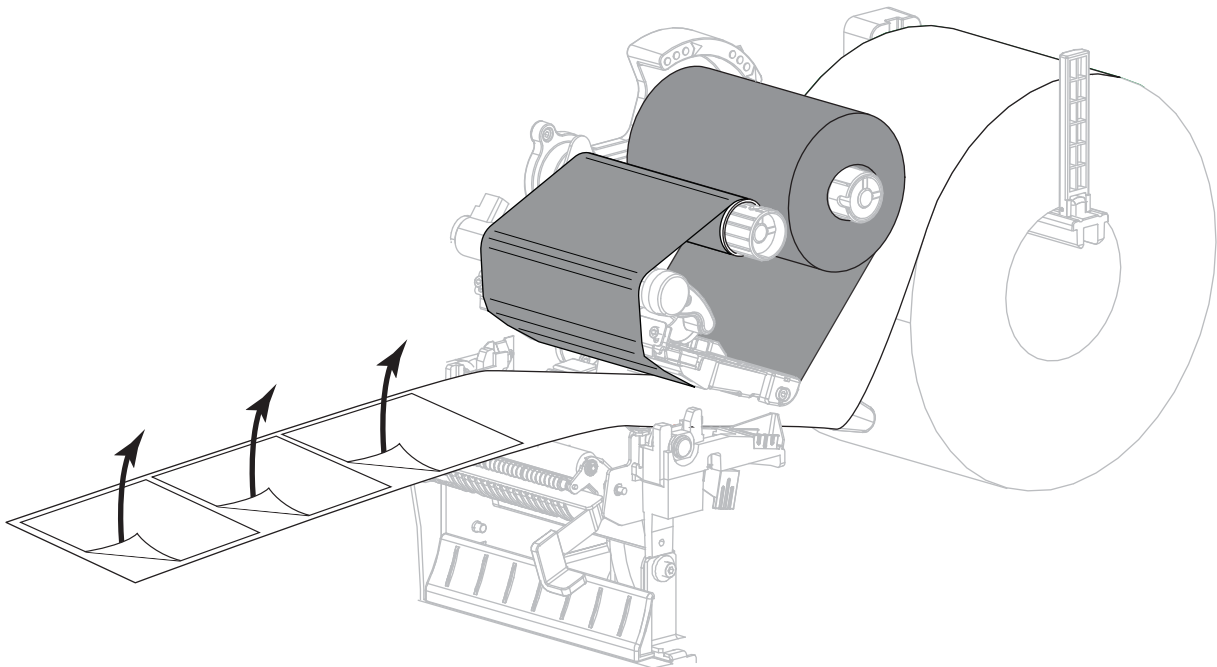

4. Feed the liner behind the peel assembly. Make sure that the end of the liner falls outside of the printer.

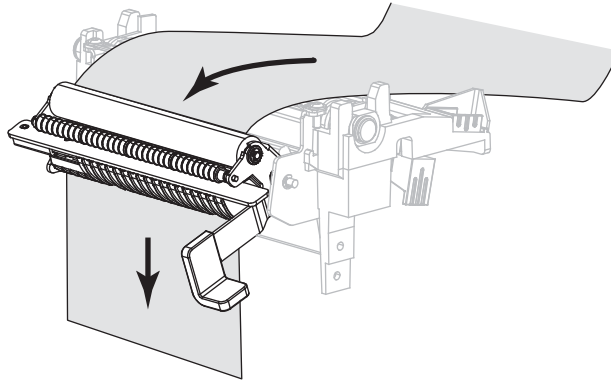

5. Complete this step only if you want to use Peel-Off mode with Liner Take-Up. Your printer must have the Liner Take-Up option installed.

- 5-a. Slide the liner into the slot in the liner take-up spindle (1).

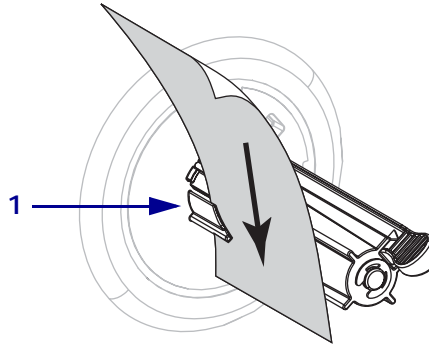

- 5-b. Push the liner back until it touches the back plate of the liner take-up spindle assembly.

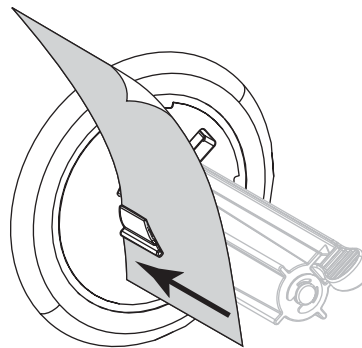

- 5-c. Wrap the liner around the liner take-up spindle and turn the spindle counterclockwise to tighten the liner.

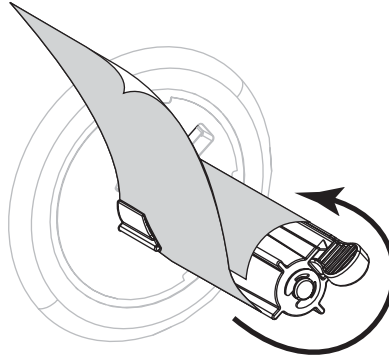

-
6. **Caution** • Use the peel release lever and your right hand to close the peel assembly. Do not use your left hand to assist in closing. The top edge of the peel roller/assembly could pinch your fingers.
-

Close the peel assembly using the peel-off mechanism release lever.

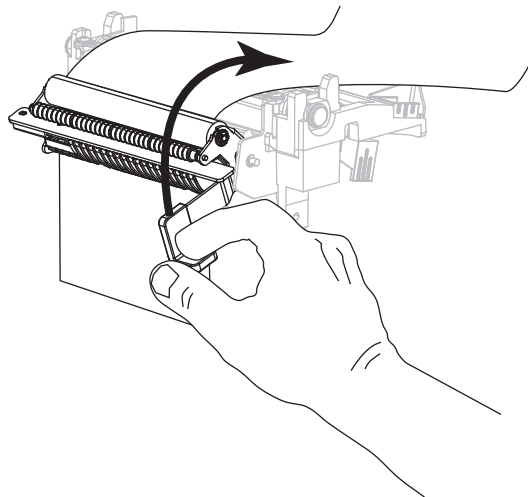

7. Slide in the outer media guide until it just touches the edge of the media.

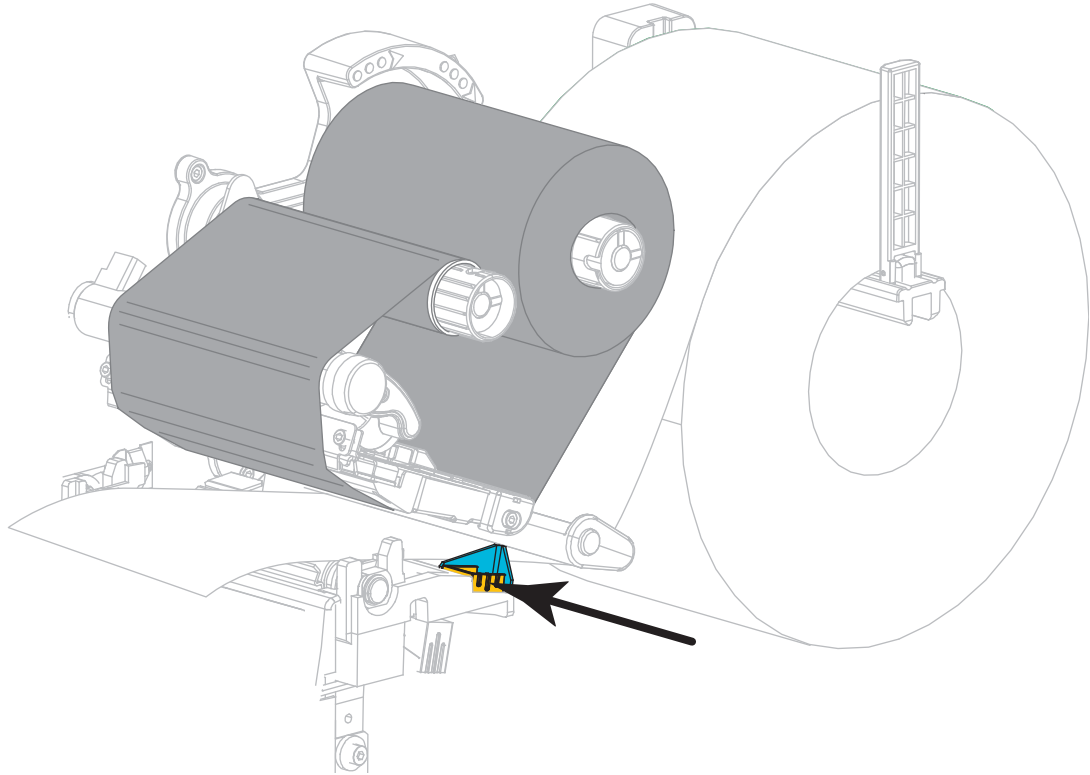

8. Rotate the printhead-open lever downward until it locks the printhead in place.

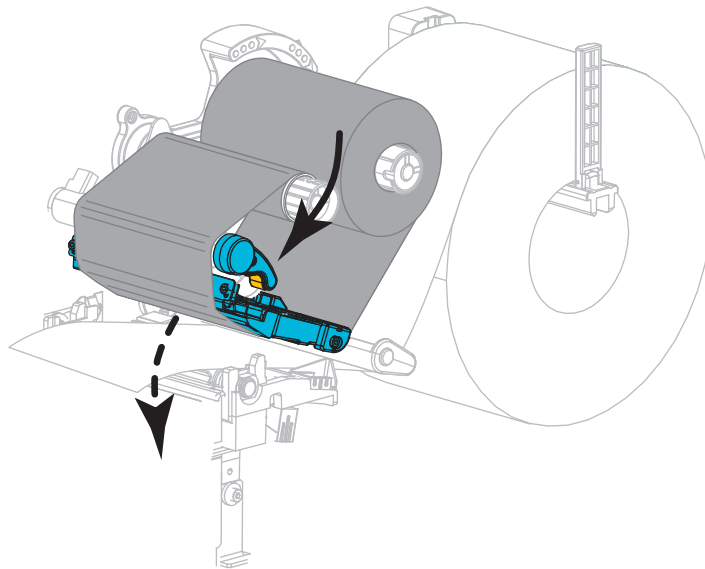

9. Set the printer to Peel-Off mode (for more information, see [Print Mode on page 97](#)).

10. Close the media door.

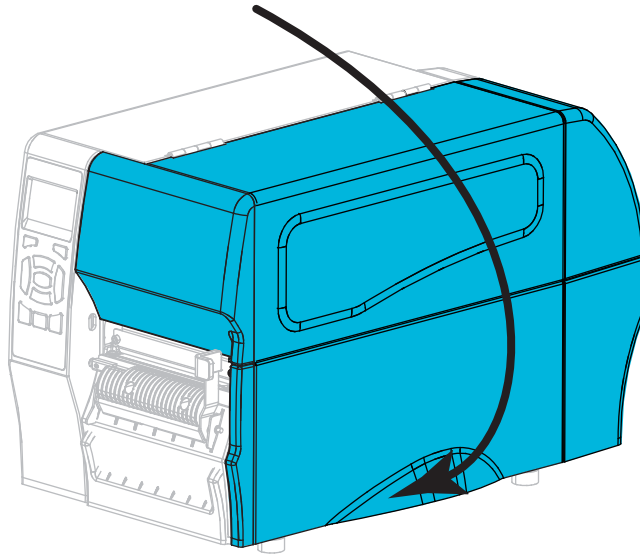

11. Press **PAUSE** to exit pause mode and enable printing.
The printer may perform a label calibration or feed a label, depending on your settings.
12. For best results, calibrate the printer. See [Calibrate the Ribbon and Media Sensors on page 122](#).
13. If desired, perform the [CANCEL Self Test on page 165](#) to verify that your printer is able to print.
Media loading in Peel-Off mode is complete.

Final Steps for Cutter Mode

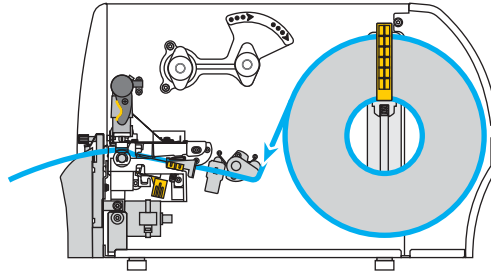

1. **Caution** • The cutter blade is sharp. Do not touch or rub the blade with your fingers.

Feed the media through the cutter.

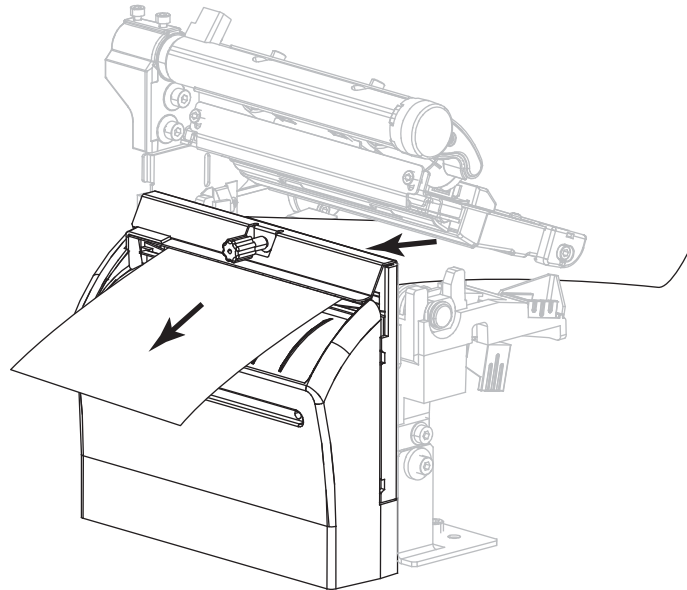

2. Slide in the outer media guide until it just touches the edge of the media.

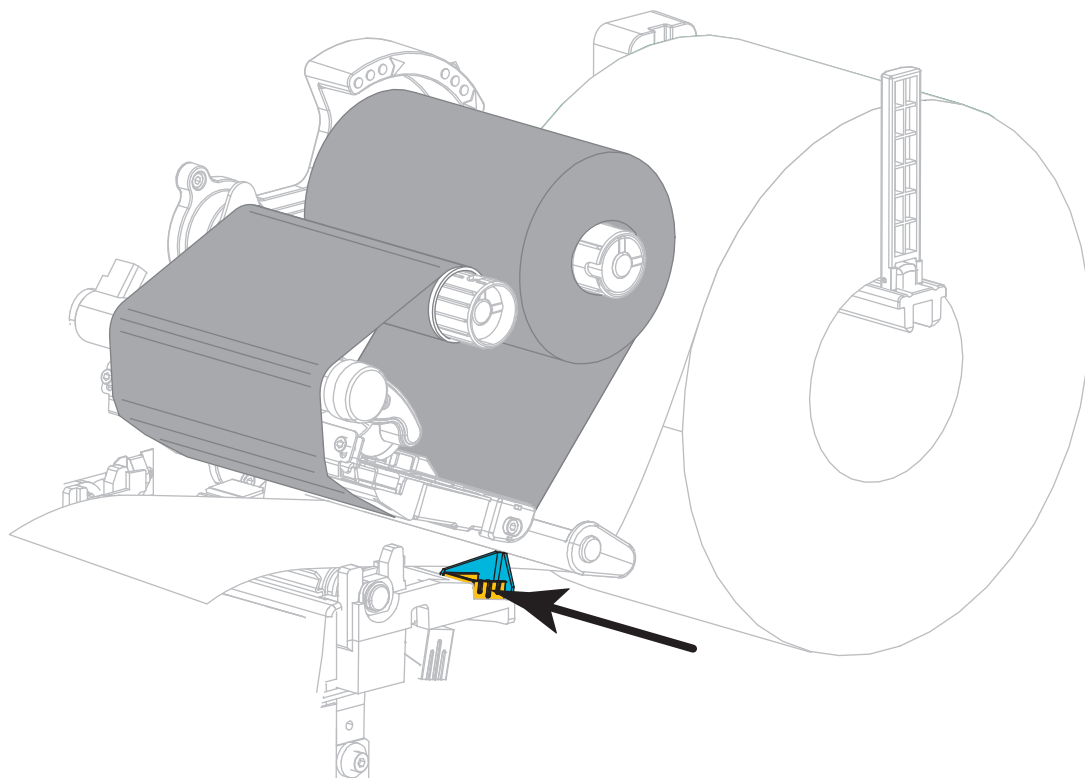

3. Rotate the printhead-open lever downward until it locks the printhead in place.

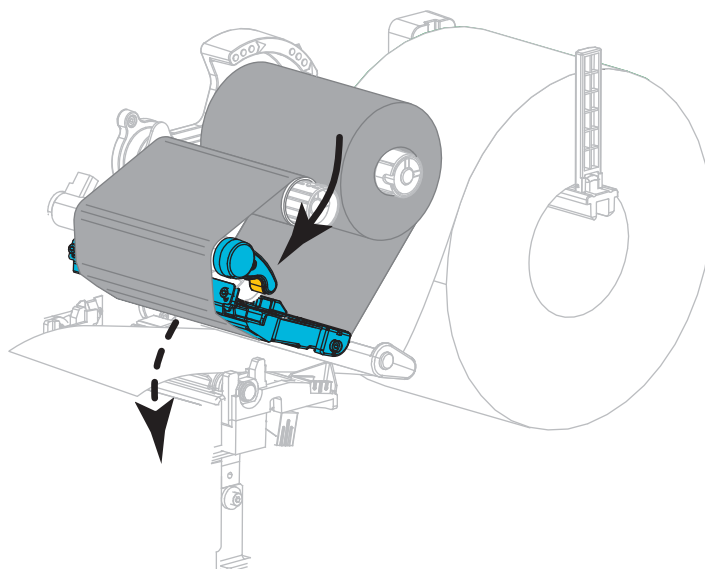

4. Set the printer to Cutter mode (for more information, see [Print Mode on page 97](#)).

5. Close the media door.

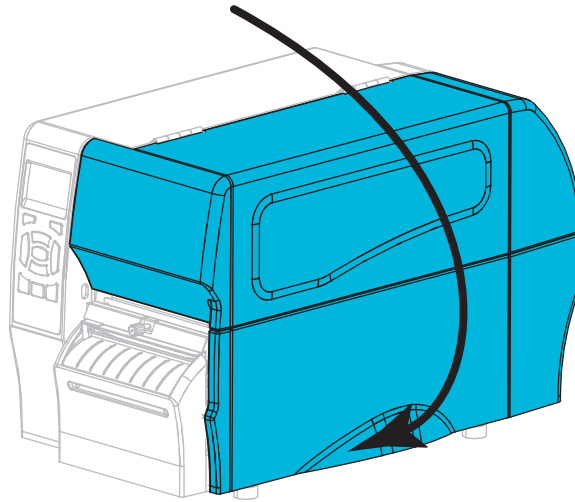

6. Press **PAUSE** to exit pause mode and enable printing.
The printer may perform a label calibration or feed a label, depending on your settings.
7. For best results, calibrate the printer. See [Calibrate the Ribbon and Media Sensors on page 122](#).
8. If desired, perform the [CANCEL Self Test on page 165](#) to verify that your printer is able to print.
Media loading in Cutter mode is complete.

Print a Test Label and Make Adjustments

After you have loaded media, loaded ribbon (if using Thermal Transfer mode), installed the printer driver, and connected your printer to your computer, use the directions in this section to print a test label. Printing this label allows you to see if your connection is working and if you need to adjust any of the printer settings.

To print a test label and adjust the printer (if necessary), complete these steps:

1. Open the Zebra Setup Utilities to return to the Zebra Setup Utilities screen.

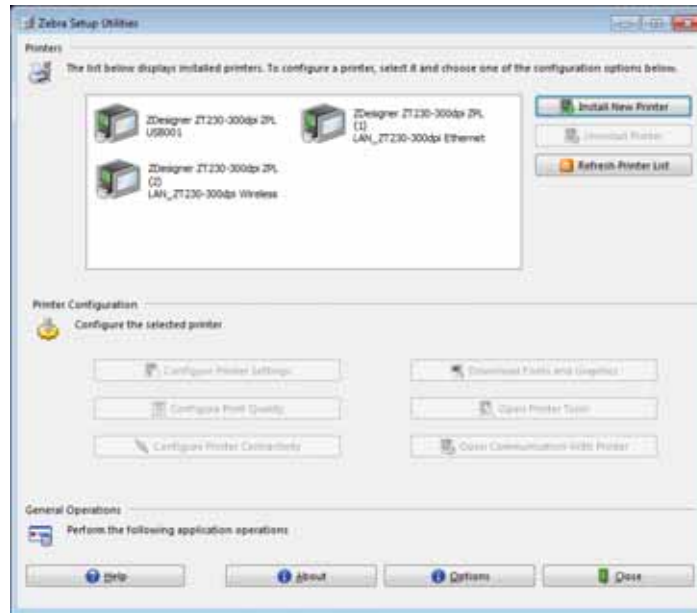

2. Click on one of the available print drivers for your printer.

3. Click Open Printer Tools.

The Tools window displays the available printer commands.

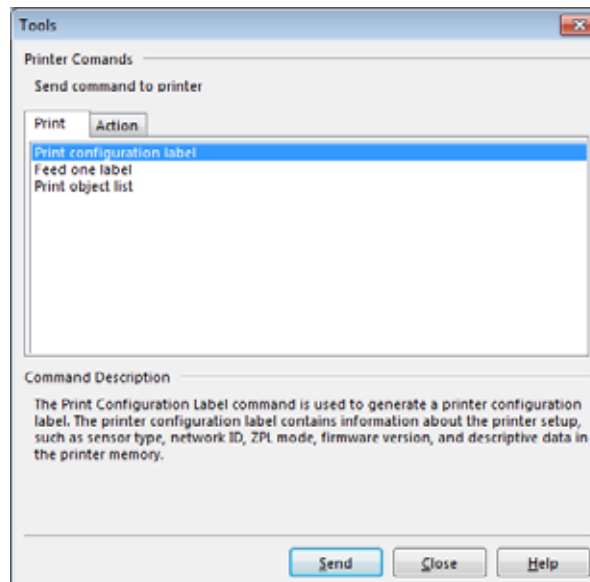

- Click Send to print a printer configuration label.
- If your connection is working correctly and your printer is correctly loaded with media and ribbon (if used), a printer configuration label prints.

Figure 15 • Sample Printer Configuration Label

PRINTER CONFIGURATION	
Zebra Technologies	
ZTC ZT230-203dpi ZPL	
XXXXXX-XX-XXXX	
10.....	LCD CONTRAST
+10.....	DARKNESS
2.0 IPS.....	PRINT SPEED
+000.....	TEAR OFF
TEAR OFF.....	PRINT MODE
GAP/NOTCH.....	MEDIA TYPE
REFLECTIVE.....	SENSOR SELECT
832.....	PRINT WIDTH
1422.....	LABEL LENGTH
.....	PRINT HEAD ID
39.0IN 988MM.....	MAXIMUM LENGTH
NOT CONNECTED.....	USB COMM.
BIDIRECTIONAL.....	PARALLEL COMM.
RS232.....	SERIAL COMM.
2400.....	BAUD
8 BITS.....	DATA BITS
NONE.....	PARITY
XON/XOFF.....	HOST HANDSHAKE
NONE.....	PROTOCOL
NORMAL MODE.....	COMMUNICATIONS
<*> 7EH.....	CONTROL PREFIX
<^> 5EH.....	FORMAT PREFIX
<.> 2CH.....	DELIMITER CHAR
ZPL II.....	ZPL MODE
CALIBRATION.....	MEDIA POWER UP
CALIBRATION.....	HEAD CLOSE
DEFAULT.....	BACKFEED
+000.....	LABEL TOP
+0000.....	LEFT POSITION
DISABLED.....	REPRINT MODE
020.....	WEB SENSOR
024.....	MEDIA SENSOR
255.....	TAKE LABEL
027.....	MARK SENSOR
027.....	MARK MED SENSOR
102.....	TRANS GAIN
000.....	TRANS BASE
100.....	TRANS LED
050.....	MARK LED
DPCSWFXM.....	MODES ENABLED
.....	MODES DISABLED
832 8/MM FULL.....	RESOLUTION
V72.18.1ZP1510? <-.....	FIRMWARE
1.3.....	XML SCHEMA
6.4.1 255.....	HARDWARE ID
NONE.....	OPTION BOARD
12288k.....R:	RAM
65536k.....E:	ONBOARD FLASH
NONE.....	FORMAT CONVERT
FW VERSION.....	IDLE DISPLAY
07/20/12.....	RTC DATE
02:37.....	RTC TIME
DISABLED.....	ZBI
2.1.....	ZBI VERSION
READY.....	ZBI STATUS
15.110 IN.....	NONRESET CNTR
15.110 IN.....	RESET CNTR1
15.110 IN.....	RESET CNTR2
38.378 CM.....	NONRESET CNTR
38.378 CM.....	RESET CNTR1
38.378 CM.....	RESET CNTR2
FIRMWARE IN THIS PRINTER IS COPYRIGHTED	

5. Did the printer configuration label print, and is the print quality acceptable?

If...	Then...
The label printed and the print quality is acceptable	Your printer is ready for printing. Continue with the label designer program of your choice. You may use ZebraDesigner™, which you can download from http://www.zebra.com .
The label did not print	<ul style="list-style-type: none"> a. Close the Tools window and make sure that you selected the correct printer driver before you click Open Printer Tools. Try printing the label again. b. If the label still did not print, check the connections between your printer and your computer or your printer and your network. c. If necessary, modify the printer’s settings to make them match your computer’s settings.
The label prints, but with poor quality or other issues	See <i>Printing Issues</i> on page 152 for troubleshooting instructions.



Notes • _____

Printer Configuration and Adjustment

This section assists you with configuration of and adjustments to the printer.

Contents

Contents

Changing Printer Settings	92
Print Settings	93
Calibration and Diagnostic Tools	100
Network Settings	109
Language Settings	114
Sensor Settings	118
Port Settings	120
Calibrate the Ribbon and Media Sensors	122
Adjust the Printhead Pressure	127
Adjust Ribbon Tension	130
Remove Used Ribbon	131

Changing Printer Settings

This section presents the printer settings that you can change and identifies the tools for changing them. These tools include the following:

- ZPL and Set/Get/Do (SGD) commands (See the *Zebra® Programming Guide* for more information.)
- For ZT230 printers only, the printer's **user menus** (See *Idle Display, Home Menu, and User Menus on page 17* for more information.)
- The printer's **web pages** when the printer has an active wired or wireless print server connection (See the *ZebraNet Wired and Wireless Print Servers User Guide* for more information.)

Copies of the referenced manuals are available at <http://www.zebra.com/manuals>.

This section contains the following subsections:

- *Print Settings on page 93*
- *Calibration and Diagnostic Tools on page 100*
- *Network Settings on page 109*
- *Language Settings on page 114*
- *Sensor Settings on page 118*
- *Port Settings on page 120*

Print Settings

Table 5 • Print Settings



Print Darkness	Set the darkness to the lowest setting that provides good print quality. If you set the darkness too high, the label image may print unclearly, bar codes may not scan correctly, the ribbon may burn through, or the printhead may wear prematurely. If desired, use the FEED Self Test on page 167 to determine the best darkness setting.
<i>User menu item:</i>	Main Menu >  SETTINGS 
<i>Accepted values:</i>	0.0 – 30.0
<i>Related ZPL command(s):</i>	^MD, ~SD
<i>SGD command used:</i>	print.tone
<i>Printer web page:</i>	View and Modify Printer Settings > General Setup > Darkness
Print Speed	Select the speed for printing a label (given in inches per second). Slower print speeds typically yield better print quality.
<i>User menu item:</i>	Main Menu >  SETTINGS 
<i>Accepted values:</i>	2, 3, 4, 5, 6
<i>Related ZPL command(s):</i>	^PR
<i>SGD command used:</i>	medi a. speed

Table 5 • Print Settings (Continued)



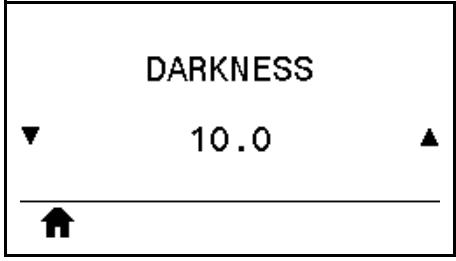

<p>Media Type</p>	<p>Select the type of media that you are using.</p> <ul style="list-style-type: none"> • If you select CONTINUOUS, you must include a label length in your label format (^LL if you are using ZPL). • If you select GAP/NOTCH or MARK for various non-continuous media, the printer feeds media to calculate the label length. <p>See Types of Media on page 19 for more information.</p> <p><i>User menu item:</i></p> <p>Main Menu >  SETTINGS</p> <div data-bbox="878 552 1328 806" style="border: 1px solid black; padding: 10px; text-align: center;"> <p>MEDIA TYPE</p> <p>▼ GAP / NOTCH ▲</p> <hr/> <p></p> </div> <p><i>Accepted values:</i></p> <ul style="list-style-type: none"> • CONTINUOUS • GAP/NOTCH • MARK <p><i>Related ZPL command(s):</i> ^MN</p> <p><i>SGD command used:</i> ezpl . medi a_type</p> <p><i>Printer web page:</i> View and Modify Printer Settings > Media Setup > Media Type</p>
<p>Print Method</p>	<p>Specify if the printer is to use Direct Thermal mode (no ribbon) or Thermal Transfer mode (using thermal transfer media and ribbon).</p> <p><i>User menu item:</i></p> <p>Main Menu >  SETTINGS</p> <div data-bbox="878 1276 1328 1530" style="border: 1px solid black; padding: 10px; text-align: center;"> <p>PRINT METHOD</p> <p>▼ THERMAL TRANS ▲</p> <hr/> <p></p> </div> <p><i>Accepted values:</i></p> <ul style="list-style-type: none"> • THERMAL TRANS • DIRECT THERMAL <p><i>Related ZPL command(s):</i> ^MT</p> <p><i>SGD command used:</i> ezpl . print_method</p> <p><i>Printer web page:</i> View and Modify Printer Settings > Media Setup > Print Method</p>

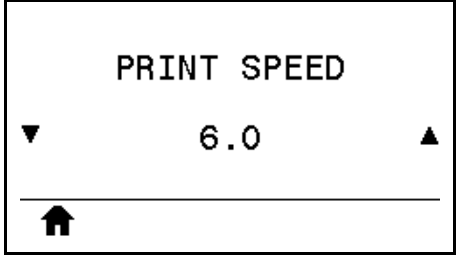
Table 5 • Print Settings (Continued)

Tear-Off Position	If necessary, adjust the position of the media over the tear-off bar after printing.					
<i>User menu item:</i>	Main Menu >  SETTINGS 					
<i>Accepted values:</i>	-120 to 120 <ul style="list-style-type: none"> • Higher numbers move the media out (the tear line moves closer to the leading edge of the next label). • Lower numbers move the media in (the tear line moves closer to the edge of the label just printed).  <table border="1" data-bbox="847 1184 1359 1310"> <tr> <td>1</td> <td>Media direction</td> </tr> <tr> <td>2</td> <td>Factory-set tear line location at position 000</td> </tr> </table>		1	Media direction	2	Factory-set tear line location at position 000
1	Media direction					
2	Factory-set tear line location at position 000					
<i>Related ZPL command(s):</i>	~TA					
<i>SGD command used:</i>	ezpl . tear_off					
<i>Printer web page:</i>	View and Modify Printer Settings > General Setup > Tear Off					

Table 5 • Print Settings (Continued)



Print Width	Specify the width of the labels being used, in dots. The default value is the maximum width for the printer, based on the printhead's DPI value.	
<i>User menu item:</i>	Main Menu >  SETTINGS <div style="border: 1px solid black; padding: 10px; text-align: center; margin: 10px auto; width: fit-content;"> <p>PRINT WIDTH</p> <p>▼ 832 ▲</p> <hr/> <p></p> </div>	
<i>Accepted values:</i>	<div style="display: flex; align-items: flex-start;"> <div style="margin-right: 10px;">  </div> <div> <p>Note • Setting the width too narrow can result in portions of a label format not being printed on the media. Setting the width too wide wastes formatting memory and can cause the printer to print off of the label and onto the platen roller. This setting can affect the horizontal position of the label format if the image was inverted using the <code>^POI</code> ZPL II command.</p> </div> </div> <p style="margin-top: 10px;">0000 to 1248 dots</p>	
<i>Related ZPL command(s):</i>	^PW	
<i>SGD command used:</i>	ezpl . pri nt_wi dth	
<i>Printer web page:</i>	View and Modify Printer Settings > Media Setup > Print Width	

Table 5 • Print Settings (Continued)

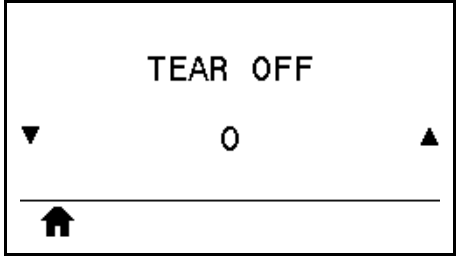
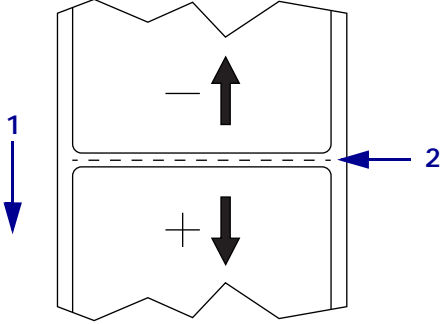

Print Mode	Select a print mode that is compatible with your printer options. For information about how the print mode selections work with different printer options, see Select a Print Mode on page 62 .	
<i>User menu item:</i>	Main Menu >  SETTINGS 	
<i>Accepted values:</i>	<ul style="list-style-type: none"> • TEAR OFF • CUTTER • PEEL (use this value for peel-off or liner take-up printing) 	
<i>Related ZPL command(s):</i>	^MM	
<i>SGD command used:</i>	medi a. pri ntmode	
<i>Printer web page:</i>	View and Modify Printer Settings > General Setup > Print Mode	
Label Left Position	If necessary, shift the print position horizontally on the label. Positive numbers move the left edge of the image toward the center of the label by the number of dots selected, while negative numbers move the left edge of the image toward the left edge of the label.	
<i>User menu item:</i>	Main Menu >  SETTINGS 	
<i>Accepted values:</i>	-9999 to 9999	
<i>Related ZPL command(s):</i>	^LS	
<i>SGD command used:</i>	zpl . l e f t _ p o s i t i o n	
<i>Printer web page:</i>	View and Modify Printer Settings > Advanced Setup > Left Position	

Table 5 • Print Settings (Continued)



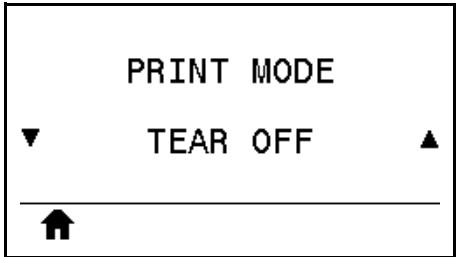

Reprint Mode	When reprint mode is enabled, you can reprint the last label printed by pressing the DOWN ARROW on the printer's control panel.	
<i>User menu item:</i>		Main Menu >  SETTINGS 
<i>Accepted values:</i>	<ul style="list-style-type: none"> • ON • OFF 	
<i>Related ZPL command(s):</i>	^JZ	
<i>SGD command used:</i>	ezpl . reprint_mode	

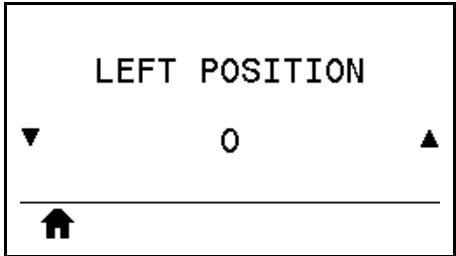
Table 5 • Print Settings (Continued)

Maximum Label Length	Set the maximum label length.							
<i>User menu item:</i>	Main Menu >  SETTINGS 							
<i>Accepted values:</i>	0 to the maximum label length supported by the printer  Important • Specify a value that is at least 1.0 in. (25.4 mm) greater than the actual label length plus the interlabel gap. If you set the value to one that is smaller than the label length, the printer assumes that continuous media is loaded, and the printer cannot calibrate. For example, if the label length is 6.0 inches (152 mm) including the interlabel gap, set the parameter for at least 7.0 inches (178 mm).  <table border="1" data-bbox="816 1619 1390 1780"> <tr> <td>1</td> <td>Label length (including interlabel gap)</td> </tr> <tr> <td>2</td> <td>Interlabel gap</td> </tr> <tr> <td>3</td> <td>Set the maximum label length to approximately this value</td> </tr> </table>		1	Label length (including interlabel gap)	2	Interlabel gap	3	Set the maximum label length to approximately this value
1	Label length (including interlabel gap)							
2	Interlabel gap							
3	Set the maximum label length to approximately this value							
<i>Related ZPL command(s):</i>	<code>^ML</code>							
<i>SGD command used:</i>	<code>ezpl . abel _l ength_max</code>							
<i>Printer web page:</i>	View and Modify Printer Settings > Media Setup > Maximum Length							

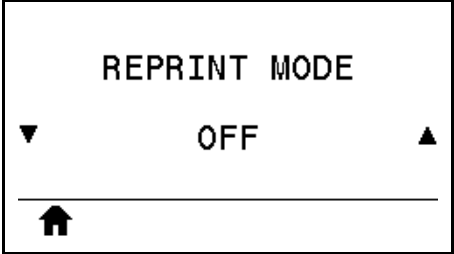
Calibration and Diagnostic Tools

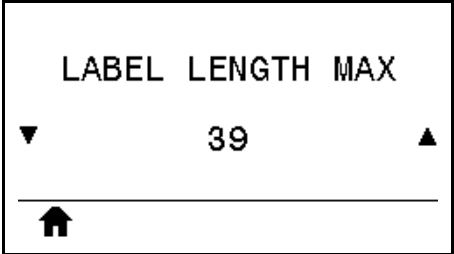
Table 6 • Calibration and Diagnostic Tools

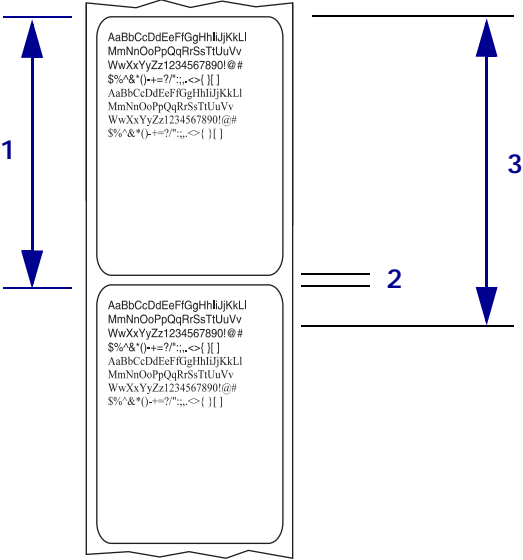





<p>Print Information</p>	<p>Print the specified information on one or more labels.</p>	
	<p><i>User menu item:</i></p>	<p>Main Menu >  TOOLS</p> <div data-bbox="878 464 1328 716" style="border: 1px solid black; padding: 5px; margin: 10px 0;"> <p style="text-align: center;">PRINT INFORMATION</p> <p style="text-align: center;">▼ SETTINGS ▲</p> <hr/> <p style="text-align: center;"> PRINT</p> </div> <p>Main Menu >  NETWORK</p> <div data-bbox="878 800 1328 1052" style="border: 1px solid black; padding: 5px; margin: 10px 0;"> <p style="text-align: center;">PRINT INFORMATION</p> <p style="text-align: center;">▼ NETWORK ▲</p> <hr/> <p style="text-align: center;"> PRINT</p> </div> <p>Main Menu >  SENSORS</p> <div data-bbox="878 1142 1328 1394" style="border: 1px solid black; padding: 5px; margin: 10px 0;"> <p style="text-align: center;">PRINT INFORMATION</p> <p style="text-align: center;">▼ SENSOR PROFILE ▲</p> <hr/> <p style="text-align: center;"> PRINT</p> </div>
<p>(Continued on next page.)</p>		

Table 6 • Calibration and Diagnostic Tools (Continued)

Print Information (continued)	<i>Accepted values:</i>	<ul style="list-style-type: none"> • SETTINGS—prints the printer configuration label. • NETWORK—prints the settings for any print server that is installed. • FORMATS—prints the available formats stored in the printer’s RAM, Flash memory, or optional memory card. • IMAGES—prints the available images stored in the printer’s RAM, Flash memory, or optional memory card. • FONTS—prints the available fonts in the printer, including standard printer fonts plus any optional fonts. Fonts may be stored in RAM or Flash memory. • BARCODES—prints the available bar codes in the printer. Bar codes may be stored in RAM or Flash memory. • ALL—prints the previous six labels. • SENSOR PROFILE—shows the sensor settings compared to actual sensor readings. To interpret the results, see <i>Sensor Profile</i> on page 172.
	<i>Related ZPL command(s):</i>	SETTINGS: ~WC NETWORK: ~WL SENSOR PROFILE: ~JG Others: ^WD
	<i>Control panel key(s):</i>	SETTINGS and NETWORK: Do one of the following: <ul style="list-style-type: none"> • Hold CANCEL during printer power-up. • Hold FEED + CANCEL for 2 seconds when the printer is in the Ready state. SENSOR PROFILE: Hold FEED + CANCEL during printer power-up.
	<i>Printer web page:</i>	View and Modify Printer Settings > Print Listings on Label
LCD Contrast	Change the contrast on the printer’s display. (ZT230 only)	
	<i>User menu item:</i>	Main Menu >  TOOLS 
	<i>Accepted values:</i>	3 to 15
	<i>SGD command used:</i>	di spl ay. contrast

Table 6 • Calibration and Diagnostic Tools (Continued)



Idle Display	Select the information shown on the printer's display when the printer is idle. (ZT230 only)	
<i>User menu item:</i>		Main Menu >  TOOLS 
<i>Accepted values:</i>		<ul style="list-style-type: none"> • FW VERSION • IP ADDRESS • MM/DD/YY 24 HR • MM/DD/YY 12 HR • DD/MM/YY 24 HR • DD/MM/YY 12 HR
<i>SGD command used:</i>		devi ce. i dl e_ di spl ay_ format
Power-Up Action	Set the action for the printer to take during the power-up sequence.	
<i>User menu item:</i>		Main Menu >  TOOLS 
<i>Accepted values:</i>		<ul style="list-style-type: none"> • CALI BRATE—adjusts sensor levels and thresholds, determines the label length, and feeds the media to the next web. • FEED—feeds the labels to the first registration point. • LENGTH—determines the label length using current sensor values, and feeds the media to the next web. • NO MOTI ON—tells the printer not to move the media. You must manually ensure that the web is positioned correctly, or press feed to position the next web. • SHORT CAL—sets the media and web thresholds without adjusting sensor gain, determines the label length, and feeds the media to the next web.
<i>Related ZPL command(s):</i>		^MF
<i>SGD command used:</i>		ezpl . power_ up_ acti on
<i>Printer web page:</i>		View and Modify Printer Settings > Calibration

Table 6 • Calibration and Diagnostic Tools (Continued)

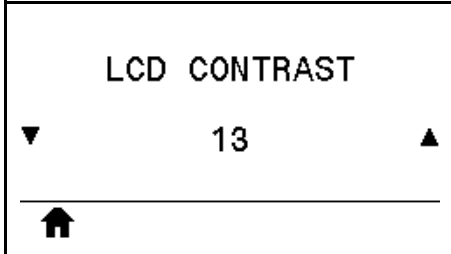
Head-Close Action	Set the action for the printer to take when you close the printhead.	
	<i>User menu item:</i>	Main Menu >  TOOLS
		
	<i>Accepted values:</i>	<ul style="list-style-type: none"> • CALIBRATE—adjusts sensor levels and thresholds, determines the label length, and feeds the media to the next web. • FEED—feeds the labels to the first registration point. • LENGTH—determines the label length using current sensor values, and feeds the media to the next web. • NO MOTION—tells the printer not to move the media. You must manually ensure that the web is positioned correctly, or press feed to position the next web. • SHORT CAL—sets the media and web thresholds without adjusting sensor gain, determines the label length, and feeds the media to the next web.
	<i>Related ZPL command(s):</i>	^MF
	<i>SGD command used:</i>	ezpl . head_cl ose_acti on
<i>Printer web page:</i>	View and Modify Printer Settings > Calibration	

Table 6 • Calibration and Diagnostic Tools (Continued)

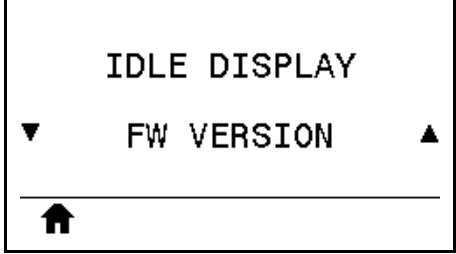

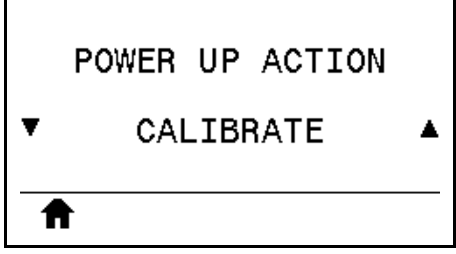

<p>Load Defaults</p>	<p>Restore specific printer, print server, and network settings back to the factory defaults. Use care when loading defaults because you will need to reload all settings that you changed manually.</p>
<p><i>User menu item:</i></p>	<p>Main Menu >  TOOLS</p> <div data-bbox="878 443 1328 695" style="border: 1px solid black; padding: 10px; text-align: center;"> <p>LOAD DEFAULTS</p> <p>▼ FACTORY ▲</p> <hr/> <p> LOAD</p> </div> <p>Main Menu >  NETWORK</p> <div data-bbox="878 779 1328 1031" style="border: 1px solid black; padding: 10px; text-align: center;"> <p>LOAD DEFAULTS</p> <p>▼ NETWORK ▲</p> <hr/> <p> LOAD</p> </div>
<p><i>Accepted values:</i></p>	<ul style="list-style-type: none"> • FACTORY—Restores all printer settings other than the network settings back to the factory defaults. Use care when loading defaults because you will need to reload all settings that you changed manually. • NETWORK—Reinitializes the printer’s wired or wireless print server. With a wireless print server, the printer also reassociates with your wireless network. • LAST SAVED—Loads settings from the last permanent save.
<p><i>Related ZPL command(s):</i></p>	<p>FACTORY: ^JUF NETWORK: ^JUN LAST SAVED: ^JUR</p>
<p><i>Control panel key(s):</i></p>	<p>FACTORY: Hold FEED + PAUSE during printer power-up to reset the printer parameters to factory values. NETWORK: Hold CANCEL + PAUSE during printer power-up to reset the network parameters to factory values. LAST SAVED: N/A</p>
<p><i>Printer web page:</i></p>	<p>FACTORY: View and Modify Printer Settings > Restore Default Configuration NETWORK: Print Server Settings > Reset Print Server LAST SAVED: View and Modify Printer Settings > Restore Saved Configuration</p>

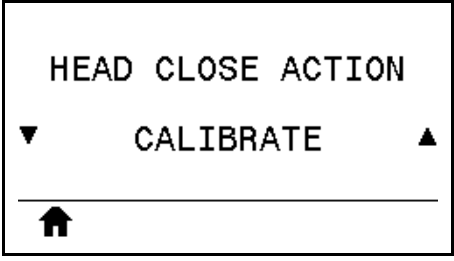
Table 6 • Calibration and Diagnostic Tools (Continued)





<p>Media and Ribbon Sensor Calibration</p>	<p>Calibrate the printer to adjust the sensitivity of the media and ribbon sensors. For complete instructions on how to perform a calibration procedure, see Calibrate the Ribbon and Media Sensors on page 122.</p>	
<p><i>User menu item:</i></p>	<p><i>User menu item:</i></p>	<p>Main Menu >  TOOLS Main Menu >  SENSORS</p> <div style="border: 1px solid black; padding: 10px; text-align: center;"> <p>MEDIA/RIBBON CAL</p> <hr/> <p> START</p> </div>
<p><i>Related ZPL command(s):</i></p>	<p>~JC</p>	
<p><i>SGD command used:</i></p>	<p>ezpl . manual _cal i brati on</p>	
<p><i>Control panel key(s):</i></p>	<p>Hold PAUSE + CANCEL for 2 seconds to initiate calibration.</p>	
<p><i>Printer web page:</i></p>	<p>The calibration procedure cannot be initiated through the web pages. See the following web page for settings that are set during sensor calibration:</p> <p style="padding-left: 40px;">View and Modify Printer Settings > Calibration</p> <p> Important • Do not change these settings unless you are told to do so by Zebra Technical Support or by an authorized service technician.</p>	

Table 6 • Calibration and Diagnostic Tools (Continued)



<p>Communication Diagnostics Mode</p>	<p>Use this diagnostics tool to cause the printer to output the hexadecimal values for all data received by the printer. For more information, see <i>Communication Diagnostics Test</i> on page 171.</p>	
<p><i>User menu item:</i></p>		<p>Main Menu >  TOOLS</p> <div style="border: 1px solid black; padding: 10px; width: fit-content; margin: 10px auto;"> <p style="text-align: center;">DIAGNOSTIC MODE</p> <p style="text-align: center;">▼ DISABLED ▲</p> <hr style="border: 0.5px solid black;"/> <p style="text-align: center;"></p> </div>
<p><i>Accepted values:</i></p>	<ul style="list-style-type: none"> • DI SABLED • ENABLED 	
<p><i>Related ZPL command(s):</i></p>	<p>~JD to enable, ~JE to disable</p>	
<p><i>SGD command used:</i></p>	<p>devi ce. di agnosti c_pri nt</p>	
<p><i>Control panel key(s):</i></p>	<p>Hold PAUSE + FEED for 2 seconds when the printer is in the Ready state.</p>	

Table 6 • Calibration and Diagnostic Tools (Continued)







<p>Enable ZBI</p>	<p>Zebra Basic Interpreter (ZBI 2.0™) is a programming option that may be purchased for your printer. If you would like to purchase this option, contact your Zebra reseller for more information.</p> <hr/> <p><i>User menu item:</i></p> <p>Main Menu >  TOOLS</p> <div data-bbox="876 436 1328 695" style="border: 1px solid black; padding: 10px; text-align: center;"> <p>ZBI ENABLED?</p> <p>NO</p> <hr/>  </div> <hr/> <p><i>SGD command used:</i></p> <p><code>zbi . key</code> (identifies if the ZBI 2.0 option is enabled or disabled on the printer)</p>
<p>Run a ZBI Program</p>	<p>If you have ZBI installed, you may choose to run a ZBI program that you have downloaded to your printer.</p> <hr/> <p><i>User menu item: *</i> * This menu item appears only if ZBI is enabled on your printer and no ZBI program is running.</p> <p>Main Menu >  TOOLS</p> <div data-bbox="876 940 1328 1192" style="border: 1px solid black; padding: 10px; text-align: center;"> <p>RUN ZBI PROGRAM</p> <p>▼ E:DIVIDE.BAS ▲</p> <hr/>  RUN </div> <p>If ZBI programs exist on your printer, they are listed. If no program exists, NONE is listed.</p> <p>If you wish to run a ZBI program that you have downloaded to your printer:</p> <ol style="list-style-type: none"> 1. Use the UP ARROW or DOWN ARROW to select a file from this menu. 2. Press RIGHT SELECT to select RUN. If no program exists, the RUN option does not perform an action. <hr/> <p><i>Related ZPL command(s):</i></p> <p><code>^JI, ~JI</code></p> <hr/> <p><i>SGD command used:</i></p> <p><code>zbi . control . run</code></p> <hr/> <p><i>Printer web page:</i></p> <p>Directory Listing</p>

Table 6 • Calibration and Diagnostic Tools (Continued)

Stop a ZBI Program	If your printer is running a ZBI program, you may stop that program.	
	<p><i>User menu item:</i></p> <p>* <i>This menu item appears only if ZBI is enabled on your printer and no ZBI program is running.</i></p>	<p>Main Menu >  TOOLS</p> <div style="border: 1px solid black; padding: 10px; text-align: center;"> <p>STOP ZBI PROGRAM</p> <hr/> <p> STOP</p> </div> <p>If ZBI programs are running, the printer lists them. If you wish to stop a program:</p> <ol style="list-style-type: none"> 1. Use the UP ARROW or DOWN ARROW to select the file from this menu. 2. Press RIGHT SELECT to select STOP.
	<i>Related ZPL command(s):</i>	~JQ
	<i>SGD command used:</i>	zbi . control . termi nate
	<i>Printer web page:</i>	Directory Listing

Network Settings

Table 7 • Network Settings



<p>IP Address</p>	<p>View and, if necessary, change the printer's IP address. To save changes to this setting, set IP Protocol on page 111 to PERMANENT, and then reset the print server (see Reset Network on page 113).</p>	
	<p><i>User menu item:</i> *</p> <p>* This menu item appears only if a wired or wireless print server is installed in your printer.</p>	<p>Main Menu >  NETWORK</p> 
	<p><i>Accepted values:</i></p>	<p>000 to 255 for each field</p>
	<p><i>Related ZPL command(s):</i></p>	<p>^ND</p>
	<p><i>SGD command used:</i></p>	<p>Wired: i n t e r n a l _ w i r e d . i p . a d d r Wireless: i p . a d d r , w l a n . i p . a d d r</p>
<p><i>Printer web page:</i></p>	<p>View and Modify Printer Settings > Network Communications Setup > TCP/IP Settings</p>	
<p>Subnet Mask</p>	<p>View and, if necessary, change the subnet mask. To save changes to this setting, set IP Protocol on page 111 to PERMANENT, and then reset the print server (see Reset Network on page 113).</p>	
	<p><i>User menu item:</i> *</p> <p>* This menu item appears only if a wired or wireless print server is installed in your printer.</p>	<p>Main Menu >  NETWORK</p> 
	<p><i>Accepted values:</i></p>	<p>000 to 255 for each field</p>
	<p><i>Related ZPL command(s):</i></p>	<p>^ND</p>
	<p><i>SGD command used:</i></p>	<p>Wired: i n t e r n a l _ w i r e d . i p . n e t m a s k Wireless: w l a n . i p . n e t m a s k</p>
<p><i>Printer web page:</i></p>	<p>View and Modify Printer Settings > Network Communications Setup > TCP/IP Settings</p>	

Table 7 • Network Settings (Continued)

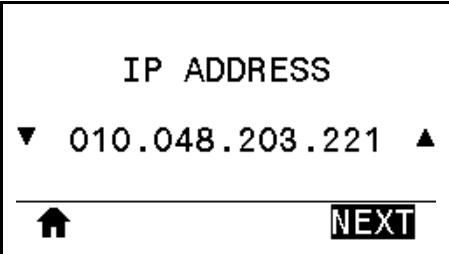

<p>Gateway</p>	<p>View or Set the Default Gateway View and, if necessary, change the default gateway. To save changes to this setting, set IP Protocol on page 111 to PERMANENT, and then reset the print server (see Reset Network on page 113).</p> <hr/> <p><i>User menu item:</i> * * This menu item appears only if a wired or wireless print server is installed in your printer.</p>
	<p>Main Menu >  NETWORK</p> <div data-bbox="894 474 1344 730" style="border: 1px solid black; padding: 10px; text-align: center;"> <p>GATEWAY</p> <p>▼ 010.048.203.254 ▲</p> <hr/> <p> NEXT</p> </div>
<i>Accepted values:</i>	000 to 255 for each field
<i>Related ZPL command(s):</i>	^ND
<i>SGD command used:</i>	Wired: i n t e r n a l _ w i r e d . i p . g a t e w a y Wireless: w l a n . i p . g a t e w a y
<i>Printer web page:</i>	View and Modify Printer Settings > Network Communications Setup > TCP/IP Settings

Table 7 • Network Settings (Continued)

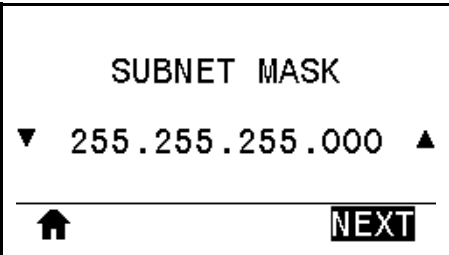
<p>IP Protocol</p>	<p>This parameter tells if the user (permanent) or the server (dynamic) selects the IP address. When a dynamic option is chosen, this parameter tells the method(s) by which the wired or wireless print server receives the IP address from the server.</p> <p><i>User menu item:</i> *</p> <p>* This menu item appears only if a wired or wireless print server is installed in your printer.</p> <p><i>Accepted values:</i></p> <ul style="list-style-type: none"> • ALL • GLEANING ONLY • RARP • BOOTP • DHCP • DHCP & BOOTP • PERMANENT <p><i>Related ZPL command(s):</i></p> <p>^ND</p> <p><i>SGD command used:</i></p> <p>Wired: internal_wired.ip.protocol Wireless: wlan.ip.protocol</p> <p><i>Printer web page:</i></p> <p>View and Modify Printer Settings > Network Communications Setup > TCP/IP Settings</p>
<p>Active Print Server</p>	<p>Only one print server (wired or wireless) can be installed at a time. Therefore, the print server installed is the active print server.</p> <p><i>User menu item:</i> *</p> <p>* This menu item appears only if a wired or wireless print server is installed in your printer. It cannot be modified from the control panel.</p> <p>Main Menu >  NETWORK</p> 

Table 7 • Network Settings (Continued)



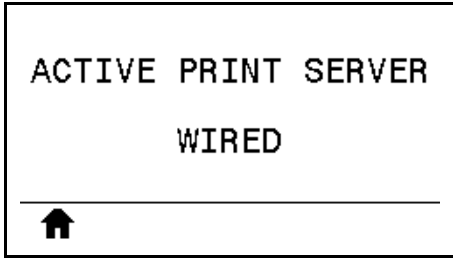

<p>MAC Address</p>	<p>View the MAC Address</p> <p>View the Media Access Control (MAC) address of the print server that is installed in the printer (wired or wireless).</p>	
	<p><i>User menu item:</i> *</p> <p>* This menu item appears only if a wired or wireless print server is installed in your printer. It cannot be modified from the control panel.</p>	<p>Main Menu >  NETWORK</p> 
	<p><i>SGD command used:</i></p>	<p>Wired: <code>internal_wired.mac_addr</code> Wireless: <code>wlan.mac_addr</code></p>
	<p><i>Printer web page:</i></p>	<p>View and Modify Printer Settings > Network Communications Setup > Wireless Setup</p>
<p>ESSID</p>	<p>View the ESSID Value</p> <p>The Extended Service Set Identification (ESSID) is an identifier for your wireless network. This setting, which cannot be modified from the control panel, gives the ESSID for the current wireless configuration.</p>	
	<p><i>User menu item:</i> *</p> <p>* This menu item appears only if a wired or wireless print server is installed in your printer. It cannot be modified from the control panel.</p>	<p>Main Menu >  NETWORK</p> 
	<p><i>Accepted values:</i></p>	<p>32-character alphanumeric string (default 125)</p>
	<p><i>SGD command used:</i></p>	<p><code>wlan.essid</code></p>
	<p><i>Printer web page:</i></p>	<p>View and Modify Printer Settings > Network Communications Setup > Wireless Setup</p>

Table 7 • Network Settings (Continued)

Reset Network	This option resets the wired or wireless print server. You must reset the print server to allow any changes to the network settings to take effect.	
<i>User menu item:</i>		Main Menu >  NETWORK 
<i>Related ZPL command(s):</i>	~WR	
<i>SGD command used:</i>	device.reset	
<i>Printer web page:</i>	Print Server Settings > Factory Print Server Settings	

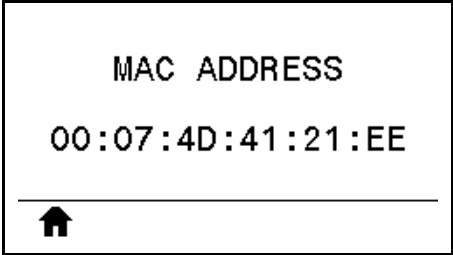
Language Settings

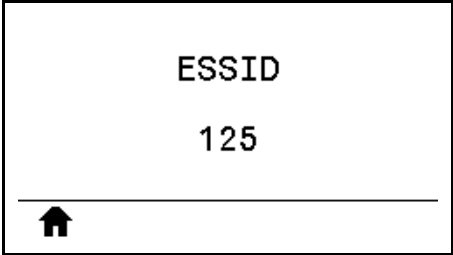
Table 8 • Language Settings

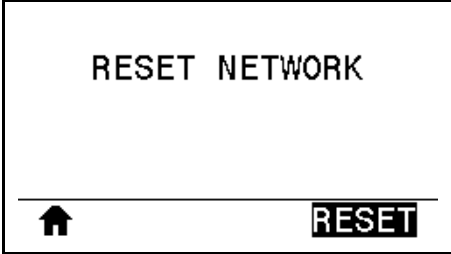



<p>Language</p>	<p>If necessary, change the language that the printer displays. This change affects the words shown on the following:</p> <ul style="list-style-type: none"> • the Home menu • the user menus • error messages • the printer configuration label, the network configuration label, and other labels that you can select to print through the user menus
<p><i>User menu item:</i></p>	<p>Main Menu >  SETTINGS Main Menu >  LANGUAGE</p> <div data-bbox="878 722 1328 978" style="border: 1px solid black; padding: 10px; text-align: center;"> <p>LANGUAGE</p> <p>▼ ENGLISH ▲</p> <hr/> <p></p> </div> <p> Note • The selections for this parameter are displayed in the actual languages to make it easier for you to find one that you are able to read.</p>
<p><i>Accepted values:</i></p>	<p>ENGLI SH, SPANI SH, FRENCH, GERMAN, I TALI AN, NORWEGI AN, PORTUGUESE, SWEDI SH, DANI SH, SPANI SH 2, DUTCH, FI NNI SH, CZECH, JAPANESE, KOREAN, ROMANI AN, RUSSI AN, POLI SH, SIMPLI FIED CHI NESE, TRADI TIONAL CHI NESE</p>
<p><i>Related ZPL command(s):</i></p>	<p>^KL</p>
<p><i>SGD command used:</i></p>	<p>di spl ay. l anguage</p>
<p><i>Printer web page:</i></p>	<p>View and Modify Printer Settings > General Setup > Language</p>

Table 8 • Language Settings (Continued)



Command Language	Enable this menu item to allow certain ZPL commands to override the printer's current settings.	
	<i>User menu item:</i>	Main Menu >  LANGUAGE 
	<i>Accepted values:</i>	<ul style="list-style-type: none"> • EPL_ZPL • HYBRID_XML_ZPL • EPL
	<i>SGD command used:</i>	devi ce. l languages
ZPL Override	Enable ZPL Override Enable this menu item to prevent the following ZPL commands from changing the printer's current settings: <ul style="list-style-type: none"> • ^MM (print mode) • ^MT (Direct Thermal or Thermal Transfer print method) • ^MN (media type non-continuous or continuous) When this menu item is disabled, these commands override the printer's settings.	
	<i>User menu item:</i>	Main Menu >  LANGUAGE 
	<i>Accepted values:</i>	<ul style="list-style-type: none"> • DISABLED • ENABLED
	<i>SGD command used:</i>	zpl . zpl _overri de

Table 8 • Language Settings (Continued)







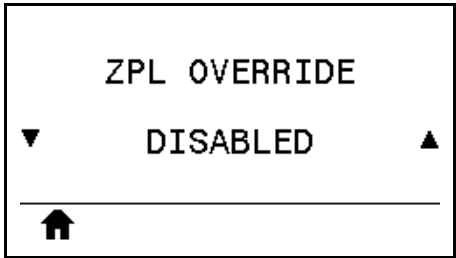

<p>Command Character</p>	<p>Set the Format Command Prefix Value</p> <p>The format command prefix is a two-digit hex value used as a parameter place marker in ZPL/ZPL II format instructions. The printer looks for this hex character to indicate the start of a ZPL/ZPL II format instruction.</p> <p>Set the format command character to match what is used in your label formats.</p> <p> Important • You cannot use the same hex value for the format command prefix, control character, and delimiter characters. The printer must see different characters to work properly. If you are setting the value through the control panel, the printer will skip any value that is already in use.</p> <p><i>User menu item:</i></p> <p>Main Menu >  LANGUAGE</p> <div data-bbox="878 659 1328 915" style="border: 1px solid black; padding: 5px; text-align: center;"> <p>COMMAND CHAR</p> <p>▼ ^ (5E) ▲</p> <hr/> <p></p> </div> <p><i>Accepted values:</i> 00 to FF</p> <p><i>Related ZPL command(s):</i> ^CC or ~CC</p> <p><i>SGD command used:</i> zpl . caret</p> <p><i>Printer web page:</i> View and Modify Printer Settings > ZPL Control</p>
<p>Control Character</p>	<p>The printer looks for this two-digit hex character to indicate the start of a ZPL/ZPL II control instruction. Set the control prefix character to match what is used in your label formats.</p> <p><i>User menu item:</i></p> <p>Main Menu >  LANGUAGE</p> <div data-bbox="878 1306 1328 1562" style="border: 1px solid black; padding: 5px; text-align: center;"> <p>CONTROL CHAR</p> <p>▼ ~ (7E) ▲</p> <hr/> <p></p> </div> <p><i>Accepted values:</i> 00 to FF</p> <p><i>Related ZPL command(s):</i> ^CT or ~CT</p> <p><i>SGD command used:</i> zpl . control_character</p> <p><i>Printer web page:</i> View and Modify Printer Settings > ZPL Control</p>

Table 8 • Language Settings (Continued)

Delimiter Character	Set the Delimiter Character Value	
	The delimiter character is a two-digit hex value used as a parameter place marker in ZPL/ZPL II format instructions. Set the delimiter character to match what is used in your label formats.	
	<i>User menu item:</i>	Main Menu >  LANGUAGE
		
	<i>Accepted values:</i>	00 to FF
	<i>Related ZPL command(s):</i>	^CD or -CD
	<i>SGD command used:</i>	zpl . del i mi ter
	<i>Printer web page:</i>	View and Modify Printer Settings > ZPL Control
ZPL Mode	Set the ZPL Mode	
	Select the mode that matches what is used in your label formats. This printer accepts label formats written in either ZPL or ZPL II, eliminating the need to rewrite any ZPL formats that already exist. The printer remains in the selected mode until it is changed in one of the ways listed here.	
	<i>User menu item:</i>	Main Menu >  LANGUAGE
		
	<i>Accepted values:</i>	<ul style="list-style-type: none"> • ZPL II • ZPL
	<i>Related ZPL command(s):</i>	^SZ
	<i>SGD command used:</i>	zpl . zpl _mode
	<i>Printer web page:</i>	View and Modify Printer Settings > ZPL Control

Sensor Settings

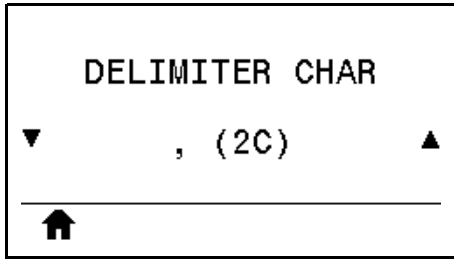
Table 9 • Sensor Settings

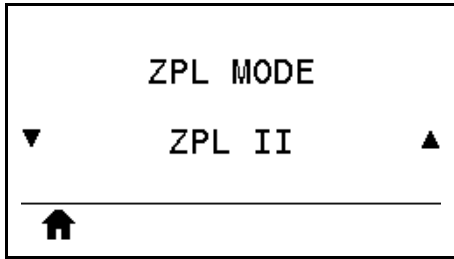



Sensor Type	Select the media sensor that is appropriate for the media that you are using. The reflective sensor can be used with all media types. The transmissive sensor should be used only for simple gap media.	
<i>User menu item:</i>		Main Menu >  SENSORS 
<i>Accepted values:</i>	<ul style="list-style-type: none"> • TRANSMISSIVE • REFLECTIVE 	
<i>Related ZPL command(s):</i>	^JS	
<i>SGD command used:</i>	device.sensor_select	
<i>Printer web page:</i>	View and Modify Printer Settings > Media Setup	
Label Sensor	Set the sensitivity of the label sensor.  Important • This value is set during sensor calibration. Do not change this setting unless you are told to do so by Zebra Technical Support or by an authorized service technician.	
<i>User menu item:</i>		Main Menu >  SENSORS 
<i>Accepted values:</i>	0 – 255	
<i>SGD command used:</i>	ezpl.label_sensor	
<i>Printer web page:</i>	View and Modify Printer Settings > Calibration	

Table 9 • Sensor Settings (Continued)

<p>Take Label</p>	<p>Set the intensity of the take label LED.</p> <p> Important • This value is set during sensor calibration. Do not change this setting unless you are told to do so by Zebra Technical Support or by an authorized service technician.</p>	
<p><i>User menu item:</i></p>	<p>Main Menu >  SENSORS</p> <div data-bbox="896 478 1344 735" style="border: 1px solid black; padding: 10px; text-align: center;"> <p>TAKE LABEL</p> <p>▼ 50 ▲</p> <hr/> <p>▲</p> </div>	
<p><i>Accepted values:</i></p>	<p>0 – 255</p>	
<p><i>SGD command used:</i></p>	<p>ezpl . take_label</p>	
<p><i>Printer web page:</i></p>	<p>View and Modify Printer Settings > Calibration</p>	

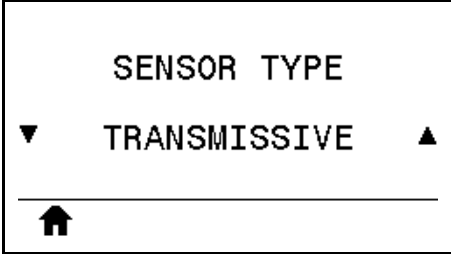
Port Settings

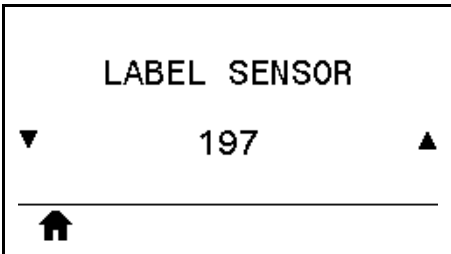
Table 10 • Port Settings







Baud Rate	Select the baud value that matches the one being used by the host computer.	
	<i>User menu item:</i>	Main Menu >  PORTS 
	<i>Accepted values:</i>	<ul style="list-style-type: none"> • 115200 • 57600 • 38400 • 28800 • 19200 • 14400 • 9600 • 4800
	<i>Related ZPL command(s):</i>	^SC
	<i>SGD command used:</i>	comm. baud
	<i>Printer web page:</i>	View and Modify Printer Settings > Serial Communications Setup
	Data Bits	Select the data bits value that matches the one being used by the host computer.
<i>User menu item:</i>		Main Menu >  PORTS 
<i>Accepted values:</i>		<ul style="list-style-type: none"> • 7 or 8
<i>Related ZPL command(s):</i>		^SC
<i>SGD command used:</i>		comm. data_bits
<i>Printer web page:</i>	View and Modify Printer Settings > Serial Communications Setup	

Table 10 • Port Settings (Continued)

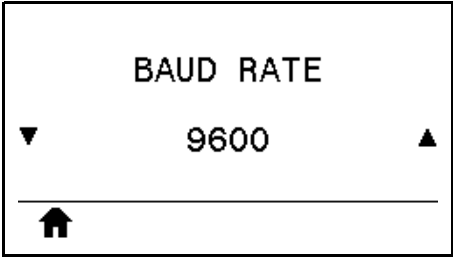
Parity	Select the parity value that matches the one being used by the host computer.	
	<i>User menu item:</i>	Main Menu >  PORTS 
	<i>Accepted values:</i>	<ul style="list-style-type: none"> • NONE • EVEN • ODD
	<i>Related ZPL command(s):</i>	^SC
	<i>SGD command used:</i>	comm. pari ty
<i>Printer web page:</i>	View and Modify Printer Settings > Serial Communications Setup	
Host Handshake	Select the handshake protocol that matches the one being used by the host computer.	
	<i>User menu item:</i>	Main Menu >  PORTS 
	<i>Accepted values:</i>	<ul style="list-style-type: none"> • XON/XOFF • RTS/CTS • DSR/DTR
	<i>Related ZPL command(s):</i>	^SC
	<i>SGD command used:</i>	comm. handshake
<i>Printer web page:</i>	View and Modify Printer Settings > Serial Communications Setup	

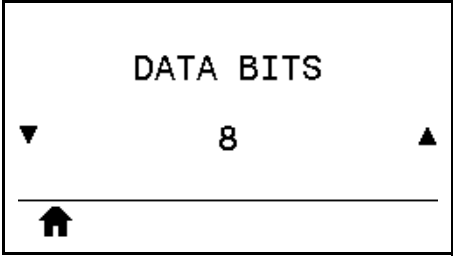
Calibrate the Ribbon and Media Sensors

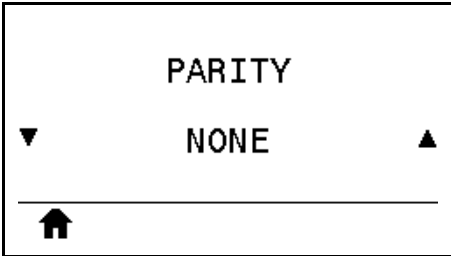
Use the procedure in this section to calibrate the printer, which adjusts the sensitivity of the media and ribbon sensors.

- For issues that may be resolved by sensor calibration, see [Printing Issues on page 152](#).
- For a summary of the options for initiating calibration, see [Media and Ribbon Sensor Calibration on page 105](#).



Important • Follow the calibration procedure exactly as presented. All of the steps must be performed even if only one of the sensors requires adjustment. You may press and hold CANCEL at any step in this procedure to cancel the process.

To perform sensor calibration, complete these steps:

1. With the printer in the Ready state, initiate media and ribbon calibration in one of these ways:
 - Press and hold **PAUSE + CANCEL** for 2 seconds.
 - Send the `ezpl.manual_calibration` SGD command to the printer. See the *Zebra Programming Guide* for more information about this command.
 - ZT230 printer only:
 - a. Navigate to the following menu item on the control panel display. This item is located under the TOOLS menu and the SENSORS menu. See [Idle Display, Home Menu, and User Menus on page 17](#) for information about using the control panel and accessing the menus.

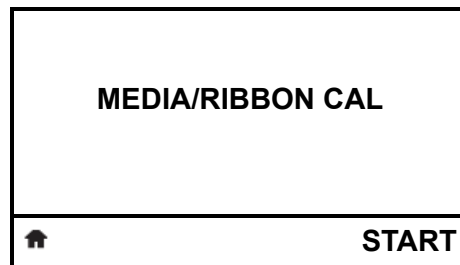

- b. Press **RIGHT SELECT** to select START.

The printer does the following:

- The **STATUS light** and **SUPPLIES light** flash yellow once.
- The **PAUSE light** blinks yellow.
- The control panel (ZT230 printer only) displays:

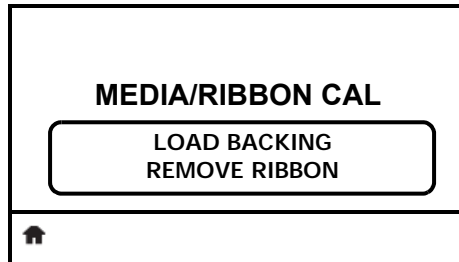

2. **Caution** • The printhead may be hot and could cause severe burns. Allow the printhead to cool.

Open the printhead assembly by rotating the printhead-open lever.

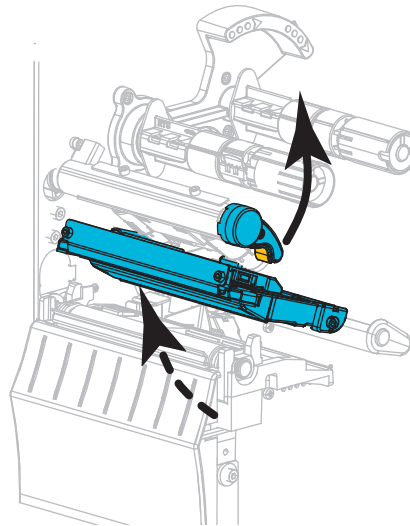

3. Extend the media approximately 8 in. (203 mm) out of the printer.

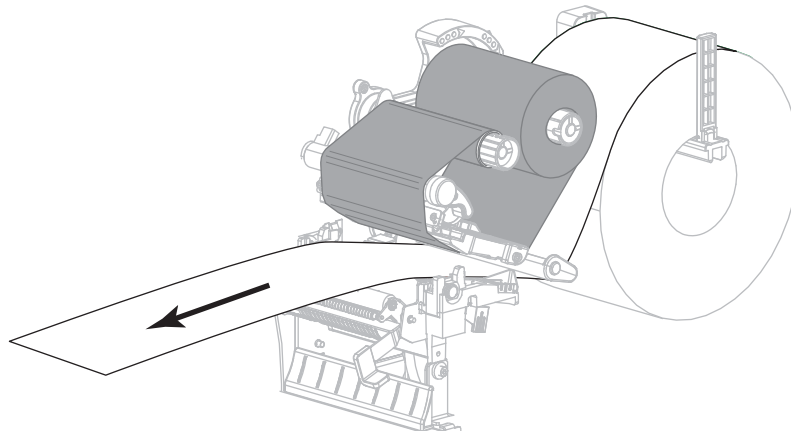

4. Remove the exposed labels so that only the liner remains.

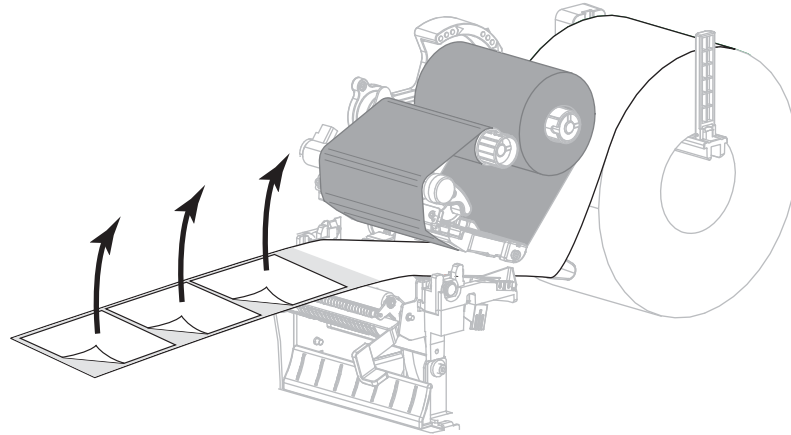

5. Pull the media into the printer so that only the backing is between the media sensors.

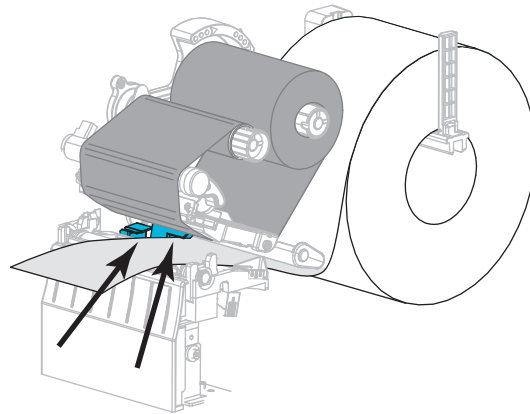

6. Remove the ribbon (if used).

7. Rotate the printhead-open lever downward until it locks the printhead in place.

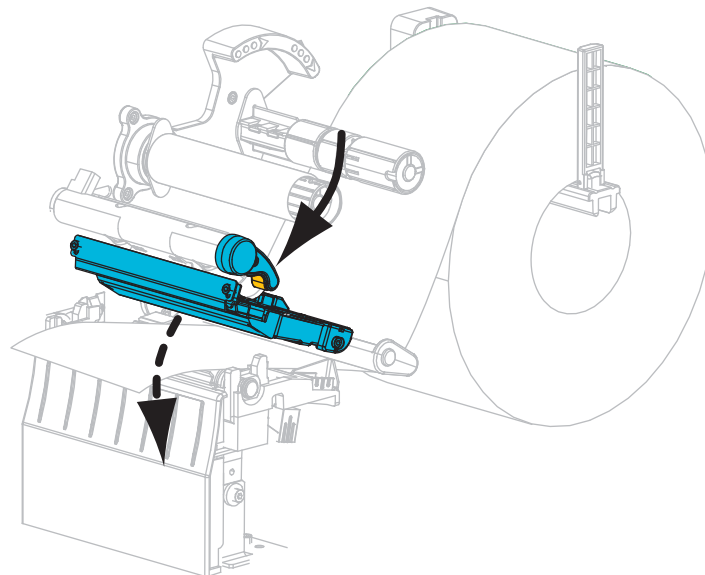

8. Press **PAUSE** to begin the media calibration process.
 - The PAUSE light turns off.
 - The SUPPLIES light flashes.
 - The control panel (ZT230 printer only) displays:

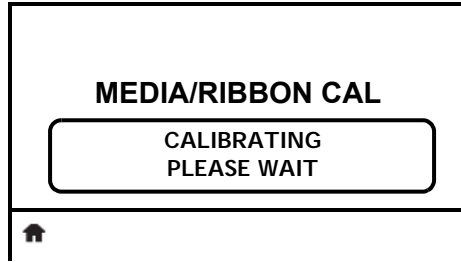

When the process is complete:

- The SUPPLIES light stops flashing.
- The PAUSE light flashes yellow.
- The control panel (ZT230 printer only) displays:

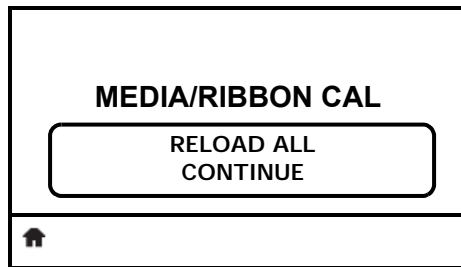

9. Open the printhead assembly by rotating the printhead-open lever.

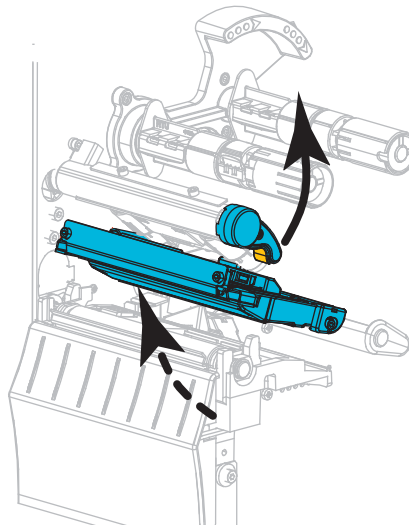

10. Pull the media forward until a label is positioned under the media sensors.

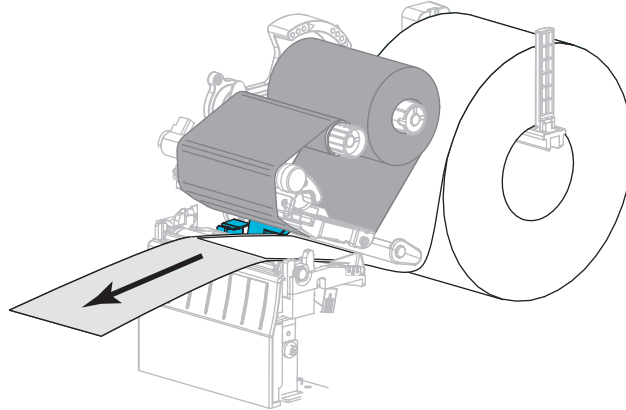

11. Reload the ribbon (if used).
12. Close the printhead.
13. Close the media door.

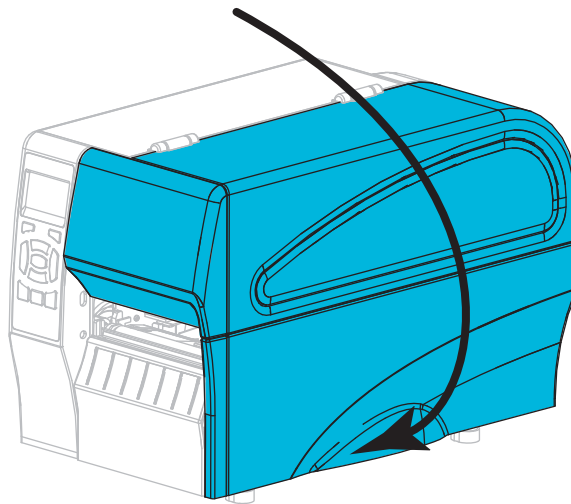

14. Press **PAUSE** to enable printing.

Adjust the Printhead Pressure

You may need to adjust printhead pressure if printing is too light on one side, if you use thick media, or if the media drifts from side to side during printing. Use the lowest printhead pressure necessary to produce good print quality.

See [Figure 16](#). The printhead pressure adjustment dials have setting marks from 1 to 4 in half-mark increments.

Figure 16 • Printhead Pressure Adjustment Dials

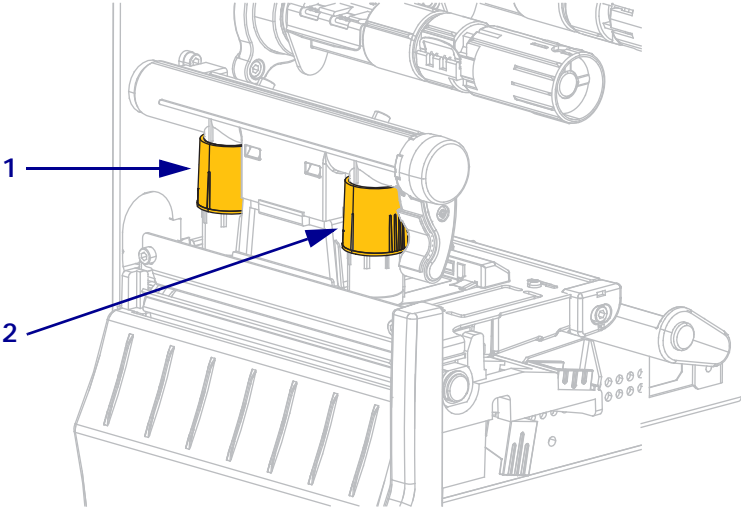

1	Inside dial
2	Outside dial

If necessary, adjust the printhead pressure adjustment dials as follows:

If the media...	Then...
Requires higher pressure to print well	Increase both dials one position.

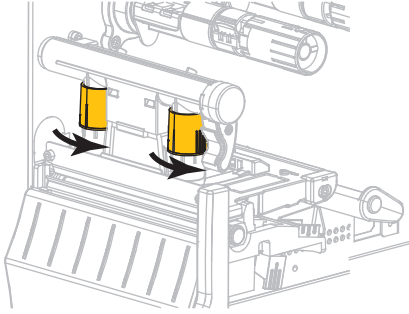

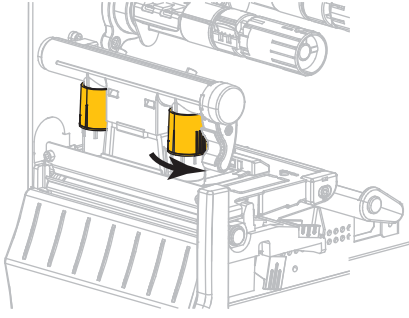
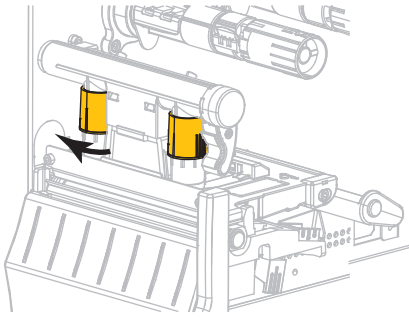
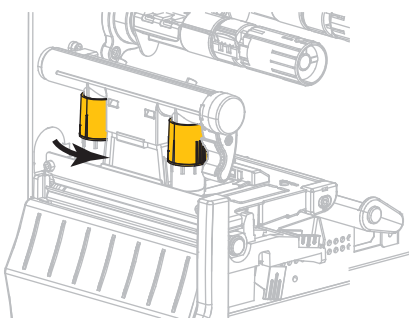
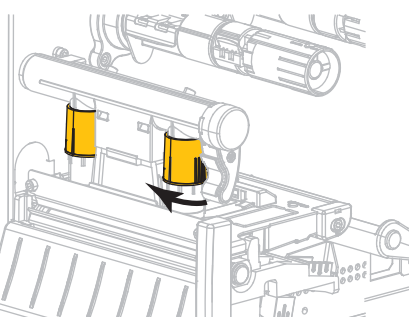
If the media...	Then...
Shifts left while printing	<p data-bbox="829 268 1481 304">Increase the outside dial setting one position.</p>  <p data-bbox="829 661 1481 697">OR</p> <p data-bbox="829 703 1481 739">Decrease the inside dial setting one position.</p> 
Shifts right while printing	<p data-bbox="829 1073 1481 1108">Increase the inside dial setting one position.</p>  <p data-bbox="829 1465 1481 1501">OR</p> <p data-bbox="829 1507 1481 1543">Decrease the outside dial setting one position.</p> 

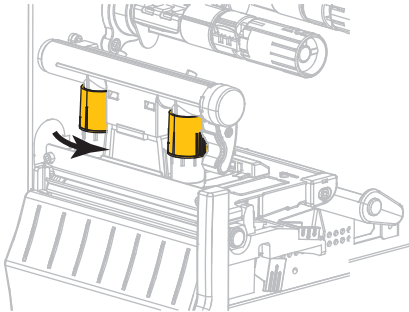
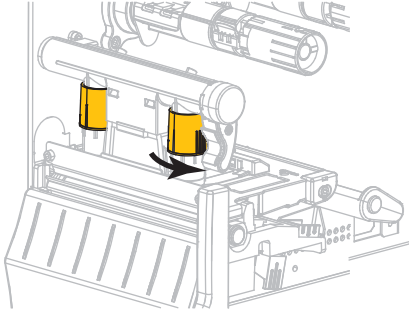
If the media...	Then...
Prints too lightly on the left side of the label.	Increase the inside dial setting one position.  A technical line drawing of a printer's printhead assembly. Two yellow cylindrical dials are highlighted. The dial on the left is rotated clockwise, as indicated by a black arrow pointing to the right.
Prints too lightly on the right side of the label.	Increase the outside dial setting one position.  A technical line drawing of a printer's printhead assembly. Two yellow cylindrical dials are highlighted. The dial on the right is rotated clockwise, as indicated by a black arrow pointing to the right.

Adjust Ribbon Tension

For the printer to operate correctly, the ribbon supply spindle and ribbon take-up spindle must use the same tension setting (normal or low tension). Use the normal tension setting (Figure 17) for most applications. If you are using narrow ribbon or experience certain ribbon issues, you may need to lower the ribbon tension (Figure 18).

Normal Tension Setting To place the ribbon spindles in the **normal position**, firmly pull out each spindle end cap until it extends and clicks in place, as shown in Figure 17. Use this setting for most applications.

Figure 17 • Normal Tension Setting (Spindle End Caps Pulled Out)

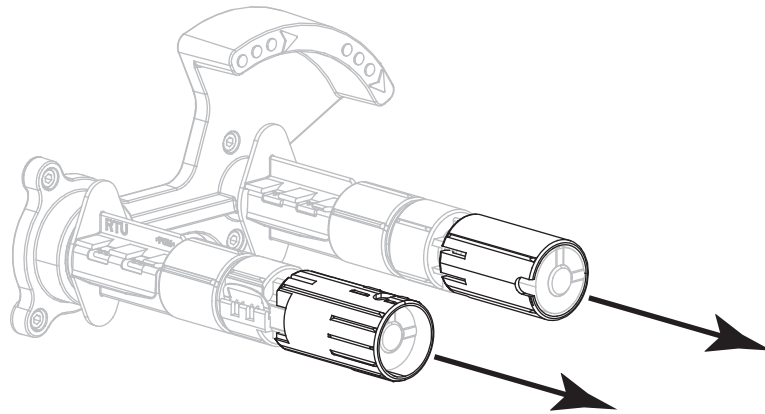

Low Tension Setting To place a spindle in the **low-tension position**, firmly push in the end cap until it retracts and clicks in place, as shown in Figure 18. Use this setting only when necessary, such as if the ribbon causes scuff marks at the beginning of a roll or if normal tension causes the ribbon to stall at the end of the roll.

Figure 18 • Ribbon Spindles— Low Tension Setting (Spindle End Caps Pushed In)

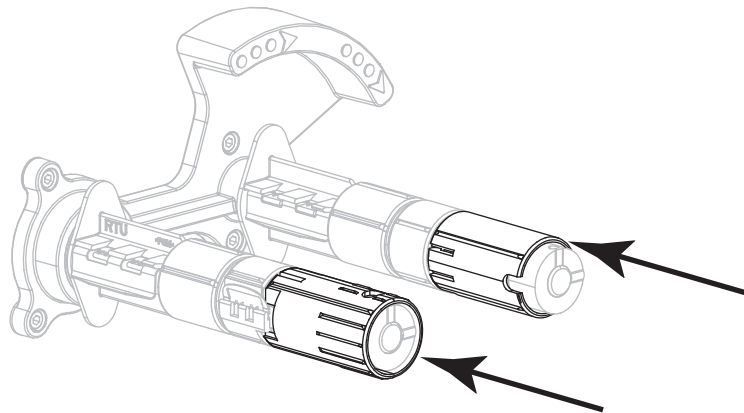

Remove Used Ribbon

Remove used ribbon from the ribbon take-up spindle each time you change the roll of ribbon.

To remove used ribbon, complete these steps:

- 1. Has the ribbon run out?

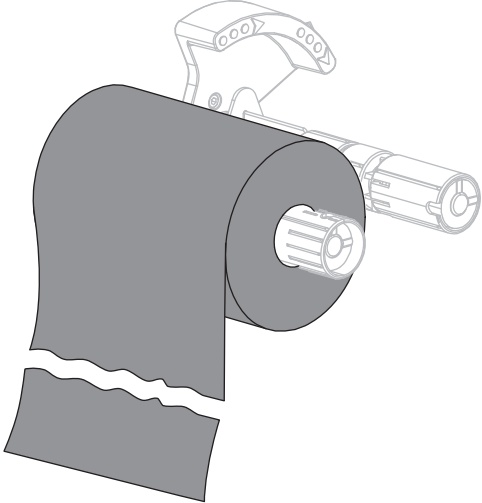
If the ribbon...	Then
Ran out	Continue with the next step.
Did not run out	<p data-bbox="755 562 1344 625">a. Cut or break the ribbon before the ribbon take-up spindle.</p>  <p data-bbox="755 1178 1105 1209">b. Continue with the next step.</p>

- 2. Slide the core with the used ribbon off of the ribbon take-up spindle.

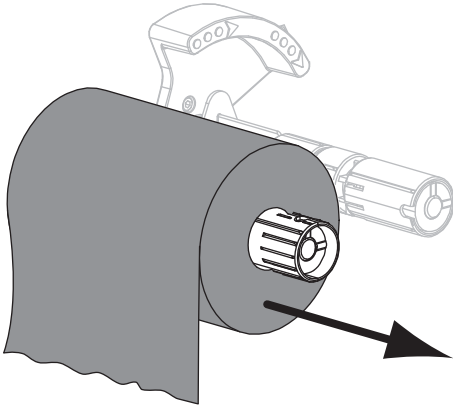

- 3. Discard the used ribbon. You may reuse the empty core from the ribbon supply spindle by moving it to the ribbon take-up spindle.
- 4. Reload the ribbon following the instructions in [Load the Ribbon on page 65](#).



Notes • _____

Routine Maintenance

This section provides routine cleaning and maintenance procedures.

Contents

Cleaning Schedule and Procedures	134
Clean the Exterior, the Media Compartment, and the Sensors	135
Clean the Printhead and Platen Roller	136
Clean the Peel Assembly	140
Clean the Cutter Module	144
Replacing Printer Components	148
Ordering Replacement Parts	148
Recycling Printer Components	148
Lubrication	148

Cleaning Schedule and Procedures

Routine preventive maintenance is a crucial part of normal printer operation. By taking good care of your printer, you can minimize the potential problems that you might have with it and help to achieve and to maintain your standards for print quality.

Over time, the movement of media or ribbon across the printhead wears through the protective ceramic coating, exposing and eventually damaging the print elements (dots). To avoid abrasion:

- Clean the printhead frequently.
- Minimize printhead pressure and burn temperature (darkness) settings by optimizing the balance between the two.
- When using Thermal Transfer mode, ensure that the ribbon is as wide or wider than the media to prevent exposing the printhead elements to the more abrasive label material.



Important • Zebra is not responsible for damage caused by the use of cleaning fluids on this printer.

Specific cleaning procedures are provided on the following pages. [Table 11](#) shows the recommended cleaning schedule. These intervals are intended as guidelines only. You may have to clean more often, depending upon your application and media.

Table 11 • Recommended Cleaning Schedule

Area		Method	Interval
Printhead		Solvent*	Direct Thermal Mode: After every roll of media (or 500 feet of fanfold media). Thermal Transfer Mode: After every roll of ribbon.
Platen roller		Solvent*	
Media sensors		Air blow	
Ribbon sensor		Air blow	
Media path		Solvent*	
Ribbon path		Solvent*	
Pinch roller (part of Peel-Off option)		Solvent*	
Cutter module	If cutting continuous, pressure-sensitive media	Solvent*	After every roll of media (or more often, depending upon your application and media).
	If cutting tag stock or label liner material	Solvent* and air blow	After every two or three rolls of media.
Tear-off/peel-off bar		Solvent*	Once a month.
Take-label sensor		Air blow	Once every six months.

* Zebra recommends using Preventive Maintenance Kit (part number 47362). In place of this kit, you may use a clean swab dipped in a solution of isopropyl alcohol (minimum 90%) and deionized water (maximum 10%).

Clean the Exterior, the Media Compartment, and the Sensors

Over time, dust, grime, and other debris may build up on the outside and inside of your printer, particularly in a harsh operating environment.

Printer Exterior

You may clean the exterior surfaces of the printer with a lint-free cloth and a small amount of a mild detergent, if necessary. Do not use harsh or abrasive cleaning agents or solvents.



Important • Zebra is not responsible for damage caused by the use of cleaning fluids on this printer.

Media Compartment and Sensors

To clean the sensors, complete these steps:

1. Brush, air blow, or vacuum any accumulated paper lint and dust away from the media and ribbon paths.
2. Brush, air blow, or vacuum any accumulated paper lint and dust away from the sensors (1).

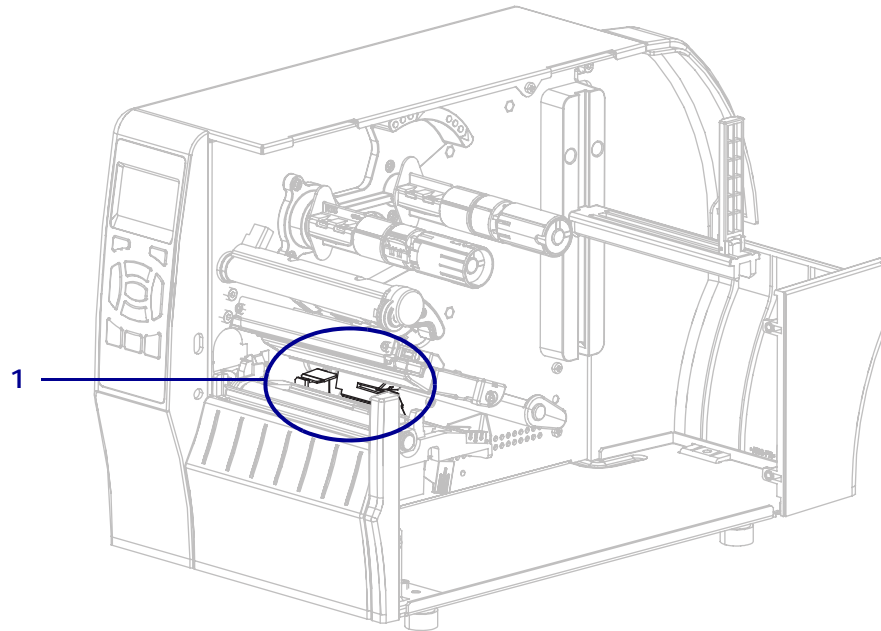

Clean the Printhead and Platen Roller

Inconsistent print quality, such as voids in the bar code or graphics, may indicate a dirty printhead. For the recommended cleaning schedule, see [Table 11 on page 134](#).

Caution • While performing any tasks near an open printhead, remove all rings, watches, hanging necklaces, identification badges, or other metallic objects that could touch the printhead. You are not required to turn off the printer power when working near an open printhead, but Zebra recommends it as a precaution. If you turn off the power, you will lose all temporary settings, such as label formats, and you must reload them before you resume printing.



Note • For printers with a peel assembly, keep the peel assembly closed while cleaning the platen roller to reduce the risk of bending the tear-off/peel-off bar.

Figure 19 • Location of the Printhead and Platen Roller

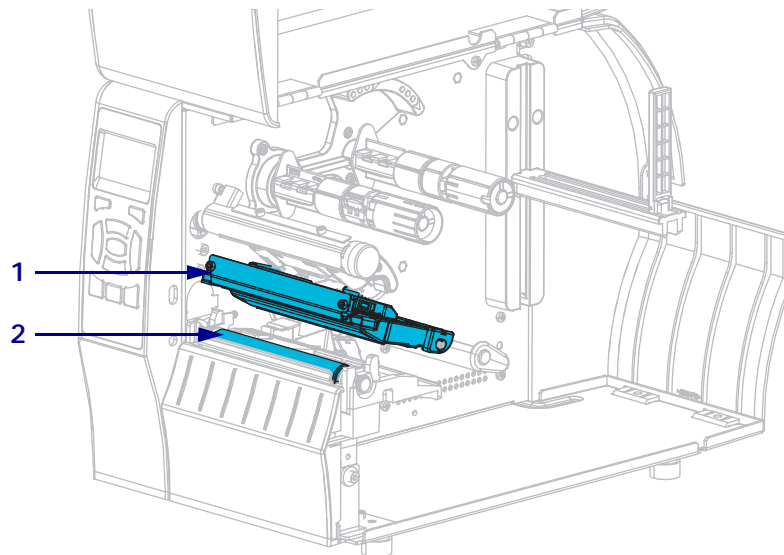

1	Printhead assembly
2	Platen roller



Caution • The printhead may be hot and could cause severe burns. Allow the printhead to cool.



Caution • Before touching the printhead assembly, discharge any built-up static electricity by touching the metal printer frame or by using an antistatic wriststrap and mat.

To clean the printhead and platen roller, complete these steps:

1. Raise the media door.

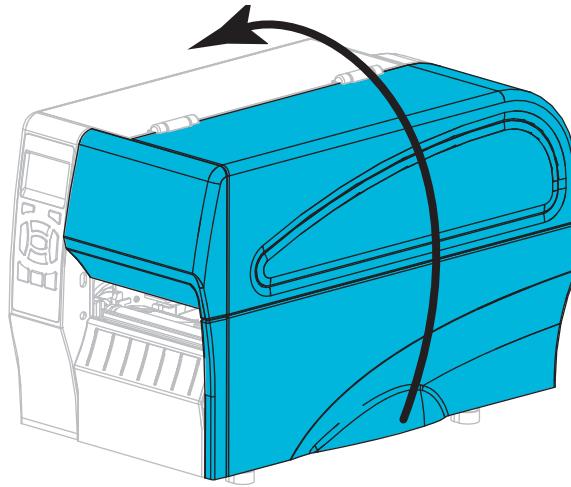

2. **Caution** • The printhead may be hot and could cause severe burns. Allow the printhead to cool.

Rotate the printhead-open lever upward to release the printhead assembly.

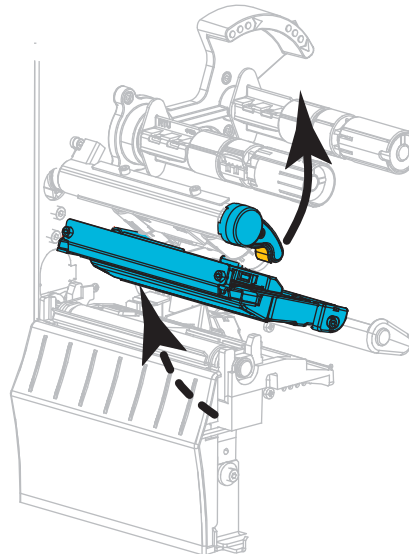

3. Remove the ribbon (if used) and the media.

4. Using the swab from a Zebra Preventive Maintenance Kit, wipe along the brown strip on the printhead assembly from end to end. In place of the Preventive Maintenance Kit, you may use a clean swab dipped in 99.7% isopropyl alcohol. Allow the solvent to evaporate.

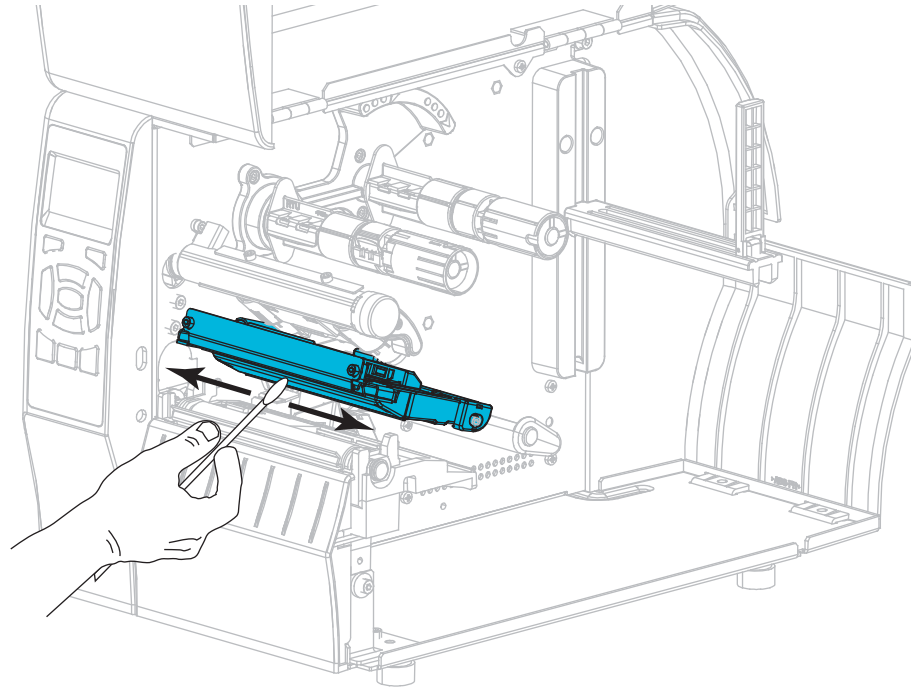

5. While manually rotating the platen roller, clean it thoroughly with the swab. Allow the solvent to evaporate.

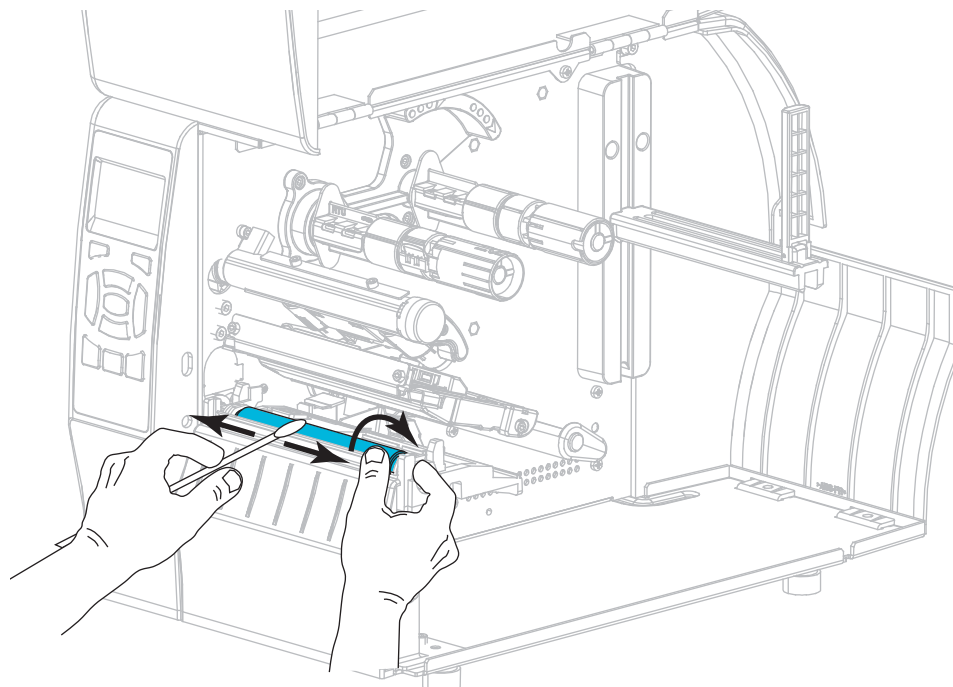

6. Reload the ribbon (if used) and the media. For instructions, see [Load the Ribbon on page 65](#) or [Load the Media on page 70](#).
7. Rotate the printhead-open lever downward until it locks the printhead in place.

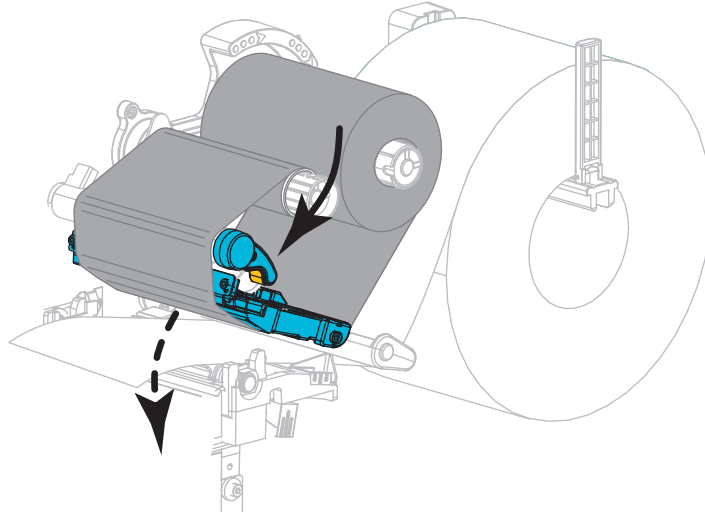

8. Close the media door.

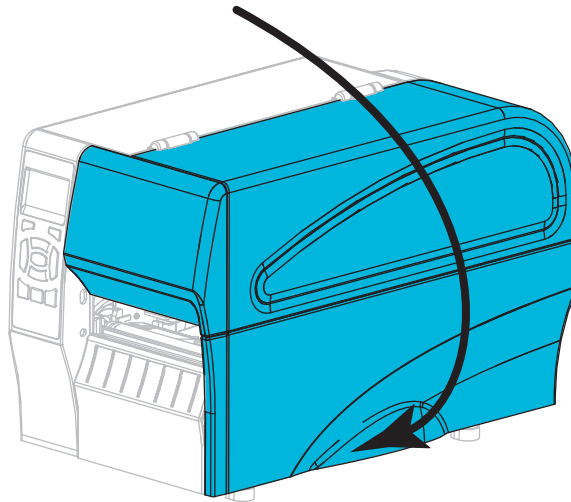

The printer is ready to operate.

9. Press **PAUSE** to exit pause mode and enable printing.
The printer may perform a label calibration or feed a label, depending on your settings.



Note • If performing this procedure does not improve print quality, try cleaning the printhead with *Save-A-Printhead* cleaning film. This specially coated material removes contamination buildup without damaging the printhead. Call your authorized Zebra reseller for more information.

Clean the Peel Assembly

The peel assembly, which is part of the Peel-Off and Liner Take-Up options, consists of several spring-loaded rollers to ensure the proper roller pressure. Clean the pinch roller and tear-off/peel-off bar if adhesive buildup begins to affect peel performance.



Caution • Do not use your left hand to assist in closing the Peel assembly. The top edge of the Peel roller/assembly could pinch your fingers.

If adhesive buildup affects peel-off performance, complete these steps:

1. Raise the media door.

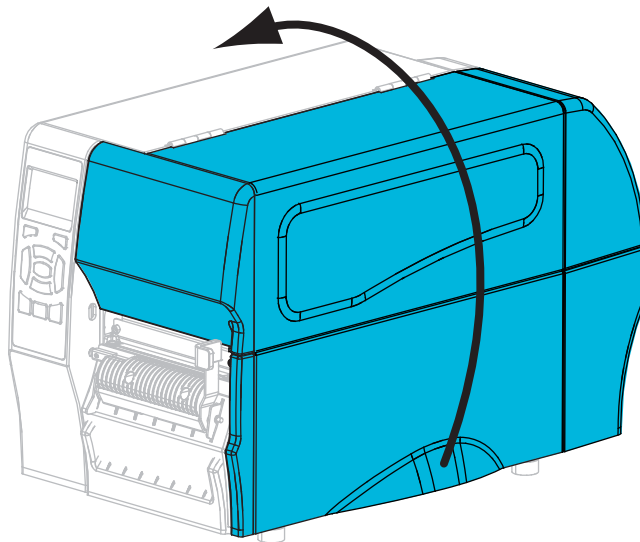

2. **Caution** • The printhead may be hot and could cause severe burns. Allow the printhead to cool.
-

Open the printhead assembly by rotating the printhead-open lever.

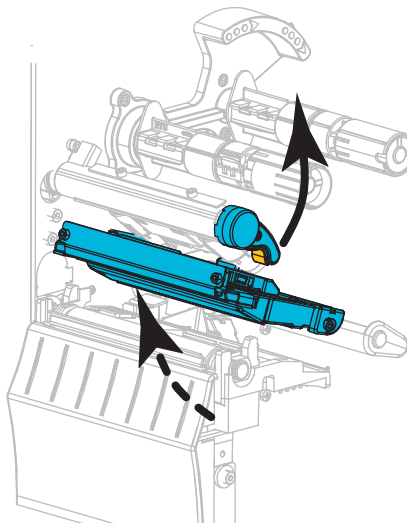

3. Push down the peel-off mechanism release lever to open the peel assembly.

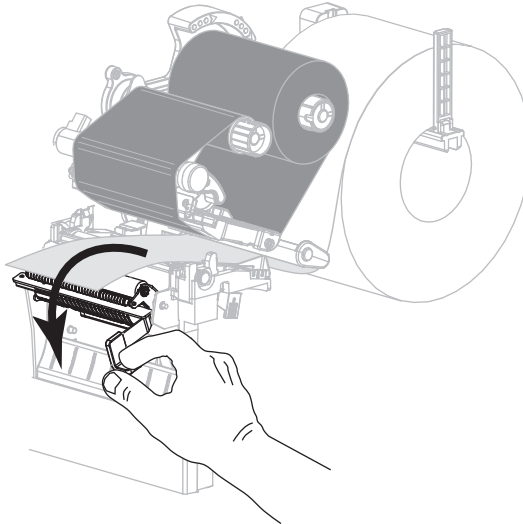

4. Remove any media liner to expose the pinch roller.
5. While manually rotating the pinch roller, clean it thoroughly with the swab from the Preventive Maintenance Kit (part number 47362). In place of the Preventive Maintenance Kit, you may use a clean swab dipped in 99.7% isopropyl alcohol. Allow the solvent to evaporate.

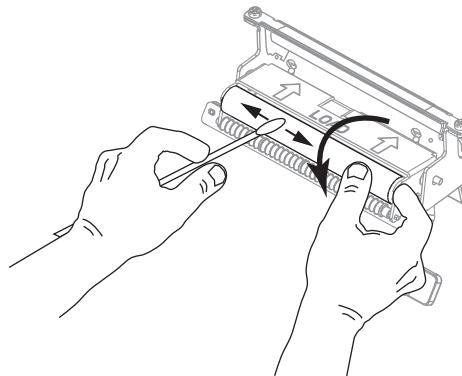

6. Use the swab to remove excess adhesive from the tear-off/peel-off bar. Allow the solvent to evaporate.



Important • Apply minimum force when cleaning the tear-off/peel-off bar. Excessive force can cause the tear-off/peel-off bar to bend, which could have a negative effect on peel performance.

7. Reload the media liner through the peel mechanism. For instructions, see [Final Steps for Peel-Off Mode \(with or without Liner Take-Up\)](#) on page 78.



-
8. **Caution** • Use the peel release lever and your right hand to close the peel assembly. Do not use your left hand to assist in closing. The top edge of the peel roller/assembly could pinch your fingers.
-

Close the peel assembly using the peel-off mechanism release lever.

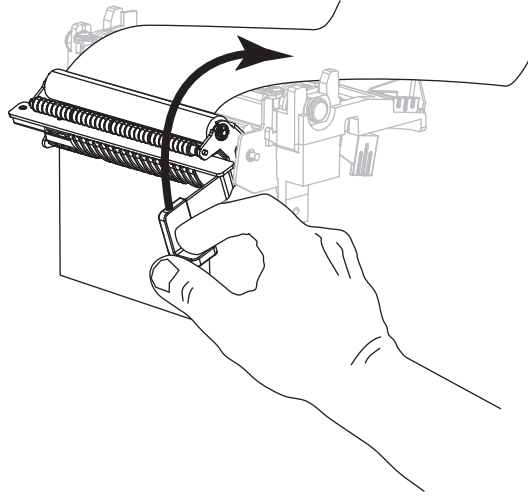

9. Rotate the printhead-open lever downward until it locks the printhead in place.

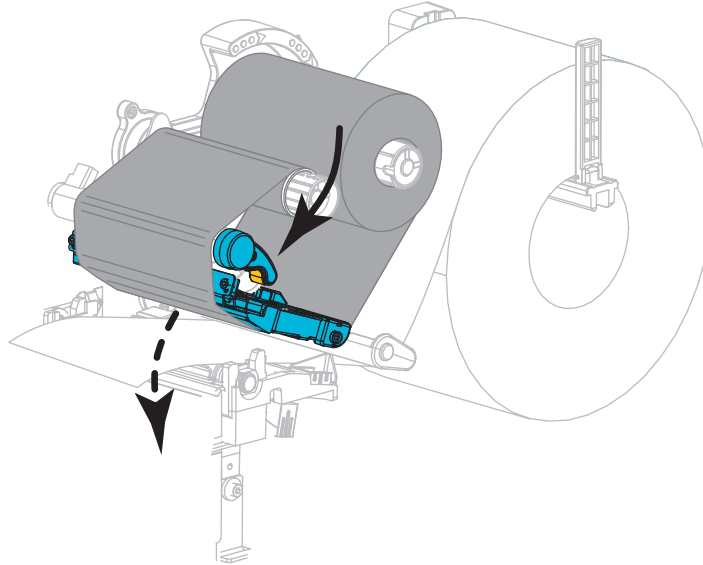

10. Close the media door.

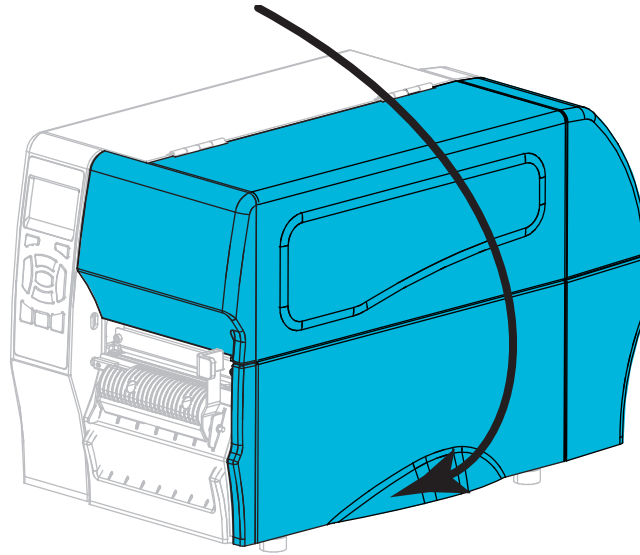

The printer is ready to operate.

11. Press **PAUSE** to exit pause mode and enable printing.
The printer may perform a label calibration or feed a label, depending on your settings.

Clean the Cutter Module

If the cutter is not cutting the labels cleanly or if it jams with labels, clean the cutter.



Caution • For personnel safety, always power off and unplug the printer before performing this procedure.

To clean the cutter module, complete these steps:

1. Raise the media door.

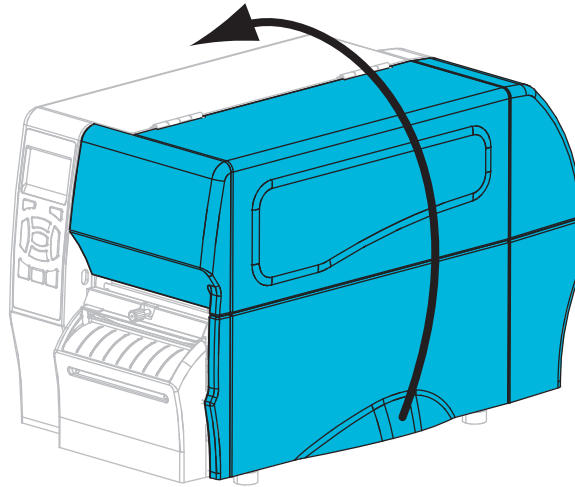

2. Turn the printer off (O), and unplug the printer from its power source.
3. Remove media that is loaded through the cutter module.
4. Loosen and remove the thumbscrew and lock washer on the cutter shield.

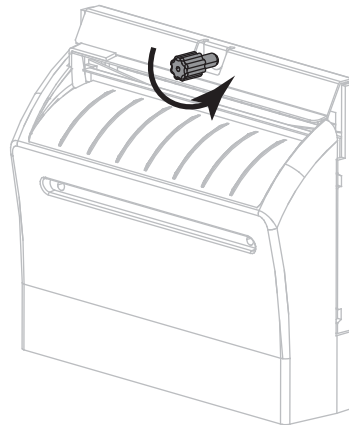



5. **Caution** • The cutter blade is sharp. Do not touch or rub the blade with your fingers.

Remove the cutter shield.

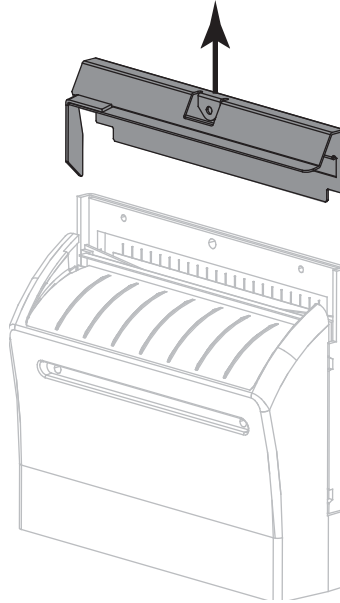

6. If necessary, rotate the cutter motor thumbscrew to fully expose the V-shaped cutter blade (1).

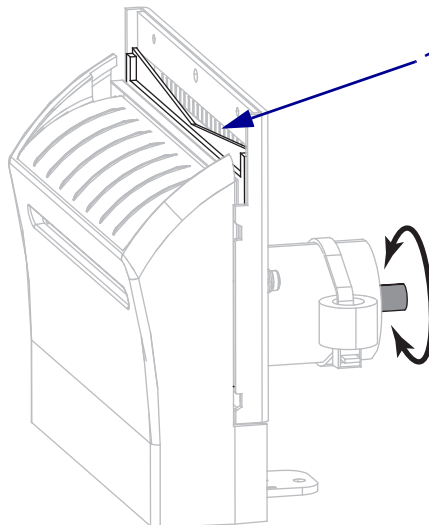

7. Using the swab from the Preventive Maintenance Kit (part number 47362), wipe along the upper cutting surface (1) and the cutter blade (2). In place of the Preventive Maintenance Kit, you may use a clean swab dipped in 99.7% isopropyl alcohol. Allow the solvent to evaporate.

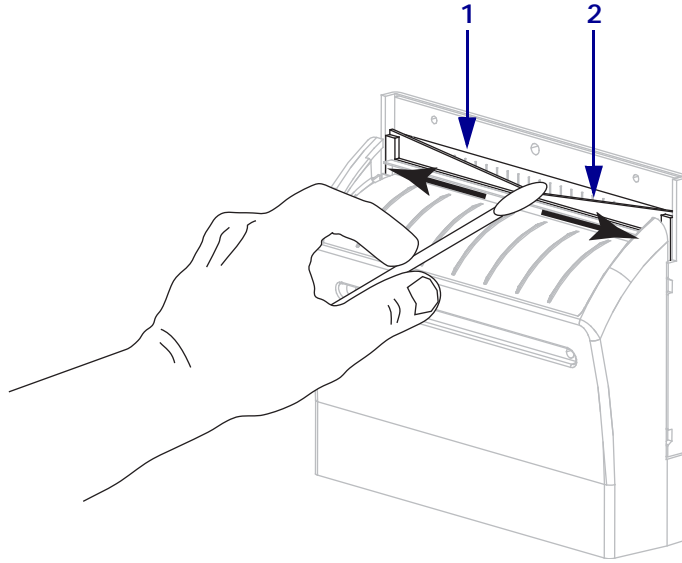

8. **Caution** • The cutter blade is sharp. For operator safety, replace the cutter shield.

Replace the cutter shield (1) and secure it with the thumbscrew and lock washer that you removed earlier (2).

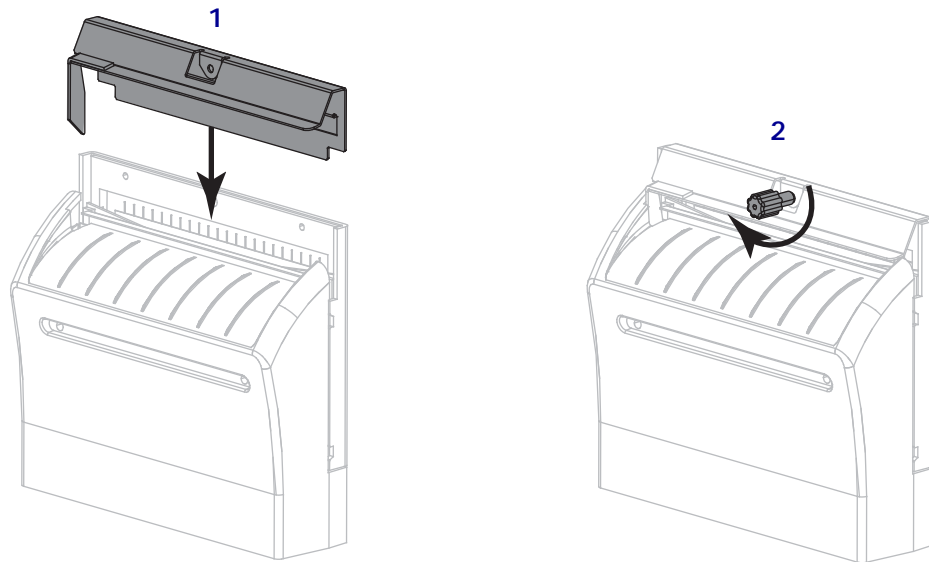

9. Close the media door.

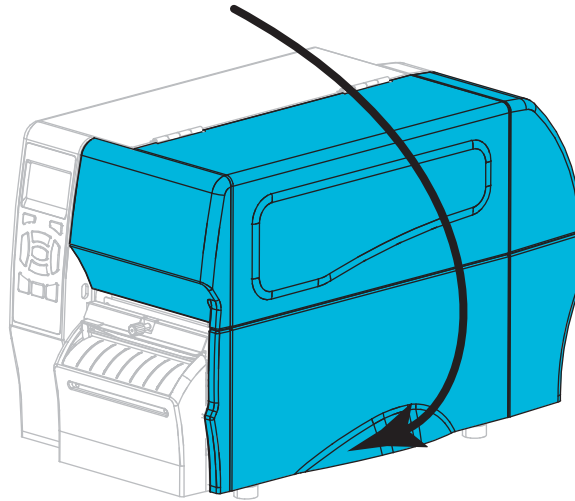

10. Plug the printer into its power source, and then turn on (I) the printer.
The cutter blade returns to its operating position.
11. If the cutter continues to perform unsatisfactorily, contact an authorized service technician.

Replacing Printer Components

Some printer components, such as the printhead and platen roller, may wear out over time and can be replaced easily. Regular cleaning may extend the life of some of these components. See [Table 11 on page 134](#) for the recommended cleaning intervals.

Ordering Replacement Parts

For optimal printing quality and proper printer performance across our product line, Zebra strongly recommends the use of genuine Zebra™ supplies as part of the total solution. Specifically, the ZT210, ZT220, and ZT230 printers are designed to work only with genuine Zebra™ printheads, thus maximizing safety and print quality.

Contact your authorized Zebra reseller for part ordering information.

Recycling Printer Components



The majority of this printer's components are recyclable. The printer's main logic board may include a battery that you should dispose of properly.

Do not dispose of any printer components in unsorted municipal waste. Please dispose of the battery according to your local regulations, and recycle the other printer components according to your local standards. For more information, see <http://www.zebra.com/environment>.

Lubrication

No lubrication is needed for this printer.

Caution • Some commercially available lubricants will damage the finish and the mechanical parts if used on this printer.

Troubleshooting

This section provides information about errors that you might need to troubleshoot. Assorted diagnostic tests are included.

For videos of some common procedures, go to <http://www.zebra.com/zt200-info>.



Contents

Printing Issues	152
Communications Problems	161
Miscellaneous Issues	162
Printer Diagnostics	164
Power-On Self Test	164
CANCEL Self Test	165
PAUSE Self Test	166
FEED Self Test	167
FEED + PAUSE Self Test	170
CANCEL + PAUSE Self Test	170
Communication Diagnostics Test	171
Sensor Profile	172

Meaning of Indicator Lights

The indicator lights on the control panel show the current status of the printer (Table 12 on page 150).

Table 12 • Status of Printer As Shown by Indicator Lights















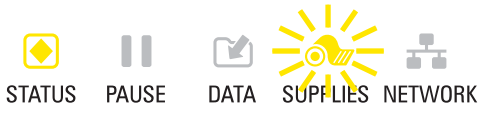

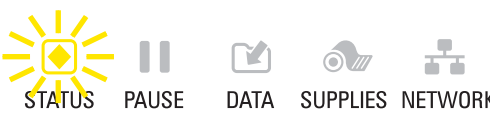

 <p>STATUS PAUSE DATA SUPPLIES NETWORK</p>	<p><i>STATUS light steady green (other lights steady yellow for 2 seconds during printer power-up)</i></p> <p>The printer is ready.</p>
 <p>STATUS PAUSE DATA SUPPLIES NETWORK</p>	<p><i>PAUSE light steady yellow.</i></p> <p>The printer is paused.</p>
 <p>STATUS PAUSE DATA SUPPLIES NETWORK</p>	<p><i>STATUS light steady red</i> <i>SUPPLIES light steady red</i></p> <p>The media supply is out. The printer needs attention and cannot continue without user intervention.</p>
 <p>STATUS PAUSE DATA SUPPLIES NETWORK</p>	<p><i>STATUS light steady red</i> <i>SUPPLIES light flashing red</i></p> <p>The ribbon supply is out. The printer needs attention and cannot continue without user intervention.</p>
 <p>STATUS PAUSE DATA SUPPLIES NETWORK</p>	<p><i>STATUS light steady yellow</i> <i>SUPPLIES light flashing yellow</i></p> <p>The printer is in Direct Thermal mode, which does not require ribbon; however, ribbon is installed in the printer.</p>
 <p>STATUS PAUSE DATA SUPPLIES NETWORK</p>	<p><i>STATUS light steady red</i> <i>PAUSE light steady yellow</i></p> <p>The printhead is open. The printer needs attention and cannot continue without user intervention.</p>
 <p>STATUS PAUSE DATA SUPPLIES NETWORK</p>	<p><i>STATUS light steady yellow</i></p> <p>The printhead is over temperature.</p> <p> Caution • The printhead may be hot and could cause severe burns. Allow the printhead to cool.</p>
 <p>STATUS PAUSE DATA SUPPLIES NETWORK</p>	<p><i>STATUS light flashing yellow</i></p> <p>This indicator light flashing indicates one of the following:</p> <ul style="list-style-type: none"> • The printhead is under temperature. • The power supply is over temperature. • The main logic board (MLB) is over temperature.
 <p>STATUS PAUSE DATA SUPPLIES NETWORK</p>	<p><i>STATUS light steady red</i> <i>PAUSE light steady red</i> <i>DATA light steady red</i></p> <p>The printhead was replaced with one that is not a genuine Zebra™ printhead. Install a genuine Zebra™ printhead to continue.</p>

Table 12 • Status of Printer As Shown by Indicator Lights (Continued)

	<p><i>STATUS light flashing red</i> The printer is unable to read the dpi setting of the printhead.</p>
<p>Printers with a ZebraNet wired Ethernet option</p>	
	<p><i>NETWORK light off</i> No Ethernet link is available.</p>
	<p><i>NETWORK light steady green</i> A 100 Base link was found.</p>
	<p><i>NETWORK light steady yellow</i> A 10 Base link was found.</p>
	<p><i>NETWORK light steady red</i> An Ethernet error condition exists. The printer is not connected to your network.</p>
<p>Printers with a ZebraNet wireless option</p>	
	<p><i>NETWORK light off</i> A radio was found during power-up. The printer is attempting to associate with the network. The light flashes red while the printer associates with the network. The light then flashes yellow while the printer is authenticating with the network.</p>
	<p><i>NETWORK light steady green</i> The radio is associated with your network and authenticated, and the WLAN signal is strong.</p>
	<p><i>NETWORK light flashing green</i> WLAN—The radio is associated with your network and authenticated, but the WLAN signal is weak.</p>
	<p><i>NETWORK light steady red</i> A WLAN error condition exists. The printer is not connected to your network.</p>

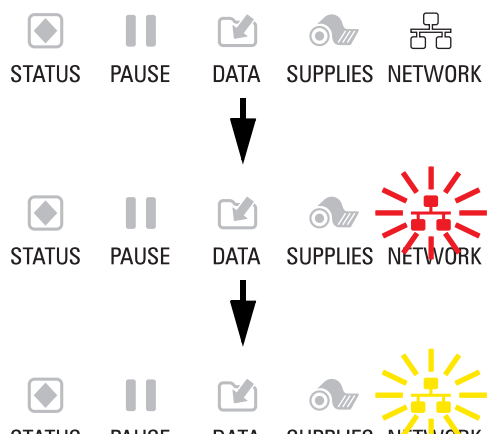
Printing Issues

Table 13 identifies possible issues with printing or print quality, the possible causes, and the recommended solutions.

Table 13 • Printing Issues

Issue	Possible Cause	Recommended Solution
General print quality issues	The printer is set at the incorrect print speed.	For optimal print quality, set the print speed to the lowest possible setting for your application via control panel, the driver, or the software. You may want to perform the <i>FEED Self Test</i> on page 167 to determine the optimal settings for your printer. See <i>Print Speed</i> on page 93 for how to change the print speed.
	You are using an incorrect combination of labels and ribbon for your application.	<ol style="list-style-type: none"> 1. Switch to a different type of media or ribbon to try to find a compatible combination. 2. If necessary, consult your authorized Zebra reseller or distributor for information and advice.
	The printer is set at an incorrect darkness level.	For optimal print quality, set the darkness to the lowest possible setting for your application. You may want to perform the <i>FEED Self Test</i> on page 167 to determine the ideal darkness setting. See <i>Print Darkness</i> on page 93 for how to change the darkness setting.
	The printhead is dirty.	Clean the printhead and platen roller. See <i>Clean the Printhead and Platen Roller</i> on page 136.
	Incorrect or uneven printhead pressure.	Set the printhead pressure to the minimum needed for good print quality. See <i>Adjust the Printhead Pressure</i> on page 127.
Loss of printing registration on labels. Excessive vertical drift in top-of-form registration.	The platen roller is dirty.	Clean the printhead and platen roller. See <i>Clean the Printhead and Platen Roller</i> on page 136.
	Media guides are positioned improperly.	Ensure that the media guides are properly positioned. See <i>Load the Media</i> on page 70.
	The media type is set incorrectly.	Set the printer for the correct media type (gap/notch, continuous, or mark). See <i>Media Type</i> on page 94.
	The media is loaded incorrectly.	Load media correctly. See <i>Load the Media</i> on page 70.
Long tracks of missing print on several labels	Print element damaged.	(UGs) Call a service technician.
	Wrinkled ribbon.	See wrinkled ribbon causes and solutions in <i>Ribbon Problems</i> on page 155.

Table 13 • Printing Issues (Continued)

Issue	Possible Cause	Recommended Solution
Fine, angular gray lines on blank labels	Wrinkled ribbon.	See wrinkled ribbon causes and solutions in <i>Ribbon Problems</i> on page 155.
Printing too light or too dark over the entire label	The media or ribbon is not designed for high-speed operation.	Replace supplies with those recommended for high-speed operation.
	You are using an incorrect combination of media and ribbon for your application.	<ol style="list-style-type: none"> 1. Switch to a different type of media or ribbon to try to find a compatible combination. 2. If necessary, consult your authorized Zebra reseller or distributor for information and advice.
	You are using ribbon with direct thermal media.	Direct thermal media does not require ribbon. To determine if you are using direct thermal media, perform the label scratch test in <i>When to Use Ribbon</i> on page 21.
	Incorrect or uneven printhead pressure.	Set the printhead pressure to the minimum needed for good print quality. See <i>Adjust the Printhead Pressure</i> on page 127.
Smudge marks on labels	The media or ribbon is not designed for high-speed operation.	Replace supplies with those recommended for high-speed operation.
Misregistration/skips labels	The printer is not calibrated.	Calibrate the printer. See <i>Calibrate the Ribbon and Media Sensors</i> on page 122.
	Improper label format.	Check your label format and correct it as necessary.
Misregistration and misprint of one to three labels	The platen roller is dirty.	Clean the printhead and platen roller. See <i>Clean the Printhead and Platen Roller</i> on page 136.
	Media does not meet specifications.	Use media that meets specifications. See <i>Media Specifications</i> on page 181.
Vertical drift in top-of-form position	The printer is out of calibration.	Calibrate the printer. See <i>Calibrate the Ribbon and Media Sensors</i> on page 122.
	The platen roller is dirty.	Clean the printhead and platen roller. See <i>Clean the Printhead and Platen Roller</i> on page 136.

Table 13 • Printing Issues (Continued)

Issue	Possible Cause	Recommended Solution
Vertical image or label drift	The printer is using non-continuous labels but is configured in continuous mode.	Set the printer for the correct media type (gap/notch, continuous, or mark—see Media Type on page 94) and calibrate the printer, if necessary (see Calibrate the Ribbon and Media Sensors on page 122).
	The media sensor is calibrated improperly.	Calibrate the printer. See Calibrate the Ribbon and Media Sensors on page 122 .
	The platen roller is dirty.	Clean the printhead and platen roller. See Clean the Printhead and Platen Roller on page 136 .
	Improper printhead pressure settings (toggles).	Adjust the printhead pressure to ensure proper functionality. See Adjust the Printhead Pressure on page 127 .
	The media or ribbon is loaded incorrectly.	Ensure that the media and ribbon are loaded correctly. See Load the Ribbon on page 65 and Load the Media on page 70 .
	Incompatible media.	You must use media that meets the printer specifications. Ensure that the interlabel gaps or notches are 2 to 4 mm and consistently placed (see Media Specifications on page 181).
The bar code printed on a label does not scan.	The bar code is not within specifications because the print is too light or too dark.	Perform the FEED Self Test on page 167 . Adjust the darkness or print speed settings as necessary.
	There is not enough blank space around the bar code.	Leave at least 1/8 in. (3.2 mm) between the bar code and other printed areas on the label and between the bar code and the edge of the label.
Auto Calibrate failed.	The media or ribbon is loaded incorrectly.	Ensure that the media and ribbon are loaded correctly. See Load the Ribbon on page 65 and Load the Media on page 70 .
	The sensors could not detect the media or ribbon.	Calibrate the printer. See Calibrate the Ribbon and Media Sensors on page 122 .
	The sensors are dirty or positioned improperly.	Ensure that the sensors are clean and properly positioned.
	The media type is set incorrectly.	Set the printer for the correct media type (gap/notch, continuous, or mark). See Media Type on page 94 .

Ribbon Problems

Table 14 identifies problems that may occur with ribbon, the possible causes, and the recommended solutions.

For videos of some common procedures, go to <http://www.zebra.com/zt200-info>.



Table 14 • Ribbon Problems

Problem	Possible Cause	Recommended Solution
Broken or melted ribbon	Darkness setting too high.	<ol style="list-style-type: none"> 1. Reduce the darkness setting. See <i>Print Darkness</i> on page 93 for how to change the darkness setting. 2. Clean the printhead thoroughly. See <i>Clean the Printhead and Platen Roller</i> on page 136.
	The ribbon is coated on the wrong side and cannot be used in this printer.	Replace the ribbon with one coated on the correct side. For more information, see <i>Coated Side of Ribbon</i> on page 21.
Ribbon slips or does not advance correctly	Ribbon tension is set incorrectly.	Change the tension settings on the ribbon spindles. See <i>Adjust Ribbon Tension</i> on page 130.
Wrinkled ribbon	Ribbon was loaded incorrectly.	Load the ribbon correctly. See <i>Load the Ribbon</i> on page 65.
	Incorrect burn temperature.	For optimal print quality, set the darkness to the lowest possible setting for your application. You may want to perform the <i>FEED Self Test</i> on page 167 to determine the ideal darkness setting. See <i>Print Darkness</i> on page 93 for how to change the darkness setting.
	Incorrect or uneven printhead pressure.	Set the printhead pressure to the minimum needed for good print quality. See <i>Adjust the Printhead Pressure</i> on page 127.
	Media not feeding properly; “walking” from side to side.	Make sure that media is snug by adjusting the media guide, or call a service technician.
	The printhead or platen roller may be installed incorrectly.	Call a service technician.

Table 14 • Ribbon Problems (Continued)

Problem	Possible Cause	Recommended Solution
<p>The printer does not detect when the ribbon runs out.</p> <hr/> <p>In thermal transfer mode, the printer did not detect the ribbon even though it is loaded correctly.</p>	<p>The printer may have been calibrated without ribbon or without the ribbon loaded properly.</p>	<ol style="list-style-type: none"> 1. Make sure that ribbon is loaded correctly so that it can be detected by the ribbon sensor. Under the printhead, the ribbon should track all the way back, near the printer's firewall. See <i>Load the Ribbon</i> on page 65. 2. Calibrate the printer. See <i>Calibrate the Ribbon and Media Sensors</i> on page 122.
<p>The printer indicates that ribbon is out, even though ribbon is loaded correctly.</p>	<p>The printer was not calibrated for the label and ribbon being used.</p>	<p>Calibrate the printer. See <i>Calibrate the Ribbon and Media Sensors</i> on page 122.</p>

Error Messages

The ZT230 control panel displays messages when there is an error. See [Table 15](#) for errors, the possible causes, and the recommended solutions.

QuickHelp Pages Most error messages will include the option to view a QuickHelp page. The lower right-hand corner of the message displays

To access a QuickHelp page from an error message, do the following:

1. Press RIGHT SELECT to select .
The printer displays a QuickHelp page specific to that error message. This page includes a QR code, such as this.



2. Scan the QR code with a smartphone.
Your phone accesses either a video specific to that error message or the Zebra support page for your printer.

Table 15 • Error Messages

Display/ Indicator Lights	Possible Cause	Recommended Solution
<div style="border: 1px solid black; border-radius: 10px; padding: 5px; text-align: center;"> HEAD OPEN CLOSE HEAD </div> STATUS light steady red PAUSE light steady yellow	The printhead is not fully closed.	Close the printhead completely.
	The printhead open sensor is not working properly.	Call a service technician to replace the sensor.
<div style="border: 1px solid black; border-radius: 10px; padding: 5px; text-align: center;"> MEDIA OUT LOAD MEDIA </div> STATUS light steady red SUPPLIES light steady red	The media is not loaded or is loaded incorrectly.	Load media correctly.
	Misaligned media sensor.	Check the position of the media sensor.
	The printer is set for noncontinuous media, but continuous media is loaded.	<ol style="list-style-type: none"> 1. Install the proper media type, or reset printer for the current media type. 2. Calibrate the printer. See Media and Ribbon Sensor Calibration on page 105.

Table 15 • Error Messages (Continued)

Display/ Indicator Lights	Possible Cause	Recommended Solution
<div style="border: 1px solid black; padding: 5px; text-align: center; margin-bottom: 10px;"> WARNING RIBBON IN </div> <p>STATUS light steady yellow SUPPLIES light flashing yellow</p>	<p>Ribbon is loaded, but the printer is set for direct thermal mode.</p>	<p>Ribbon is not required with direct thermal media. If you are using direct thermal media, remove the ribbon. This error message will not affect printing.</p> <p>If you are using thermal transfer media, which requires ribbon, set the printer for Thermal Transfer mode. See Print Method on page 94.</p>
<div style="border: 1px solid black; padding: 5px; text-align: center; margin-bottom: 10px;"> ALERT RIBBON OUT </div> <p>STATUS light steady yellow SUPPLIES light flashing yellow</p>	<p>In thermal transfer mode:</p> <ul style="list-style-type: none"> • ribbon is not loaded • ribbon is loaded incorrectly • the ribbon sensor is not detecting ribbon • media is blocking the ribbon sensor 	<ol style="list-style-type: none"> 1. Load ribbon correctly. See Load the Ribbon on page 65. 2. Calibrate the printer. See Media and Ribbon Sensor Calibration on page 105.
	<p>In thermal transfer mode, the printer did not detect the ribbon even though it is loaded correctly.</p>	<ol style="list-style-type: none"> 1. Print a sensor profile (see Print Information on page 100). The ribbon out threshold (2) is likely too high, above the line that indicates where the ribbon is detected (1).  <ol style="list-style-type: none"> 2. Calibrate the printer (see Media and Ribbon Sensor Calibration on page 105) or load printer defaults (see Load Defaults on page 104).
	<p>If you are using direct thermal media, the printer is waiting for ribbon to be loaded because it is incorrectly set for thermal transfer mode.</p>	<p>Set the printer for Direct Thermal mode. Refer to the <i>User Guide</i> for information about changing the print method.</p>

Table 15 • Error Messages (Continued)



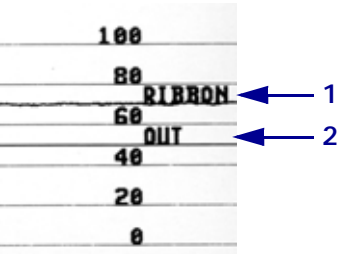

Display/ Indicator Lights	Possible Cause	Recommended Solution
<div style="border: 1px solid black; padding: 5px; text-align: center;"> PH NOT AUTHENTICATED REPLACE PRINTHEAD </div> <p>STATUS light steady red PAUSE light steady red DATA light steady red</p>	The printhead was replaced with one that is not a genuine Zebra™ printhead.	Install a genuine Zebra™ printhead.
<div style="border: 1px solid black; padding: 5px; text-align: center;"> PRINT HEAD OVERTEMP PRINTING HALTED </div> <p>STATUS light steady yellow</p>	 Caution • The printhead may be hot enough to cause severe burns. Allow the printhead to cool.	
	The printhead is over temperature.	<p>Allow the printer to cool. Printing automatically resumes when the printhead elements cool to an acceptable operating temperature.</p> <p>If this error persists, consider changing where the printer is located or using a slower print speed.</p>
<div style="border: 1px solid black; padding: 5px; text-align: center;"> HEAD COLD PRINTING HALTED </div> <div style="border: 1px solid black; padding: 5px; text-align: center; margin-top: 10px;"> THERMISTOR REPLACE PRINTHEAD </div> <p>STATUS light steady yellow The printer shows one of these messages or cycles between them.</p>	 Caution • An improperly connected printhead data or power cable can cause these error messages. The printhead may be hot enough to cause severe burns. Allow the printhead to cool.	
	The printhead data cable is not properly connected.	Call a service technician to hook up the printhead properly.
	The printhead has a faulty thermistor.	Call a service technician to replace the printhead.

Table 15 • Error Messages (Continued)

Display/ Indicator Lights	Possible Cause	Recommended Solution
<div style="border: 1px solid black; padding: 5px; text-align: center; margin-bottom: 10px;"> HEAD COLD PRINTING HALTED </div> <p>STATUS light flashing yellow</p>	<div style="display: flex; align-items: flex-start;">  <p>Caution • An improperly connected printhead data or power cable can cause this error message. The printhead may be hot enough to cause severe burns. Allow the printhead to cool.</p> </div>	<p>The printhead temperature is approaching its lower operating limit.</p> <p>Continue printing while the printhead reaches the correct operating temperature. If the error remains, the environment may be too cold for proper printing. Relocate the printer to a warmer area.</p>
	<p>The printhead data cable is not properly connected.</p>	<p>Call a service technician to hook up the printhead properly.</p>
	<p>The printhead has a faulty thermistor.</p>	<p>Call a service technician to replace the printhead.</p>
<div style="border: 1px solid black; padding: 5px; text-align: center; margin-bottom: 10px;"> CUT ERROR </div> <p>STATUS light steady red PAUSE light steady yellow</p>	<div style="display: flex; align-items: flex-start;">  <p>Caution • The cutter blade is sharp. Do not touch or rub the blade with your fingers.</p> </div>	<p>The cutter blade is in the media path.</p> <p>Turn off the printer power and unplug the printer. Inspect the cutter module for debris and clean as needed following the cleaning instructions in Clean the Cutter Module on page 144.</p>
<div style="border: 1px solid black; padding: 5px; text-align: center; margin-bottom: 10px;"> OUT OF MEMORY STORING GRAPHIC </div> <div style="border: 1px solid black; padding: 5px; text-align: center; margin-bottom: 10px;"> OUT OF MEMORY STORING FORMAT </div> <div style="border: 1px solid black; padding: 5px; text-align: center; margin-bottom: 10px;"> OUT OF MEMORY STORING BITMAP </div> <div style="border: 1px solid black; padding: 5px; text-align: center;"> OUT OF MEMORY STORING FONT </div>	<p>There is not enough memory to perform the function specified on the second line of the error message.</p>	<p>Free up some of the printer's memory by adjusting the label format or printer parameters. One way to free up memory is to adjust the print width to the actual width of the label instead of leaving the print width set to the default. See Print Width on page 96.</p> <p>Ensure that the data is not directed to a device that is not installed or is unavailable.</p> <p>If the problem persists, call a service technician.</p>

Communications Problems

Table 16 identifies problems with communications, the possible causes, and the recommended solutions.

Table 16 • Communications Problems

Problem	Possible Cause	Recommended Solution
A label format was sent to the printer but was not recognized. The DATA light does not flash.	The communication parameters are incorrect.	Check the printer driver or software communications settings (if applicable).
		If you are using serial communication, check the serial port settings. See <i>Port Settings on page 120</i> .
		If you are using serial communication, make sure that you are using a null modem cable or a null modem adapter.
		Check the printer's handshake protocol setting. The setting used must match the one being used by the host computer. See <i>Host Handshake on page 121</i> .
		If a driver is used, check the driver communication settings for your connection.
A label format was sent to the printer. Several labels print, then the printer skips, misplaces, misses, or distorts the image on the label.	The serial communication settings are incorrect.	Ensure that the flow control settings match.
		Check the communication cable length. See <i>General Specifications on page 176</i> for requirements.
		Check the printer driver or software communications settings (if applicable).
A label format was sent to the printer but was not recognized. The DATA light flashes but no printing occurs.	The prefix and delimiter characters set in the printer do not match the ones in the label format.	Verify the prefix and delimiter characters. See <i>Control Character on page 116</i> and <i>Delimiter Character on page 117</i> .
	Incorrect data is being sent to the printer.	Check the communication settings on the computer. Ensure that they match the printer settings.
		If the problem continues, check the label format.

Miscellaneous Issues

Table 17 identifies miscellaneous issues with the printer, the possible causes, and the recommended solutions.

For videos of some common procedures, go to <http://www.zebra.com/zt200-info>.



Table 17 • Miscellaneous Printer Problems

Problem	Possible Cause	Recommended Solution
The control panel display shows a language that I cannot read	The language parameter was changed through the control panel or a firmware command.	<ol style="list-style-type: none"> 1. On the control panel display, scroll to LANGUAGE Menu.  2. Press OK to access the items in this menu. 3. Use the UP ARROW or DOWN ARROW to scroll through the language selections. The selections for this parameter are displayed in the actual languages to make it easier for you to find one that you are able to read. 4. Select the language that you want to display.
The display is missing characters or parts of characters	The display may need replacing.	Call a service technician.
Changes in parameter settings did not take effect	Some parameters are set incorrectly.	<ol style="list-style-type: none"> 1. Check the parameters and change or reset if necessary. 2. Turn the printer off (O) and then on (I).
	A firmware command turned off the ability to change the parameter.	Refer to the <i>Programming Guide for ZPL, ZBI, Set-Get-Do, Mirror, and WML</i> or call a service technician.
	A firmware command changed the parameter back to the previous setting.	
	If the problem persists, there may be a problem with the main logic board.	Call a service technician.
Non-continuous labels are being treated as continuous labels.	The printer was not calibrated for the media being used.	Calibrate the printer. See <i>Calibrate the Ribbon and Media Sensors</i> on page 122.
	The printer is configured for continuous media.	Set the printer for the correct media type (gap/notch, continuous, or mark). See <i>Media Type</i> on page 94.

Table 17 • Miscellaneous Printer Problems (Continued)

Problem	Possible Cause	Recommended Solution
All indicator lights are on, nothing is on the display (if the printer has a display), and the printer locks up.	Internal electronic or firmware failure.	Call a service technician.
The printer locks up while running the Power-On Self Test.	Main logic board failure.	Call a service technician.

Printer Diagnostics

Self tests and other diagnostics provide specific information about the condition of the printer. The self tests produce sample printouts and provide specific information that helps determine the operating conditions for the printer.



Important • Use full-width media when performing self tests. If your media is not wide enough, the test labels may print on the platen roller. To prevent this from happening, check the print width, and ensure that the width is correct for the media that you are using.

Each self test is enabled by pressing a specific control panel key or combination of keys while turning on (I) the printer power. Keep the key(s) pressed until the first indicator light turns off. The selected self test automatically starts at the end of the Power-On Self Test.



Note •

- When performing these self tests, do not send data to the printer from the host.
- If your media is shorter than the label to be printed, the test label continues on the next label.
- When canceling a self test prior to its actual completion, always reset the printer by turning it off (O) and then on (I).
- If the printer is in applicator mode and the liner is being taken up by the applicator, the operator must manually remove the labels as they become available.

Power-On Self Test

A Power-On Self Test (POST) is performed each time the printer is turned on (I). During this test, the control panel lights (LEDs) turn on and off to ensure proper operation. At the end of this self test, only the STATUS LED remains lit. When the Power-On Self Test is complete, the media is advanced to the proper position.

To initiate the Power-On Self Test, complete these steps:

1. Turn on (I) the printer.

The POWER LED illuminates. The other control panel LEDs and the LCD monitor the progress and indicate the results of the individual tests. All messages during the POST display in English; however, if the test fails, the resulting messages cycle through the international languages as well.

CANCEL Self Test

The CANCEL self test prints a printer configuration label and a network configuration label. For other ways to print these labels, see [Print Information on page 100](#).

To perform the CANCEL Self Test, complete these steps:

1. Turn off (O) the printer.
2. Press and hold CANCEL while turning on (I) the printer. Hold CANCEL until the first control panel light turns off.

The printer prints a printer configuration label (Figure 20) and then a network configuration label (Figure 21).

Figure 20 • Sample Printer Configuration Label

PRINTER CONFIGURATION	
Zebra Technologies ZTC ZT230-203dpi ZPL XXXXXX-XX-XXXX	
10.....	LCD CONTRAST
+10.....	DARKNESS
2.0 IPS.....	PRINT SPEED
+000.....	TEAR OFF
TEAR OFF.....	PRINT MODE
GAP/NOTCH.....	MEDIA TYPE
REFLECTIVE.....	SENSOR SELECT
832.....	PRINT WIDTH
1422.....	LABEL LENGTH
39.0IN 989MM.....	PRINT HEAD ID
NOT CONNECTED.....	MAXIMUM LENGTH
BIDIRECTIONAL.....	USB COMM.
RS232.....	PARALLEL COMM.
2400.....	SERIAL COMM.
8 BITS.....	BAUD
NONE.....	DATA BITS
XON/XOFF.....	PARITY
NONE.....	HOST HANDSHAKE
NORMAL MODE.....	PROTOCOL
<~> 7EH.....	COMMUNICATIONS
<> 5EH.....	CONTROL PREFIX
<,> 2CH.....	FORMAT PREFIX
ZPL II.....	DELIMITER CHAR
CALIBRATION.....	ZPL MODE
CALIBRATION.....	MEDIA POWER UP
DEFAULT.....	HEAD CLOSE
+000.....	BACKFEED
+0000.....	LABEL TOP
DISABLED.....	LEFT POSITION
020.....	REPRINT MODE
024.....	WEB SENSOR
255.....	MEDIA SENSOR
027.....	TAKE LABEL
027.....	MARK SENSOR
102.....	MARK MED SENSOR
000.....	TRANS GAIN
100.....	TRANS BASE
050.....	TRANS LED
DPCSWFXM.....	MARK LED
.....	MODES ENABLED
832 8/MM FULL.....	MODES DISABLED
V72.18.12P15107 <-	RESOLUTION
1.3.....	FIRMWARE
6.4.1 255.....	XML SCHEMA
NONE.....	HARDWARE ID
12288k.....	OPTION BOARD
65536k.....	R: RAM
NONE.....	E: ONBOARD FLASH
FW VERSION.....	FORMAT CONVERT
07/20/12.....	IDLE DISPLAY
02:37.....	RTC DATE
DISABLED.....	RTC TIME
2.1.....	ZBI
READY.....	ZBI VERSION
15.110 IN.....	ZBI STATUS
15.110 IN.....	NONRESET CNTR
15.110 IN.....	RESET CNTR1
38.378 CM.....	RESET CNTR2
38.378 CM.....	NONRESET CNTR
38.378 CM.....	RESET CNTR1
38.378 CM.....	RESET CNTR2
FIRMWARE IN THIS PRINTER IS COPYRIGHTED	

Figure 21 • Sample Network Configuration Label

Network Configuration	
Zebra Technologies ZTC ZT230-203dpi ZPL XXXXXX-XX-XXXX	
PrintServer.....	LOAD LAN FROM?
INTERNAL WIRED.....	ACTIVE PRINTSRVR
Wired*	
ALL.....	IP PROTOCOL
010.003.005.104.....	IP ADDRESS
255.255.255.000.....	SUBNET
010.003.005.001.....	GATEWAY
010.003.001.098.....	WINS SERVER IP
YES.....	TIMEOUT CHECKING
300.....	TIMEOUT VALUE
000.....	ARP INTERVAL
9100.....	BASE RAW PORT
Wireless	
ALL.....	IP PROTOCOL
000.000.000.000.....	IP ADDRESS
255.255.255.000.....	SUBNET
000.000.000.000.....	GATEWAY
000.000.000.000.....	WINS SERVER IP
YES.....	TIMEOUT CHECKING
300.....	TIMEOUT VALUE
000.....	ARP INTERVAL
9100.....	BASE RAW PORT
NOT INSERTED.....	CARD INSERTED
H.....	CARD MFG ID
H.....	CARD PRODUCT ID
00:00:00:00:00:00.....	MAC ADDRESS
YES.....	DRIVER INSTALLED
INFRASTRUCTURE.....	OPERATING MODE
123456.....	ESSID
100.....	TX POWER
ALL.....	CURRENT TX RATE
OPEN.....	WEP TYPE
NONE.....	WLAN SECURITY
1.....	WEP INDEX
000.....	POOR SIGNAL
LONG.....	PREAMBLE
NO.....	ASSOCIATED
ON.....	PULSE ENABLED
15.....	PULSE RATE
OFF.....	INTL MODE
not available.....	REGION CODE
no region code.....	COUNTRY CODE
0x7FF.....	CHANNEL MASK
FIRMWARE IN THIS PRINTER IS COPYRIGHTED	

PAUSE Self Test

This self test can be used to provide the test labels required when making adjustments to the printer's mechanical assemblies or to determine if any printhead elements are not working. [Figure 22](#) shows a sample printout.

To perform a PAUSE self test, complete these steps:

1. Turn off (O) the printer.
2. Press and hold **PAUSE** while turning on (I) the printer. Hold **PAUSE** until the first control panel light turns off.
 - The initial self test prints 15 labels at the printer's slowest speed, and then automatically pauses the printer. Each time **PAUSE** is pressed, an additional 15 labels print. [Figure 22](#) shows a sample of the labels.

Figure 22 • PAUSE Test Label

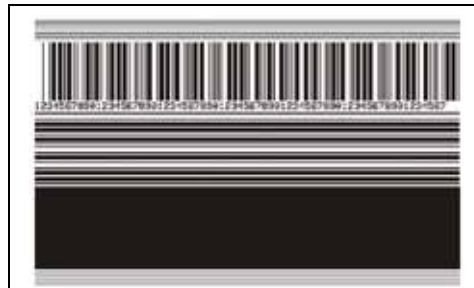

- While the printer is paused, pressing **CANCEL** alters the self test. Each time **PAUSE** is pressed, 15 labels print at 6 in. (152 mm) per second.
 - While the printer is paused, pressing **CANCEL** again alters the self test a second time. Each time **PAUSE** is pressed, 50 labels print at the printer's slowest speed
 - While the printer is paused, pressing **CANCEL** again alters the self test a third time. Each time **PAUSE** is pressed, 50 labels print at 6 in. (152 mm) per second.
 - While the printer is paused, pressing **CANCEL** again alters the self test a fourth time. Each time **PAUSE** is pressed, 15 labels print at the printer's maximum speed.
3. To exit this self test at any time, press and hold **CANCEL**.

FEED Self Test

Different types of media may require different darkness settings. This section contains a simple but effective method for determining the ideal darkness for printing bar codes that are within specifications.

During the FEED self test, labels are printed at different darkness settings at two different print speeds. The relative darkness and the print speed are printed on each label. The bar codes on these labels may be ANSI-graded to check print quality.

During this test, one set of labels is printed at 2 ips, and another set is printed at 6 ips. The darkness value starts at three settings lower than the printer's current darkness value (relative darkness of -3) and increase until the darkness is three settings higher than the current darkness value (relative darkness of +3).

The speed at which labels are printed during this print quality test depends on the dot density of the printhead.

- 300 dpi printers: 7 labels are printed at the 2 ips and 8 ips print speeds.
- 203 dpi printers: 7 labels are printed at the 2 ips and 12 ips print speeds.

To perform a FEED self test, complete these steps:

1. Print a configuration label to show the printer's current settings.
2. Turn off (O) the printer.
3. Press and hold **FEED** while turning on (I) the printer. Hold **FEED** until the first control panel light turns off.

The printer prints a series of labels (Figure 23) at various speeds and at darkness settings higher and lower than the darkness value shown on the configuration label.

Figure 23 • FEED Test Label



- See [Figure 24](#) and [Table 18](#). Inspect the test labels and determine which one has the best print quality for your application. If you have a bar code verifier, use it to measure bars/spaces and calculate the print contrast. If you do not have a bar code verifier, use your eyes or the system scanner to choose the optimal darkness setting based on the labels printed in this self test.

Figure 24 • Bar Code Darkness Comparison

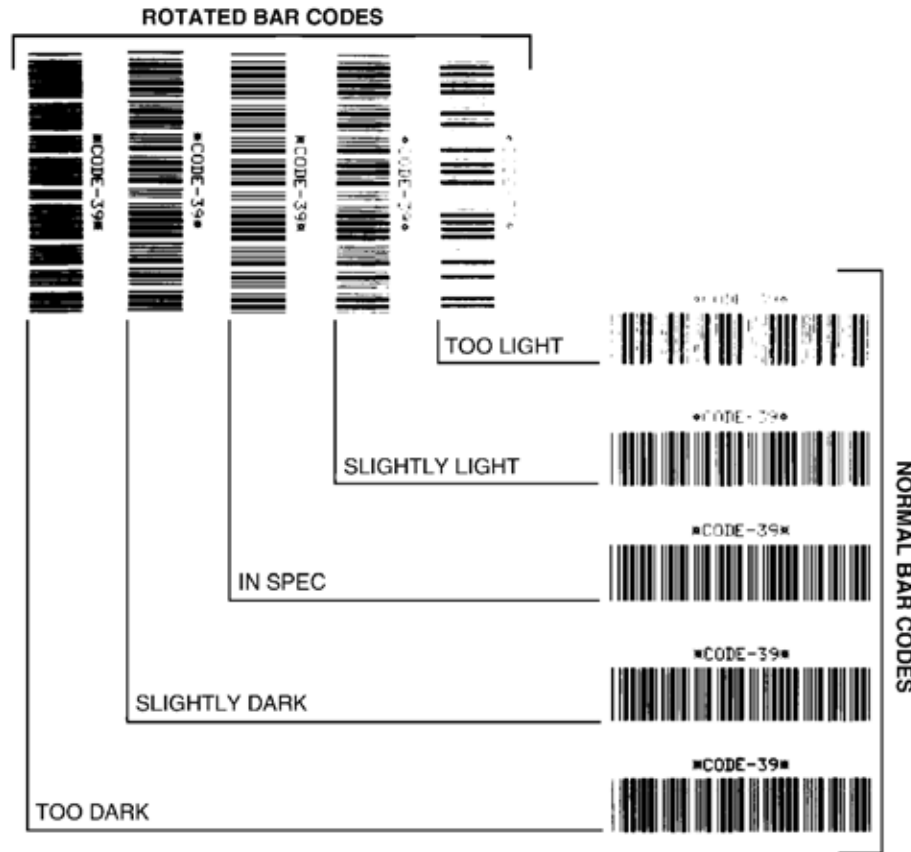

Table 18 • Judging Bar Code Quality

Print Quality	Description
Too dark	<p>Labels that are too dark are fairly obvious. They may be readable but not “in-spec.”</p> <ul style="list-style-type: none"> The normal bar code bars increase in size. The openings in small alphanumeric characters may fill in with ink. Rotated bar code bars and spaces run together.
Slightly dark	<p>Slightly dark labels are not as obvious.</p> <ul style="list-style-type: none"> The normal bar code will be “in-spec.” Small character alpha numerics will be bold and could be slightly filled in. The rotated bar code spaces are small when compared to the “in-spec” code, possibly making the code unreadable.

Table 18 • Judging Bar Code Quality (Continued)

Print Quality	Description
“In-spec”	<p>The “in-spec” bar code can only be confirmed by a verifier, but it should exhibit some visible characteristics.</p> <ul style="list-style-type: none"> • The normal bar code will have complete, even bars and clear, distinct spaces. • The rotated bar code will have complete, even bars and clear, distinct spaces. Although it may not look as good as a slightly dark bar code, the bar code will be “in-spec.” • In both normal and rotated styles, small alphanumeric characters look complete.
Slightly light	<p>Slightly light labels are, in some cases, preferred to slightly dark ones for “in-spec” bar codes.</p> <ul style="list-style-type: none"> • Both normal and rotated bar codes will be in spec, but small alphanumeric characters may not be complete.
Too light	<p>Labels that are too light are obvious.</p> <ul style="list-style-type: none"> • Both normal and rotated bar codes have incomplete bars and spaces. • Small alphanumeric characters are unreadable.

5. Note the relative darkness value and the print speed printed on the best test label.
6. Add or subtract the relative darkness value from the darkness value specified on the configuration label. The resulting numeric value is the best darkness value for that specific label/ribbon combination and print speed.
7. If necessary, change the darkness value to the darkness value on the best test label.
8. If necessary, change the print speed to the same speed as on the best test label.

FEED + PAUSE Self Test

Performing this self test resets the printer configuration to the factory default values. Perform a sensor calibration after this self test. (See [Calibrate the Ribbon and Media Sensors on page 122.](#))

Performing this self test temporarily resets the printer configuration to the factory default values. These values are active only until power is turned off unless you save them permanently in memory. If the factory default values are permanently saved, a media calibration procedure must be performed, and you must reset the head resistance value and the applicator port setting to their required values.

To perform a FEED and PAUSE self test, complete these steps:

1. Turn off (O) the printer.
2. Press and hold **FEED + PAUSE** while turning on (I) the printer.
3. Hold **FEED + PAUSE** until the first control panel light turns off.

The printer configuration is reset to the factory default values. No labels print at the end of this test.

CANCEL + PAUSE Self Test

Performing this self test resets the network configuration to the factory default values.

Performing this self test temporarily resets the printer configuration to the factory default values. These values are active only until power is turned off unless you save them permanently in memory. If the factory default values are permanently saved, a media calibration procedure must be performed, and you must reset the head resistance value and the applicator port setting to their required values.

To perform a CANCEL and PAUSE self test, complete these steps:

1. Turn off (O) the printer.
2. Press and hold **CANCEL + PAUSE** while turning on (I) the printer.
3. Hold **CANCEL + PAUSE** until the first control panel light turns off.

The printer's network configuration is reset to the factory default values. No labels print at the end of this test.

Communication Diagnostics Test

The communication diagnostics test is a troubleshooting tool for checking the interconnection between the printer and the host computer. When the printer is in diagnostics mode, it prints all data received from the host computer as straight ASCII characters with the hex values below the ASCII text. The printer prints all characters received, including control codes such as CR (carriage return). [Figure 25](#) shows a typical test label from this test.



Note • The test label prints upside-down.

Figure 25 • Communications Diagnostics Test Label



To use communications diagnostics mode, complete these steps:

1. Set the print width equal to or less than the label width being used for the test. See [Print Width on page 96](#) for more information.
2. Set the DIAGNOSTICS MODE option to ENABLED. For methods, see [Communication Diagnostics Mode on page 106](#).

The printer enters diagnostics mode and prints any data received from the host computer on a test label

3. Check the test label for error codes. For any errors, check that your communication parameters are correct.

Errors show on the test label as follows:

- FE indicates a framing error.
- OE indicates an overrun error.
- PE indicates a parity error.
- NE indicates noise.

4. Turn the printer off (O) and then back on (I) to exit this self test and return to normal operation.

Sensor Profile

Use the sensor profile image (which will extend across several actual labels or tags) to troubleshoot the following situations:

- The printer experiences difficulty in determining gaps (web) between labels.
- The printer incorrectly identifies preprinted areas on a label as gaps (web).
- The printer cannot detect ribbon.

With the printer in the Ready state, print a sensor profile in one of these ways:

Using the buttons on the control panel	<ol style="list-style-type: none"> Turn off (O) the printer. Press and hold FEED + CANCEL while turning on (I) the printer. Hold FEED + CANCEL until the first control panel light turns off.
Using ZPL	<ol style="list-style-type: none"> Send the ~JG command to the printer. See the <i>Zebra Programming Guide</i> for more information about this command.
ZT230 printer only	<ol style="list-style-type: none"> On the control panel display, navigate to the following item under the SENSORS menu. See <i>Idle Display, Home Menu, and User Menus on page 17</i> for information about using the control panel and accessing the menus. <div data-bbox="846 1024 1297 1276" data-label="Image"> <p>The image shows a rectangular display screen with a black border. At the top, it says 'PRINT INFORMATION'. Below that, there is a downward-pointing triangle followed by 'SENSOR PROFILE' and an upward-pointing triangle. At the bottom of the screen, there is a horizontal line. Below the line, on the left, is a house-shaped icon (home button), and on the right, the word 'PRINT' is displayed in a black box.</p> </div> Press RIGHT SELECT to select PRINT.

Compare your results to the examples shown in this section. If the sensitivity of the sensors must be adjusted, calibrate the printer (see *Calibrate the Ribbon and Media Sensors on page 122*).

Ribbon Sensor Profile (Figure 26) The line labeled RIBBON (1) on the sensor profile indicates the ribbon sensor readings. The ribbon sensor threshold setting is indicated by OUT (2). If the ribbon readings are below the threshold value, the printer does not acknowledge that ribbon is loaded.

Figure 26 • Sensor Profile (Ribbon Section)

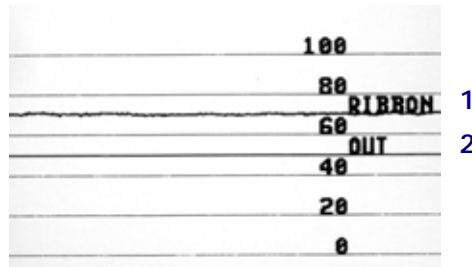

Media Sensor Profile (Figure 27) The line labeled MEDIA (1) on the sensor profile indicates the media sensor readings. The media sensor threshold settings is indicated by WEB (2). The media out threshold is indicated by OUT (3). The downward spikes (4) indicate gaps between labels (the web), and the lines between the spikes (5) indicate where labels are located.

If you compare the sensor profile printout to a length of your media, the spikes should be the same distance apart as the gaps on the media. If the distances are not the same, the printer may be having difficulty determining where the gaps are located.

Figure 27 • Sensor Profile (Media Section)

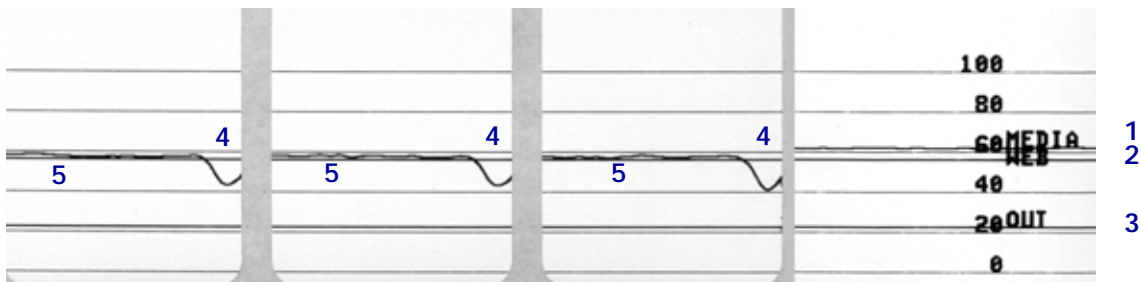

Specifications

This section lists general printer specifications, printing specifications, ribbon specifications, and media specifications.

Contents

General Specifications	176
Printing Specifications	180
Ribbon Specifications.....	180
Media Specifications	181

General Specifications

Model		ZT230	ZT220	ZT210
Height		10.9 in. (277 mm)	11.0 in. (280 mm)	10.9 in. (277 mm)
Width		9.5 in. (242 mm)	9.4 in. (239 mm)	9.5 in. (242 mm)
Depth		17 in. (432 mm)	17 in. (432 mm)	17 in. (432 mm)
Weight		20 lb (9.1 kg)	17 lb (7.8 kg)	20 lb (9.1 kg)
Electrical		100–240 VAC, 47-63 Hz, 3 Amps (100 W)		
Temperature	Operating	Thermal Transfer: 41° to 104°F (5° to 40°C) Direct Thermal: 32° to 104°F (0° to 40°C)		
	Storage	–40° to 140°F (–40° to 60°C)		
Relative Humidity	Operating	20% to 85%, non-condensing		
	Storage	5% to 85%, non-condensing		
Communication Interface Specifications	Standard	<p>USB 1.1 Data Interface Limitations and Requirements</p> <ul style="list-style-type: none"> Maximum cable length of 16.4 ft (5 m). <p>Connections and Configuration</p> <p>No additional configuration is necessary.</p> <ul style="list-style-type: none"> Optional interface (one of the following): <ul style="list-style-type: none"> 8-bit parallel data interface; nibble mode compliant 802.11a/b/g/n wireless card support 		
		<p>RS-232/CCITT V.24 Serial Data Interface</p> <ul style="list-style-type: none"> 2400 to 115000 baud parity, bits/character 7 or 8 data bit XON-XOFF, RTS/CTS, or DTR/DSR handshake protocol required 750mA at 5 V from pins 1 and 9 <p>Limitations and Requirements</p> <ul style="list-style-type: none"> You must use a null-modem cable to connect to the printer or a null-modem adaptor if using a standard modem cable. Maximum cable length of 50 ft (15.24 m). You may need to change printer parameters to match the host computer. <p>Connections and Configuration</p> <p>The baud rate, number of data and stop bits, the parity, and the XON/XOFF or DTR control must match those of the host computer.</p>		
		(Continued on next page.)		

Model		ZT230	ZT220	ZT210
Communication Interfaces (continued)	Optional (only one of the following may be installed at a time)	Wired 10/100 Internal Ethernet Print Server Limitations and Requirements <ul style="list-style-type: none"> • The printer must be configured to use your LAN. • A second wired print server can be installed in the bottom option slot. Connections and Configuration Refer to the <i>ZebraNet Wired and Wireless Print Servers User Guide</i> for configuration instructions. A copy of this manual is available at http://www.zebra.com/manuals .		
		Wireless print server 802.11 b <ul style="list-style-type: none"> • 2.4GHz • DSSS (DBPSK, DQPSK and CCK) • RF power 10 mW (ZebraNet b/g Print Server) 802.11 g <ul style="list-style-type: none"> • 2.4GHz • OFDM (16-QAM and 64-QAM with BPSK and QPSK) • RF power 10 mW (ZebraNet b/g Print Server) Limitations and Requirements <ul style="list-style-type: none"> • Can print to the printer from any computer on your Wireless Local Area Network (WLAN). • Can communicate with the printer through the printer's web pages. • The printer must be configured to use your WLAN. • Can be installed only in the top option slot. Configuration Refer to the <i>ZebraNet Wired and Wireless Print Servers User Guide</i> for configuration instructions. A copy of this manual is available at http://www.zebra.com/manuals .		
		8-bit Parallel data interface nibble mode compliant Limitations and Requirements <ul style="list-style-type: none"> • Maximum cable length of 10 ft (3 m). • Recommended cable length of 6 ft (1.83 m). • No printer parameter changes required to match the host computer. • Can be installed in either the top or bottom option slot. Connections and Configuration No additional configuration is necessary.		
		Firmware <ul style="list-style-type: none"> • ZPL II® • Zebra Global Printing Solution • EPL™ (optional, 203 dpi models only) • WebView and Alert • ZBI 2.0 (optional) 		

Power Cord Specifications



Caution • For personnel and equipment safety, always use an approved three-conductor power cord specific to the region or country intended for installation. This cord must use an IEC 320 female connector and the appropriate region-specific, three-conductor grounded plug configuration.

Depending on how your printer was ordered, a power cord may or may not be included. If one is not included or if the one included is not suitable for your requirements, see <X-refBlue>Figure 28 and refer to the following guidelines:

- The overall cord length must be less than 9.8 ft. (3 m).
- The cord must be rated for at least 10 A, 250 V.
- The chassis ground (earth) **must** be connected to ensure safety and reduce electromagnetic interference.

Figure 28 • Power Cord Specifications

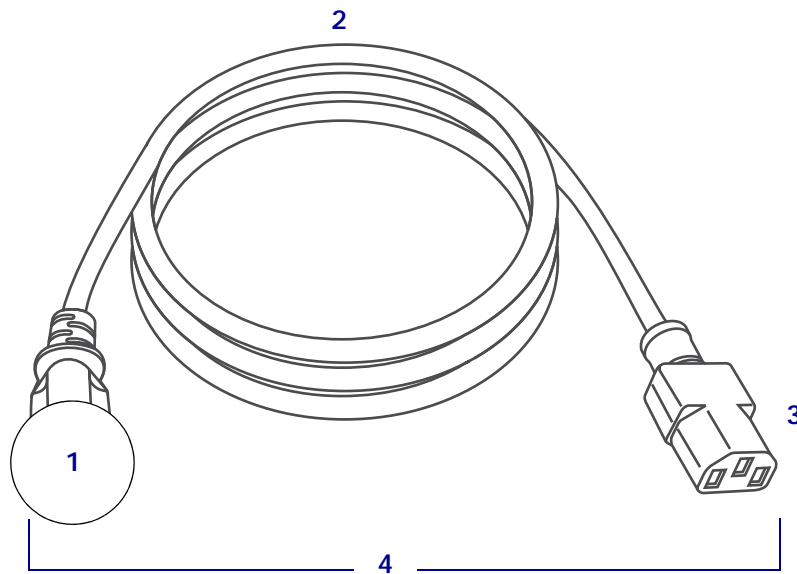

1	AC power plug for your country—This should bear the certification mark of at least one of the known international safety organizations (<X-refBlue>Figure 29).
2	3-conductor HAR cable or other cable approved for your country.
3	IEC 320 connector—This should bear the certification mark of at least one of the known international safety organizations (<X-refBlue>Figure 29).
4	Length \leq 9.8 ft. (3 m). Rating 10 Amp, 250 VAC.

Figure 29 • International Safety Organization Certification Symbols



Printing Specifications

Print resolution		203 dpi (dots per inch) (8 dots/mm)
		300 dpi (12 dots/mm)
Dot size (nominal) (width x length)	203 dpi	0.0043 in. x 0.0052 in. (0.110 mm x 0.132 mm)
	300 dpi	0.0043 in. x 0.0052 in. (0.110 mm x 0.132 mm)
Maximum print width	203 dpi	4.25 in. (108 mm)
	300 dpi	4.16 in. (105.7 mm)
Bar code modulus (X) dimension	203 dpi	5 mil to 50 mil
	300 dpi	3.3 mill to 33 mil
Programmable constant print speeds	203 dpi and 300 dpi	Per second: <ul style="list-style-type: none"> • 2 in. (51 mm) • 3 in. (76 mm) • 4 in. (102 mm) • 5 in. (127 mm) • 6 in. (152 mm)

Ribbon Specifications

Model		ZT230	ZT220	ZT210
Ribbon width*	Minimum	> 2 in.** (>51 mm**)		
	Maximum	4.3 in. (110 mm)		
Maximum ribbon length		1476 ft (450 m)	984 ft (300 m)	984 ft (300 m)
		3:1 media to ribbon roll ratio	2:1 media to ribbon roll ratio	2:1 media to ribbon roll ratio
Ribbon core inside diameter		1 in. (25 mm)		

* Zebra recommends using ribbon that is at least as wide as the media to protect the printhead from wear.

** Depending on your application, you may be able to use ribbon narrower than 2 in. (51 mm), as long as the ribbon is wider than the media being used. To use a narrower ribbon, test the ribbon's performance with your media to assure that you get the desired results.

Media Specifications

Label length	Minimum (Tear-Off)	0.7 in. (17.8 mm)
	Minimum (Peel-Off)	0.5 in (12.7 mm)
	Minimum (Liner Take-Up)	0.8 in (20.3 mm)
	Minimum (Cutter)	1.0 in. (25.4 mm)
	Maximum	39 in. (991 mm)
Label width	Minimum	0.75 in. (19 mm)
	Maximum	4.5 in. (114 mm)
Total thickness (includes liner, if any)	Minimum	0.003 in (0.076 mm)
	Maximum	0.010 in. (0.25 mm)
Maximum roll outside diameter	3-in. (76 mm) core	8 in. (203 mm)
	1-in. (25 mm) core	6 in. (152 mm)
Inter-label gap	Minimum	0.079 in. (2 mm)
	Preferred	0.118 in. (3 mm)
	Maximum	0.157 in. (4 mm)
Ticket/tag notch size (width x length)		0.25 in. x 0.12 in. (6 mm x 3 mm)
Hole diameter		0.125 in. (3.18 mm)
Notch or hole position (centered from inner media edge)	Minimum	0.15 in. (3.8 mm)
	Maximum	2.25 in. (57 mm)
Density, in Optical Density Units (ODU) (black mark)		> 1.0 ODU
Maximum media density		≤ 0.5 ODU
Transmissive media sensor (fixed position)		7/16 in. (11 mm) from inside edge



Notes • _____

Glossary

alphanumeric Indicating letters, numerals, and characters such as punctuation marks.

backfeed When the printer pulls the media and ribbon (if used) backward into the printer so that the beginning of the label to be printed is properly positioned behind the printhead. Backfeed occurs when operating the printer in Tear-Off and Applicator modes.

bar code A code by which alphanumeric characters can be represented by a series of adjacent stripes of different widths. Many different code schemes exist, such as the universal product code (UPC) or Code 39.

black mark A registration mark found on the underside of the print media that acts as a start-of-label indication for the printer. (See *non-continuous media*.)

calibration (of a printer) A process in which the printer determines some basic information needed to print accurately with a particular media and ribbon combination. To do this, the printer feeds some media and ribbon (if used) through the printer and senses whether to use the direct thermal or thermal transfer print method, and (if using non-continuous media) the length of individual labels or tags.

configuration The printer configuration is a group of operating parameters specific to the printer application. Some parameters are user selectable, while others are dependent on the installed options and mode of operation. Parameters may be switch selectable, control panel programmable, or downloaded as ZPL II commands. A configuration label listing all the current printer parameters may be printed for reference.

continuous media Label or tag-stock media that has no notch, gap, or web (media liner only) to separate the labels or tags. The media is one long piece of material.

core diameter The inside diameter of the cardboard core at the center of a roll of media or ribbon.

diagnostics Information about which printer functions are not working that is used for troubleshooting printer problems.

die-cut media A type of label stock that has individual labels stuck to a media liner. The labels may be either lined up against each other or separated by a small distance. Typically the material surrounding the labels has been removed. (See *non-continuous media*.)

direct thermal A printing method in which the printhead presses directly against the media. Heating the printhead elements causes a discoloration of the heat-sensitive coating on the media. By selectively heating the printhead elements as the media moves past, an image is printed onto the media. No ribbon is used with this printing method. Contrast this with *thermal transfer*.

direct thermal media Media that is coated with a substance that reacts to the application of direct heat from the printhead to produce an image.

dynamic RAM The memory devices used to store the label formats in electronic form while they are being printed. The amount of DRAM memory available in the printer determines the maximum size and number of label formats that can be printed. This is volatile memory that loses the stored information when power is turned off.

fanfold media Media that comes folded in a rectangular stack. Contrast this with *roll media*.

firmware This is the term used to specify the printer's operating program. This program is downloaded to the printer from a host computer and stored in FLASH memory. Each time the printer power is turned on, this operating program starts. This program controls when to feed the media forward or backward and when to print a dot on the label stock.

FLASH memory FLASH memory is non-volatile and maintains the stored information intact when power is off. This memory area is used to store the printer's operating program. In addition, this memory can be used to store optional printer fonts, graphic formats, and complete label formats.

Font A complete set of alphanumeric characters in one style of type. Examples include CG Times™, CG Triumvirate Bold Condensed™.

ips (inches-per-second) The speed at which the label or tag is printed. Many Zebra printers can print from 1 ips to 12 ips.

label An adhesive-backed piece of paper, plastic, or other material on which information is printed.

label backing (liner) The material on which labels are affixed during manufacture and which is discarded or recycled by the end-users.

light emitting diode (LED) Indicators of specific printer status conditions. Each LED is either off, on, or blinking depending on the feature being monitored.

liquid crystal display (LCD) The LCD is a back-lit display that provides the user with either operating status during normal operation or option menus when configuring the printer to a specific application.

media Material onto which data is printed by the printer. Types of media include: tag stock, die-cut labels, continuous labels (with and without media liner), non-continuous media, fanfold media, and roll media.

media sensor This sensor is located behind the printhead to detect the presence of media and, for non-continuous media, the position of the web, hole, or notch used to indicate the start of each label.

media supply hanger The stationary arm that supports the media roll.

non-continuous media Media that contains an indication of where one label/printed format ends and the next one begins. Examples are die-cut labels, notched tag-stock, and stock with black mark registration marks.

non-volatile memory Electronic memory that retains data even when the power to the printer is turned off.

notched media A type of tag stock containing a cutout area that can be sensed as a start-of-label indicator by the printer. This is typically a heavier, cardboard-like material that is either cut or torn away from the next tag. (See *non-continuous media*.)

peel-off A mode of operation in which the printer peels a printed label away from the backing and allows the user to remove it before another label is printed. Printing pauses until the label is removed.

print speed The speed at which printing occurs. For thermal transfer printers, this speed is expressed in terms of ips (inches per second).

printhead wear The degradation of the surface of the printhead and/or the print elements over time. Heat and abrasion can cause printhead wear. Therefore, to maximize the life of the printhead, use the lowest print darkness setting (sometimes called burn temperature or head temperature) and the lowest printhead pressure necessary to produce good print quality. In the thermal transfer printing method, use ribbon that is as wide or wider than the media to protect the printhead from the rough media surface.

registration Alignment of printing with respect to the top (vertical) or sides (horizontal) of a label or tag.

ribbon A band of material consisting of a base film coated with wax or resin “ink.” The inked side of the material is pressed by the printhead against the media. The ribbon transfers ink onto the media when heated by the small elements within the printhead. Zebra ribbons have a coating on the back that protects the printhead from wear.

ribbon wrinkle A wrinkling of the ribbon caused by improper alignment or improper printhead pressure. This wrinkle can cause voids in the print and/or the used ribbon to rewind unevenly. This condition should be corrected by performing adjustment procedures.

roll media Media that comes supplied rolled onto a core (usually cardboard). Contrast this with *fanfold media*.

supplies A general term for media and ribbon.

symbology The term generally used when referring to a bar code.

tag A type of media having no adhesive backing but featuring a hole or notch by which the tag can be hung on something. Tags are usually made of cardboard or other durable material.

tear-off A mode of operation in which the user tears the label or tag stock away from the remaining media by hand.

thermal transfer A printing method in which the printhead presses an ink or resin coated ribbon against the media. Heating the printhead elements causes the ink or resin to transfer onto the media. By selectively heating the printhead elements as the media and ribbon move past, an image is printed onto the media. Contrast this with *direct thermal*.

void A space on which printing should have occurred, but did not due to an error condition such as wrinkled ribbon or faulty print elements. A void can cause a printed bar code symbol to be read incorrectly or not at all.

Index

A

- active print server, 111
- adhesive test for ribbon coating, 22
- adjustments
 - display contrast, 101
 - label left position, 97
 - maximum label length, 99
 - print darkness, 93
 - print width, 96
 - printhead pressure, 127
 - ribbon spindle tension, 130
 - tear-off position, 95

B

- bar codes
 - bar code does not scan, 154
 - bar codes label, 100
 - darkness comparison during FEED self test, 167
- battery disposal, 148
- baud rate, 120
- black mark media
 - described, 19
 - selecting media type, 94
- broken ribbon, 155
- buttons on control panel, 13

C

- calibration
 - Auto Calibrate failed, 154
 - how to set as head-close action, 103
 - how to set as power-up action, 102
 - procedure, 122
 - SHORT CAL
 - how to set for head-close action, 103
 - how to set for power-up action, 102
 - ways to initiate, 105
- Canadian DOC compliance, 4
- CANCEL button
 - CANCEL self test, 165
 - ZT210 printer control panel, 14
 - ZT220 printer control panel, 14
 - ZT230 printer control panel, 13
- changing printer parameters, 18
- cleaning
 - cutter module, 144
 - exterior of printer, 135
 - media compartment, 135
 - peel-off assembly, 140
 - printhead and platen roller, 136
 - recommended cleaning schedule, 134
 - sensors, 135
- command character, 116
- command language, 115
- communication diagnostics mode
 - how to initiate, 106
 - overview, 171
- communication interfaces, 28
- communications problems, 161

- configuration label
 - print through Zebra Setup Utilities, 87
 - print using CANCEL self test, 165
 - various ways to print, 100
- conformity declaration, 3
- connecting printer to computer or network, 28
- continuous media
 - described, 20
 - selecting media type, 94
- control character, 116
- control panel
 - button function, 13
 - error messages, 157
 - location, 12
 - navigation, 15
- CUT ERROR message, 160
- Cutter mode
 - cleaning the cutter module, 144
 - CUT ERROR message, 160
 - description and media path, 64
 - how to select, 97

D

- darkness
 - adjustments, 93
 - print quality too light or too dark, 153
- data bits, 120
- data source
 - connections, 28
 - site selection considerations, 27
- declaration of conformity, 3
- default gateway, 110
- default reset, 104
- delimiter character, 117
- diagnostic mode
 - how to initiate, 106, 171
- diagnostics, 164
- Direct Thermal mode
 - media scratch test, 21
 - setting, 94
- display
 - contrast adjustment, 101
 - display language, 114
 - missing characters, 162
 - ZT230 printer control panel, 13
- display language
 - how to change from unfamiliar language, 162
- disposal of printer parts, 148
- driver installation, 28

E

- electronics cover, 12
- enable ZBI, 107
- error messages, 157
- ESSID, 112
- Ethernet
 - characteristics of a wired connection, 177
 - characteristics of wireless connection, 177
 - connecting the printer to a wired network, 49
 - connecting the printer to a wireless network, 56
- external view of printer, 12

F

- factory defaults, 104
- fanfold media
 - described, 20
 - loading, 71
- FCC compliance, 4
- FCC radiation exposure limits, 4
- feed a label
 - how to set as head-close action, 103
 - how to set as power-up action, 102
 - ZT210 printer, 14
 - ZT220 printer, 14
 - ZT230 printer, 13
- FEED button
 - FEED and PAUSE self test, 170
 - FEED self test, 167
 - ZT210 printer control panel, 14
 - ZT220 printer control panel, 14
 - ZT230 printer control panel, 13
- fonts label, 100
- formats label, 100

G

- gap/notch
 - illustrations, 19
 - selecting media type, 94
 - ways to select media sensor type, 118
- gateway, 110

H

- HEAD COLD message
 - cycling with other messages, 159
 - displaying alone, 160
- HEAD OPEN message, 157
- head-close action, 103
- Home menu, 17
- host handshake, 121

I

- idle display
 - accessing the Home menu from the Idle Display, 17
 - how to change what displays, 102
- images distorted on labels, 161
- images label, 100
- indicator lights
 - combined with error message on ZT230, 157
 - troubleshooting, 150
 - ZT210 printer control panel, 14
 - ZT220 printer control panel, 14
 - ZT230 printer control panel, 13
- initiate manual calibration, 105
- inspect for shipping damage, 26
- IP addresses, 109
- IP protocol, 111
- IP resolution
 - IP protocol, 111

L

- label length maximum, 99
- label sensor sensitivity, 118
- label shift, 97
- label width, 96
- labels did not print, 161
- labels not printing, 161
- language
 - how to change from unfamiliar language, 162
- languages supported on display, 114
- last saved settings, 104
- LCD contrast, 101
- LCD error messages, 157
- left position adjustment, 97
- LENGTH
 - how to set as head-close action, 103
 - how to set as power-up action, 102
- liability, 2
- Liner Take-Up mode
 - description and media path, 63
 - how to select, 97
- load defaults, 104
- location for printer, 27
- lubrication, 148

M

- MAC address, 112
- manual calibration
 - procedure, 122
 - ways to initiate, 105
- maximum label length, 99
- media
 - black mark, 19
 - continuous roll media, 20
 - fanfold, 20
 - non-continuous roll media, 19
 - perforated, 19
 - tag stock, 19
 - types of media, 19
 - web, 19
- media door, 12
- MEDIA OUT message, 157
- media scratch test, 21
- media sensor calibration
 - procedure, 122
 - ways to initiate, 105
- media sensor selection, 118
- media type selection, 94
- melted ribbon, 155
- menu structure, 18
- misregistration of labels, 153
- missing print on labels, 152

N

- navigation, 15
- network configuration label
 - print using CANCEL self test, 165
 - various ways to print, 100
- network defaults, 104
- network settings
 - load defaults, 104
 - reset network, 113
- NO MOTION
 - how to set as head-close action, 103
 - how to set as power-up action, 102
- non-continuous media
 - described, 19
 - problem with labels, 162
 - selecting media type, 94

O

- operating conditions, 27
- ordering replacement parts, 148
- OUT OF MEMORY message, 160

P

parallel port
 characteristics of parallel connection, 177
 connecting the printer to a computer, 41
 specifications, 176, 177

parity, 121

PAUSE button
 FEED and PAUSE self test, 170
 PAUSE self test, 166
 ZT210 printer control panel, 14
 ZT220 printer control panel, 14
 ZT230 printer control panel, 13

Peel-Off mode
 cleaning peel-off assembly, 140
 description and media path, 63
 how to select, 97

perforated media, 19

PH NOT AUTHENTICATED message, 159

power
 power cord specifications, 178
 site selection, 27

Power-On Self Test (POST), 164

power-up action, 102

print darkness setting, 93

PRINT HEAD OVERTEMP message, 159

print information
 how to print various printer information, 100

print method specification, 94

print mode selection, 97

print quality
 bar code does not scan, 154
 darkness comparison during FEED self test, 167
 printhead pressure adjustment, 127
 troubleshooting, 152

print server
 active print server user menu item, 111
 characteristics of wired connection, 177
 characteristics of wireless connection, 177
 default gateway, 110
 ESSID, 112
 IP addresses, 109
 IP protocol, 111
 MAC address, 112
 network configuration label, 100
 reset network settings, 113
 subnet mask, 109

print speed, 93

print width adjustment, 96

printer configuration label, 100

printer diagnostics, 164

printer driver, 28

printer locks up, 163

printer parameters, 18

printer settings
 darkness, 93
 label left position, 97
 maximum label length, 99
 media type, 94
 print method, 94
 print mode, 97
 print speed, 93
 print width, 96
 reprint mode, 98
 settings not taking effect, 162
 tear-off position, 95

printhead
 adjust printhead pressure, 127
 HEAD COLD message, 159
 how to clean, 136
 PH NOT AUTHENTICATED message, 159
 PRINT HEAD OVERTEMP message, 159
 THERMISTOR PREPLACE PRINTHEAD message, 159

Q

QR codes with error messages, 157

QuickHelp pages, 157

R

radiation exposure limits, 4

recycling printer parts, 148

reflective sensor selection, 118

registration loss during printing, 152

reinitialize printer server, 104

relative humidity
 operating, 27
 operating and storage, 176

reload last saved settings, 104

replacement parts, 148

report shipping damage, 26

reprint mode, 98

reset network settings, 113

reset printer to default values, 104

reset to defaults, 104

ribbon

- adhesive test, 22
- broken or melted ribbon, 155
- determining coated side, 21
- removal, 131
- ribbon not detected correctly, 156
- ribbon slips or does not advance, 155
- scratch test, 22
- setting Thermal Transfer mode, 94
- when to use, 21
- wrinkled ribbon, 155

RIBBON IN message, 158

RIBBON OUT message, 158

ribbon sensor calibration

- procedure, 122
- ways to initiate, 105

ribbon spindle tension adjustment, 130

roll media

- described, 19
- loading, 71

routine cleaning schedule, 134

run a ZBI program, 107

S

scratch test

- media type, 21
- ribbon coated side, 22

self tests, 164

- CANCEL, 165
- communication diagnostics, 171
- FEED, 167
- FEED and PAUSE, 170
- PAUSE, 166
- Power-On Self Test (POST), 164

sensor profile, 100

sensor type selection, 118

sensors

- interpreting sensor profile, 172
- transmissive sensor selection, 118

serial port

- characteristics of serial connection, 176
- connecting the printer to a computer, 41
- specifications, 176

setup

- install the printer driver, 28
- unpack the print engine, 26
- unpack the printer, 26

shipping

- report damage, 26
- reshipping the print engine, 26
- reshipping the printer, 26

SHORT CAL

- how to set as head-close action, 103
- how to set as power-up action, 102

site selection for printer, 27

smart phone

- QuickHelp pages, 157

smudge marks on labels, 153

spacing requirements, 27

stop a ZBI program, 108

storing the print engine, 26

storing the printer, 26

subnet mask, 109

surface for printer, 27

T

tag stock

- described, 19

take label sensor sensitivity, 119

Tear-Off mode

- description and media path, 62
- how to select, 97

tear-off position adjustment, 95

temperature

- operating, 27
- operating and storage, 176

tension setting for ribbon, 130

Thermal Transfer mode

- media scratch test, 21
- setting, 94

THERMISTOR REPLACE PRINTHEAD

- message, 159

transmissive sensor selection, 118

troubleshooting

- communications problems, 161
- diagnostic tests, 164
- error messages, 157
- indicator lights, 150
- print quality problems, 152
- ribbon problems, 155

types of media

- black mark media, 19
- continuous roll media, 20
- fanfold media, 20
- non-continuous roll media, 19
- perforated media, 19
- tag stock, 19
- web media, 19

U

- unpack the print engine, 26
- unpack the printer, 26
- USB port
 - characteristics of USB connection, 176
 - connecting the printer to a computer, 37
 - specifications, 176
- user menus, 18

V

- ventilation requirements, 27
- vertical drift
 - top-of-form position, 153

W

- web media
 - described, 19

- wired print server
 - characteristics, 177
 - specifications, 176, 177
- wireless print server
 - characteristics, 177
 - specifications, 176, 177
- wrinkled ribbon causes, 155

Z

- Zebra Basic Interpreter (ZBI)
 - enable, 107
 - run a ZBI program, 107
 - stop a ZBI program, 108
- Zebra Setup Utilities
 - installation, 28
 - print a test label, 87
- ZebraDesigner, 89
- ZPL mode, 117
- ZPL override, 115



Corporate Headquarters

Zebra Technologies Corporation
3 Overlook Point
Lincolnshire, IL 60069 USA
T: +1 847 634 6700
Toll-free +1 866 230 9494
F: +1 847 913 8766

<http://www.zebra.com>