

DS1200 Series

1200 Watts Distributed Power System

Total Power: 1000-1200 Watts
Input Voltage: 90-264 Vac
of Outputs: Main and Standby

Special Features

- Active power factor correction
- EN61000-3-2 harmonic compliance
- Active AC inrush control
- 1U X 2U form factor
- 21.71 W / in³
- +12 Vdc Output
- +3.3 Vdc stand-by (+5 Vdc stand-by)
- No minimum load required (main output only)
- Hot plug operation
- N + 1 redundant
- Internal OR'ing fets
- Active current sharing (10 - 100% load)
- I²C communication interface bus
- PMBus™ compliant
- EEPROM for FRU data
- Internal fan speed control
- INTEL, SSI Std. logic timing
- INTEL, SSI Std. FRU data format
- Full digital control
- 2 year warranty

Safety

UL/cUL 62368 (UL Recognized)
NEMKO+ CB Report EN60950
EN62368
CE Mark
China CCC



Product Descriptions

The DS1200-3 power supply features a very wide 90 to 264 Vac input voltage range and employ active power factor correction to minimize input harmonic current distortion and to ensure compliance with the international EN61000-3-2 standard – they have a power factor of 0.99 typical. The power supplies also feature active ac inrush control, to automatically limit inrush current at turn-on to 55 A maximum.

The power supply employs a new patent-pending ultra high efficiency conversion topology, together with an innovative power transformer and rectifier construction that further improves power density and reduces interconnect power losses. The power supply's main +12 Vdc payload output is digitally programmable over the range 11.4 to 12.6 Vdc, and users have a choice of standard I²C or advanced PMBus™ communications. The control software runs under Windows® on any standard PC, and uses a highly intuitive graphical user interface to simplify power supply set-up.

The DS1200-3 can deliver up to 98.4 A from its main +12 Vdc payload output, and up to 6 A from its +3.3 Vdc auxiliary output. The supply has a 1U x 2U form factor – it measures 10.9 x 3.3 inches, with a height of 1.6 inches – and has a power density of more than 21 watts per cubic inch. When fed with a 180 to 264 Vac input, the DS1200-3 can achieve a very high – 91 percent typical conversion efficiency at 50 percent full load.

Model Numbers

Standard	Output Voltage	Minimum Load	Maximum Load	Stand-By Supply	Air Flow Direction
DS1200-3	12.0Vdc	0A	98.4A	3.3Vdc@6A	Normal (DC Connector to Handle)
DS1200-3-002	12.0Vdc	0A	98.4A	5Vdc@4A	Normal (DC Connector to Handle)
DS1200-3-003	12.0Vdc	0A	98.4A	3.3Vdc@6A	Reversed (Handle to DC Connector)
DS1200-3-004	12.0Vdc	0A	98.4A	5Vdc@4A	Reversed (Handle to DC Connector)

Options

None

Electrical Specifications

Absolute Maximum Ratings

Stress in excess of those listed in the “Absolute Maximum Ratings” may cause permanent damage to the power supply. These are stress ratings only and functional operation of the unit is not implied at these or any other conditions above those given in the operational sections of this TRN. Exposure to any absolute maximum rated condition for extended periods may adversely affect the power supply’s reliability.

Table 1. Absolute Maximum Ratings:

Parameter	Model	Symbol	Min	Typ	Max	Unit
Input Voltage AC continuous operation	All models	$V_{IN,AC}$	90	-	264	Vac
Maximum Output Power (Main + Stand-by) $V_{IN,AC} \leq 180Vac$ $V_{IN,AC} > 180Vac$	All models	$P_{O,max}$	- -	- -	1000 1200	W W
Isolation Voltage Input to outputs Input to safety ground Outputs to safety ground	All models All models All models		- - -	- - -	2121 2121 50	Vdc Vdc Vdc
Ambient Operating Temperature	DS1200-3 DS1200-3-002 DS1200-3-003 DS1200-3-004	T_A	-10	-	+50 +70 ¹ +50 +50	°C °C °C °C
Storage Temperature	All models	T_{STG}	-40	-	+85	°C
Humidity (non-condensing) Operating Non-operating	All models All models		20 10	- -	90 95	% %
Altitude Operating Non-operating	All models All models		- -	- -	10,000 30,000	feet feet

Note 1 - With power derating (see page 22 power derating curve)

Input Specifications

Table 2. Input Specifications:

Parameter	Conditions	Symbol	Min	Typ	Max	Unit
Operating Input Voltage, AC		$V_{IN,AC}$	90	115/230	264	Vac
Input Vac Source Frequency		$f_{IN,AC}$	47	50/60	63	Hz
Maximum Input Current ($I_O = I_{O,max}$, $I_{SB} = I_{SB,Max}$)	$V_{IN,AC} = 90Vac$	$I_{IN,max}$	-	-	15	A
Standby Input Current ($V_O = Off$, $I_{SB} = 0A$)	$V_{IN,AC} = 90Vac$ $V_{IN,AC} = 180Vac$	$I_{IN,standby}$	-	-	400 300	mA
No Load Input Current ($V_O = On$, $I_O = 0A$, $I_{SB} = 0A$)	$V_{IN,AC} = 90Vac$ $V_{IN,AC} = 180Vac$	I_{IN,no_load}	-	-	800 450	mA
Harmonic Line Currents	All	THD	Per IEC1000-3-2			
Power Factor	All		-	0.99	-	
Startup Surge Current (Inrush) @ 25°C	$V_{IN,AC} = 264Vac$	$I_{IN,surge}$	-	-	40	A
Input Fuse	Internal, L and N 5x20mm, Quick Acting 16A, 250V		-	-	16	A
Leakage Current to earth ground	$V_{IN,AC} = 240Vac$ $f_{IN,AC} = 50/60\text{ Hz}$		-	-	1.4	mA
Operating Efficiency @ 25°C	$I_O = I_{O,max}$ $V_{IN,AC} = 100Vac$ $V_{IN,AC} = 200Vac$	η	85 89	- -	- -	% %
System Stability:						
Phase Margin			45	-	-	∅
Gain Margin			6	-	-	dB

Output Specifications

Table 3. Output Specifications:

Parameter	Condition	Symbol	Min	Typ	Max	Unit	
Output Regulation	All models	V_O	11.4	12.0	12.6	V	
	DS1200-3 DS1200-3-003	V_{SB}	3.13	3.30	3.47		
	DS1200-3-002 DS1200-3-004	V_{SB}	4.75	5.00	5.25		
Output Ripple, pk-pk	All models	V_O	-	-	120	mV_{PK-PK}	
	DS1200-3 DS1200-3-003	V_{SB}	-	-	50		
	DS1200-3-002 DS1200-3-004	V_{SB}	-	-	50		
Output Current	All models	I_O	0 0	-	81.7 98.4	A	
	DS1200-3 DS1200-3-003	I_{SB}	0.5	-	6.0		
	DS1200-3-002 DS1200-3-004	I_{SB}	0.5	-	4.0		
V_O Current Share Accuracy	40% to 100% I_O 10% to 40% I_O		- -	- -	5 20	% I_O	
V_O Minimum Current Share Loading			10	-	-	% $I_{O,max}$	
Number of Parallel Units ¹	Main Output Current Share connected		4	-	-		
V_O Load Capacitance	Start up		0	-	100	$\mu F/A$	
V_O Dynamic Response ²	Peak Deviation Settling Time	50% load change, slew rate = 1A/ μs	$\pm\%V_O$	-	-	5	%
			t_s	-	-	-	mSec
V_O Long Term Stability Max change over 24 hours	After thermal equilibrium (30 mins)	$\pm\%V_O$	-	-	0.2	%	

Note 1 - V_{SB} output do not use active current sharing. On paralleled units, maximum current on V_{SB} output rail should not exceed the current of one unit.

Note 2 - Recommend to test with 4700uF capacitive load at the V_O output and 470uF at V_{SB} output.

System Timing Specifications

Table 4. System Timing Specifications:

Label	Parameter	Min	Typ	Max	Unit
T1	Delay from AC being applied to V_{SB} being within regulation	-	-	1000	mSec
T2	Delay from AC being applied to output voltages being within regulation with PS_ON asserted low.	-	-	2000	mSec
T3	V_O rise time, 0V to V_O in regulation.	5	-	50	mSec
T4	Delay from output voltages within regulation limits to POWER GOOD asserted high.	100	-	1000	mSec
T5	Delay from loss of AC to de-assertion of POWER GOOD.	11	-	-	mSec
T6	Delay from POWER GOOD de-asserted to output voltages dropping out of regulation limits.	1			mSec
T7	Hold up time - time all output voltages, including V_{SB} , stay within regulation after loss of AC.	12	-	-	mSec
T8	Delay from loss of AC input to AC_OK going to high.	5	-	-	mSec
T9	Duration of POWER GOOD being in the de-asserted state during an off/on cycle using AC or the PS_ON signal	100	-	-	mSec
T10	Delay from PS_ON active to output voltages within regulation limits.	10	-	300	mSec
T11	Delay from PS_ON deactive to POWER GOOD de-asserted low.	-	-	50	mSec

System Timing Specifications

Figure 1. System Timing Diagram:

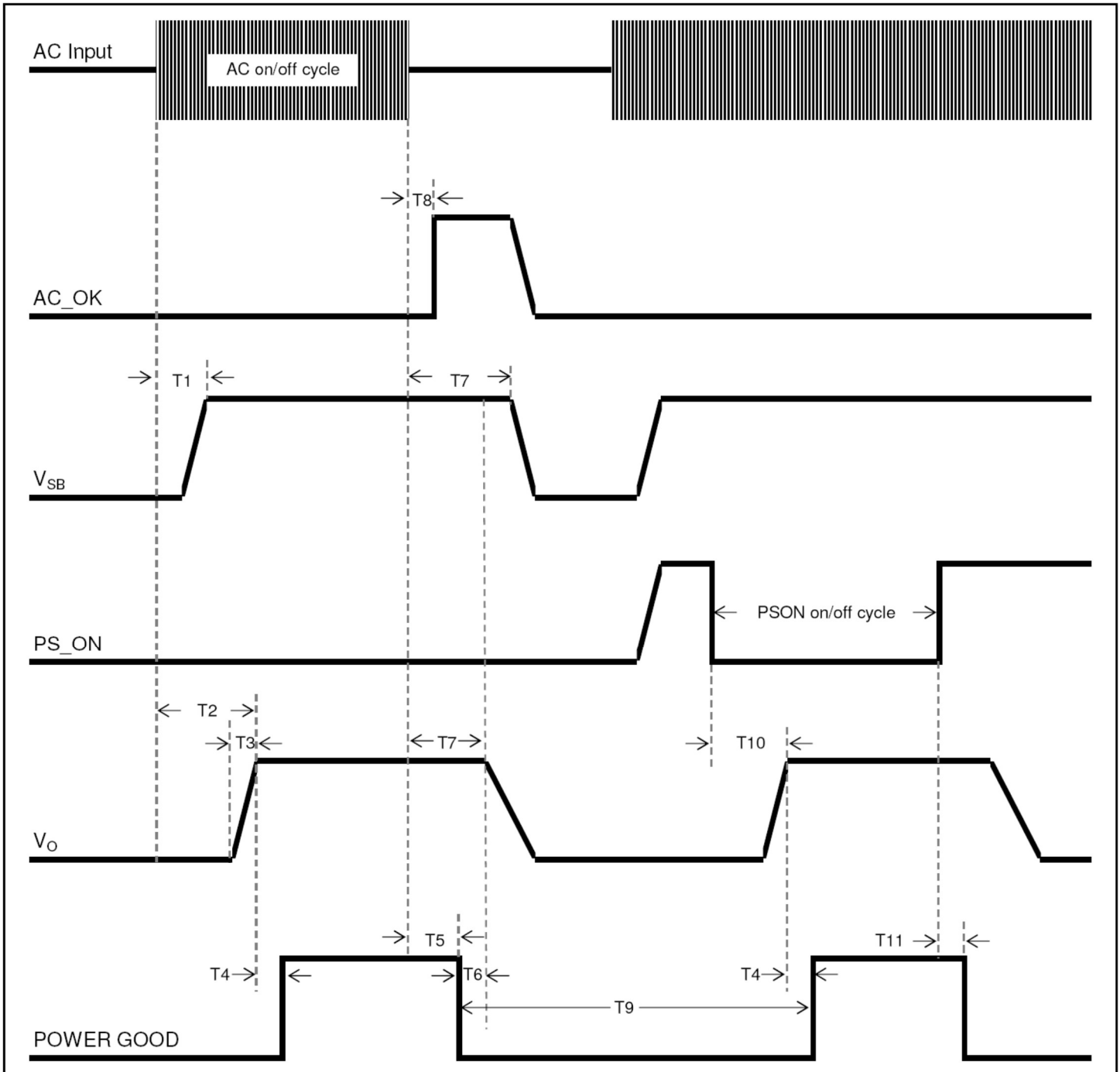

DS1200-3 Performance Curves

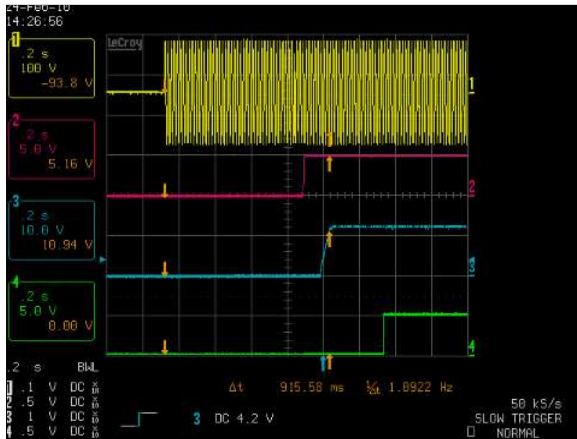

Figure 1: DS1200-3 Turn-on delay via AC mains – $V_{IN} = 90\text{Vac}$

Ch 1: AC Mains Ch 2: V_{SB} Ch 3: V_O Ch 4: POWER GOOD

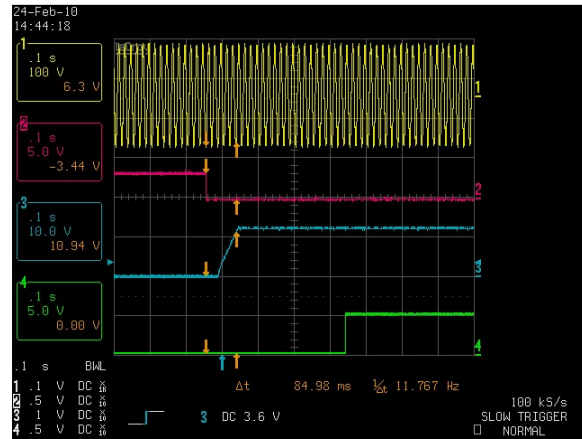

Figure 2: DS1200-3 Turn-on delay via PS_ON – $V_{IN} = 90\text{Vac}$

Ch 1: AC Mains Ch 2: PS_ON Ch 3: V_O Ch 4: POWER GOOD

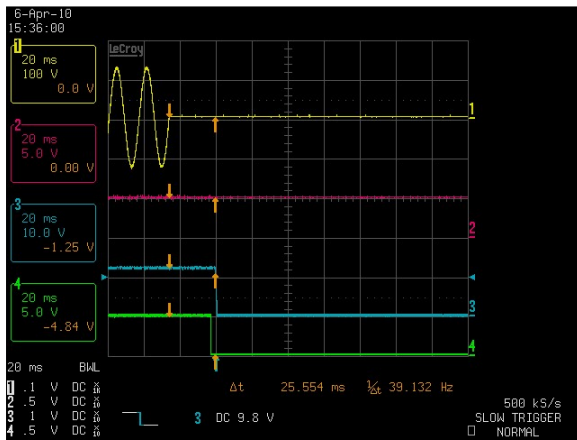

Figure 3: DS1200-3 Hold-up Time – $V_{IN} = 90\text{Vac} / 63\text{Hz} / 0^\circ$
Full Load: $I_O = 81.7\text{A}$, $I_{SB} = 4\text{A} (5\text{V})$

Ch 1: AC Mains Ch 2: V_{SB} Ch 3: V_O Ch 4: POWER GOOD

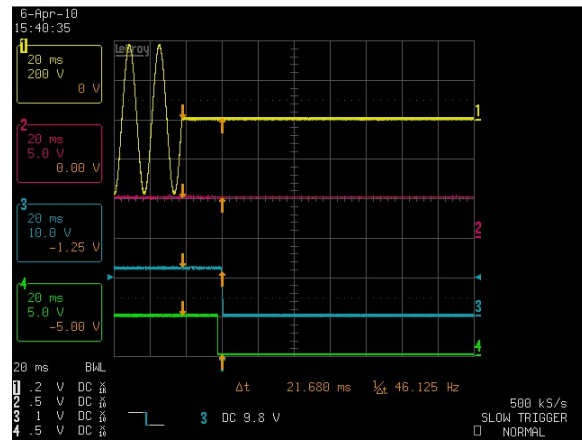

Figure 4: DS1200-3 Hold-up time – $V_{IN} = 264\text{Vac} / 47\text{Hz} / 0^\circ$
Full Load: $I_O = 81.7\text{A}$, $I_{SB} = 4\text{A} (5\text{V})$

Ch 1: AC Mains Ch 2: V_{SB} Ch 3: V_O Ch 4: POWER GOOD

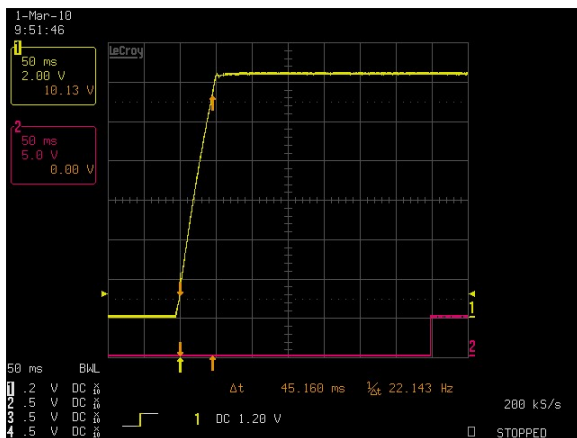

Figure 5: DS1200-3 Output Voltage Startup Characteristic – $V_{IN} = 90\text{Vac}$
Full Load: $I_O = 81.7\text{A}$, $I_{SB} = 4\text{A} (5\text{V})$

Ch 1: V_O Ch 2: POWER GOOD

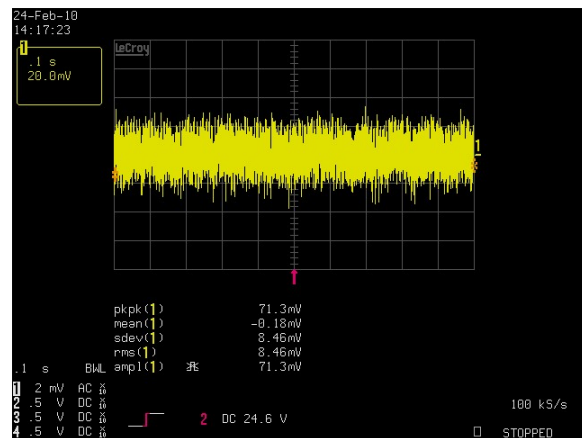

Figure 6: DS1200-3 Ripple and Noise Measurement – $V_{IN} = 90\text{Vac}$
Full Load: $I_O = 81.7\text{A}$, $I_{SB} = 4\text{A} (5\text{V})$

Ch 1: V_O

DS1200-3 Performance Curves

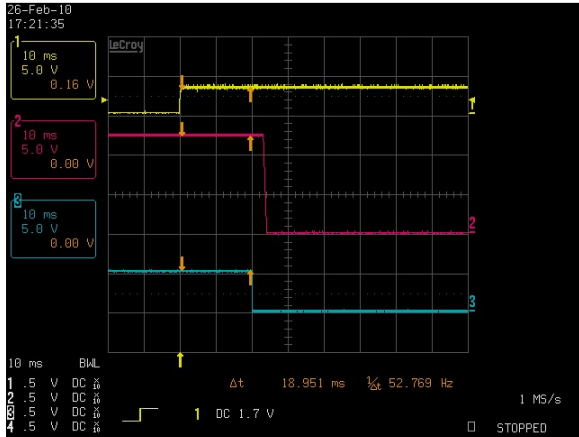

Figure 7: DS1200-3 Turn Off Characteristic via PS_ON
Full Load: $I_o = 81.7A$, $I_{SB} = 4A$ (5V)
Ch 1: PS_ON Ch 2: V_o Ch 3: POWER GOOD

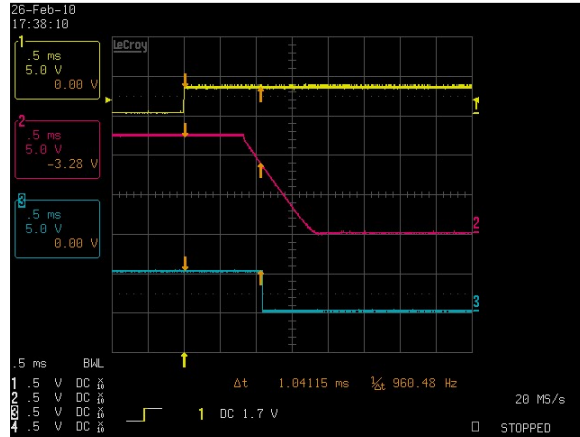

Figure 8: DS1200-3 Turn Off Characteristic via PS_INHIBIT
Full Load: $I_o = 81.7A$, $I_{SB} = 4A$ (5V)
Ch 1: PS_INHIBIT Ch 2: V_o Ch 3: POWER GOOD

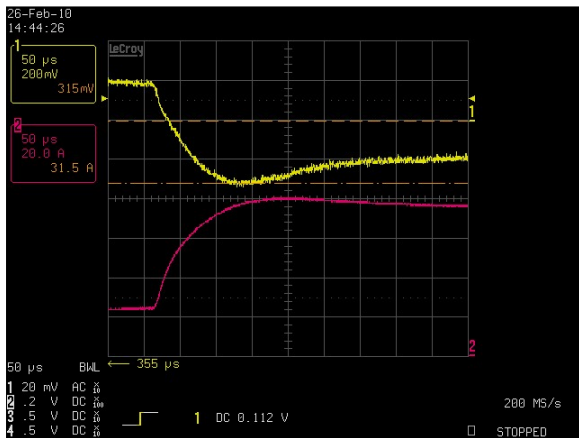

Figure 9: DS1200-3 Transient Response – V_o Deviation (low to high)
25% to 75% load change, $1A/\mu S$ slew rate, $V_{IN} = 230Vac$
Ch 1: V_o Ch 2: I_o

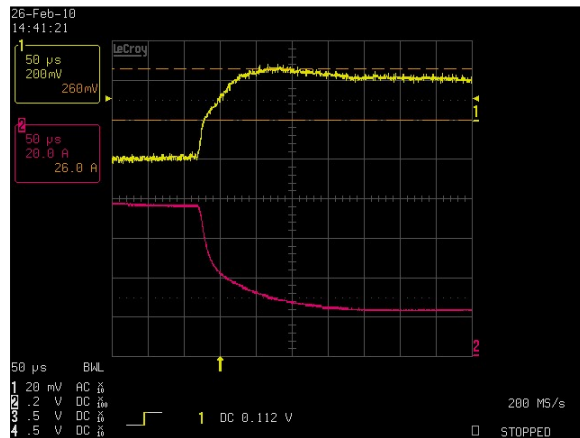

Figure 10: DS1200-3 Transient Response – V_o Deviation (high to low)
75% to 25% load change, $1A/\mu S$ slew rate, $V_{IN} = 230Vac$
Ch 1: V_o Ch 2: I_o

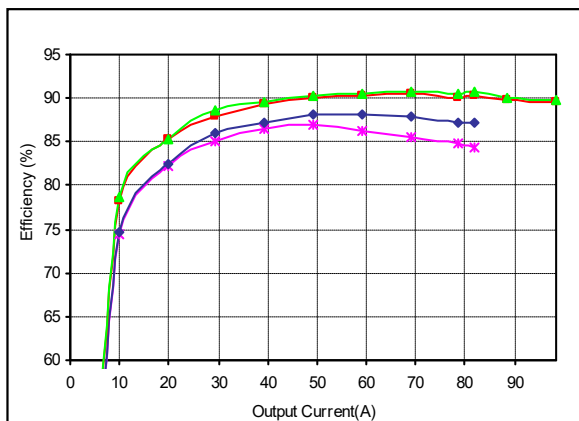

Figure 11: DS1200-3 Efficiency Curves @ 25 degC
—●— 80 Vac —■— 115 Vac —▲— 230 Vac —◆— 264 Vac
Loading: $I_o = 81.7A = 10\%$ increment to 98.4A, $I_{SB} = 0A$ (5V)

Protection Function Specification

Input Fusing

DS1200-3 series is equipped with an internal non user serviceable 16A High Rupturing Capacity (HRC) 250 Vac fuse to IEC 127 for fault protection in both the L1 and L2 lines input.

Over Voltage / Under Voltage Protection (OVP / UVP)

The power supply latches off during output overvoltage with the AC line recycled to reset the latch.

OVP

Parameter	Min	Nom	Max	Unit
V _O Output Overvoltage	13.2	/	14.4	V
3.3V Standby Output Overvoltage	3.76	/	4.30	V
5V Standby Output Overvoltage	5.75	/	6.50	V

UVP

Parameter	Min	Nom	Max	Unit
V _O Output Undervoltage	9.0	/	10.8	V

Over Current Protection (OCP)

DS1200-3 series includes internal current limit circuitry to prevent damage in the event of overload or short circuit. Recovery is automatic when the overload is removed, if the overload lasts for 1 second or less, and if it is less than or equal to 150% of rated load. If the overload is > 150% of rated load, the power supply will latch off immediately. In addition, if the overload fault is presented for longer than 1 second, the power supply will also latch off, requiring AC power or PS_ON recycling to restart the power supply.

Parameter	Input Voltage	Min	Nom	Max	Unit
V _O Output Overcurrent	180-264 Vac	118	/	147.6	A
	90-179 Vac	98	/	122.4	A
3.3V Standby Output Overcurrent	90-264 Vac	6.6	/	9	A
5V Standby Output Overcurrent	90-264 Vac	4.4	/	6	A

Short Circuit Protection (SCP)

The DS1200 power supply will withstand a continuous short circuit with no permanent damage, applied to its main output during start-up or while running.. A short is defined as impedance less than 0.1 ohms.

When the standby output V_{SB} is shorted the output will go into “hiccup mode”. When the V_{SB} attempts to restart, the maximum peak current from the V_{SB} output will be less than 9.0A peak (3.3V) or 6.6A (5.0V). The maximum average current, taking into account the “hiccup” duty cycle, is less than 4.9A.

Over Temperature Protection (OTP)

The power supply is internally protected against over temperature conditions. When the OT circuit is activated, the power supply will latch off, requiring AC power or PS_ON recycling to restart the power supply.

Mechanical Specifications

Mechanical Outlines (Unit:mm)

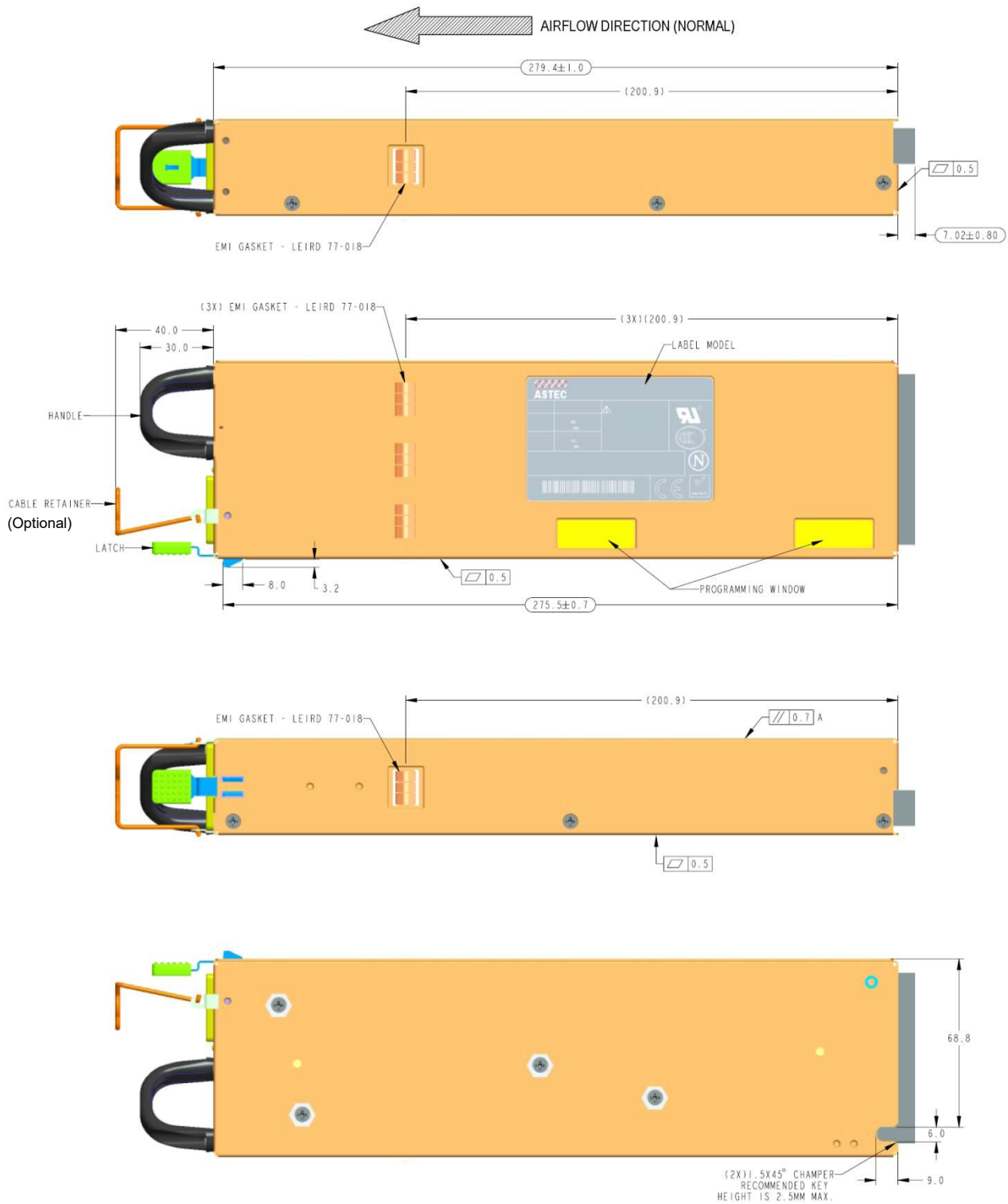

Connector Definitions

AC Input Connector

- Pin 1 – L1
- Pin 2 – L2
- Pin 3 – Earth Ground

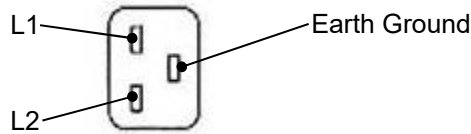

Output Connector – Power Blades

- PB1 – Main Output Return
- PB2 – Main Output Return
- PB3 – Main Output Return
- PB4 – + Main Output (V_O)
- PB5 – + Main Output (V_O)
- PB6 – + Main Output (V_O)

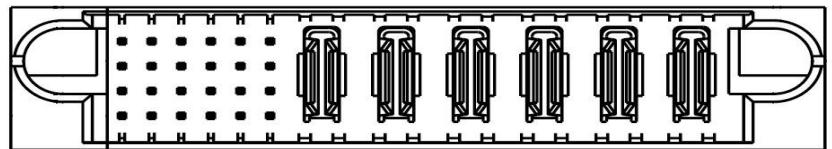

View from power supply output connector end

Output Connector – Control Signals

- A1 – PS_ON
- A2 – Main Output Remote Sense Return
- A3 – Spare
- A4 – PS_SEATED
- A5 – StandBy Output
- A6 – StandBy Output Return
- B1 – AC_OK
- B2 – Main Output Remote Sense
- B3 – Main Output Current Share
- B4 – PS_INHIBIT
- B5 – StandBy Output
- B6 – StandBy Output Return
- C1 – SDA (I²C Data Signal)
- C2 – SCL (I²C Clock Signal)
- C3 – POWER GOOD
- C4 – Spare
- C5 – StandBy Output
- C6 – StandBy Output Return
- D1 – A0 (I²C Address BIT 0 Signal)
- D2 – A1 (I²C Address BIT 1 Signal)
- D3 – S_INT (Alarm)
- D4 – StandBy Remote Sense
- D5 – StandBy Output
- D6 – StandBy Output Return

D1	D2	D3	D4	D5	D6	PB1	PB2	PB3	PB4	PB5	PB6
C1	C2	C3	C4	C5	C6						
B1	B2	B3	B4	B5	B6						
A1	A2	A3	A4	A5	A6						

Power / Signal Mating Connectors and Pin Types

Table 5. Mating Connectors for DS1200-3 series

Reference	On Power Supply	Mating Connector or Equivalent
AC Input Connector	IEC320-C19	IEC320-C20
Output Connector	FCI Power Blade 51721-10002406AA or	FCI Power Blade 51741-10002406CC Straight Pins
	Molex Power Connector 87667-7002	FCI Power Blade 51761-10002406AALF Right Angle Pins

LED indicator Definition

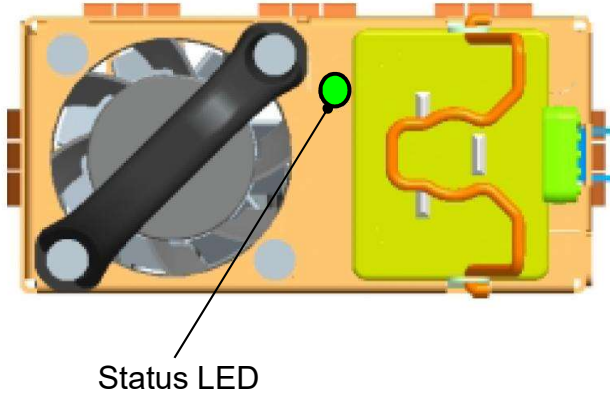

One bi-color (green/amber) LED at the power supply front provides status signal. The status LED conditions are shown on the below table.

Condition	LED Status
$V_{SB} = ON, V_O = OFF, AC\ Input = ON$	Blinking Green
$V_{SB} = ON, V_O = ON$	Solid Green
$V_O = OCP / UVP / OVP$	Blinking Amber
$FAN_FAULT / OTP / V_{SB} = OCP/UVP$	Solid Amber

Weight

The DS1200-3 series weight is 2.9 lbs. maximum.

Environmental Specifications

EMC Immunity

DS1200-3 series power supply is designed to meet the following EMC immunity specifications:

Table 6. Environmental Specifications:

Document	Description
FCC Part 15 Subpart J Class B/ EN55022, Level B	Conducted and Radiated EMI Limits
EN61000-3-2	Harmonics
EN61000-3-3	Voltage Fluctuations
IEC/EN 61000-4-2	Electromagnetic Compatibility (EMC) - Testing and measurement techniques – Electrostatic discharge immunity test. +/-15KV air, +/-8KV contact discharge, performance Criteria B
IEC/EN 61000-4-31	Electromagnetic Compatibility (EMC) - Testing and measurement techniques, Radiated, radio-frequency, electromagnetic field immunity test
IEC/EN 61000-4-4	Electromagnetic Compatibility (EMC) - Testing and measurement techniques, Electrical Fast Transient/Burst Immunity Test. 2KV for AC power port, 1.0KV for DC ports, I/O and signal ports performance Criteria B
IEC/EN 61000-4-5	Electromagnetic Compatibility (EMC) - Testing and measurement techniques – 2KV common mode and 1KV differential mode for AC ports and 0.5kV differential mode for DC power, I/O and signal ports, performance criteria B.
IEC/EN 61000-4-1	Electromagnetic Compatibility (EMC) - Testing and measurement techniques : Voltage Dips and Interruptions: 30% reduction for 500ms- Criteria B>95% reduction for 10mS, Criteria A, >95% reduction for 5000mS, Criteria C
EN55024	Information Technology Equipment-Immunity Characteristics, Limits and Method of Measurements

Safety Certifications

The DS1200-3 power supply is intended for inclusion in other equipment and the installer must ensure that it is in compliance with all the requirements of the end application. This product is only for inclusion by professional installers within other equipment and must not be operated as a stand alone product.

Table 7. Safety Certifications for DS1200-3 series power supply system

Document	File #	Description
UL62368-1	E186249 V1 S284	US and Canada Requirements
IEC62368-1	392496	International Requirements
EN62368-1	P20224428	European Requirements
CB Certificate and Report	NO102924	(All CENELEC Countries)
CHINA CCC Approval	2009010907324565	China Requirements

EMI Emissions

The DS1200 series has been designed to comply with the Class B limits of EMI requirements of EN55022 (FCC Part 15) and CISPR 22 (EN55022) for emissions and relevant sections of EN61000 (IEC 61000) for immunity. The unit is enclosed inside a metal box, tested at 1200W using resistive load with cooling fan.

Conducted Emissions

The applicable standard for conducted emissions is EN55022 (FCC Part 15). Conducted noise can appear as both differential mode and common mode noise currents. Differential mode noise is measured between the two input lines, with the major components occurring at the supply fundamental switching frequency and its harmonics. Common mode noise, a contributor to both radiated emissions and input conducted emissions, is measured between the input lines and system ground and can be broadband in nature.

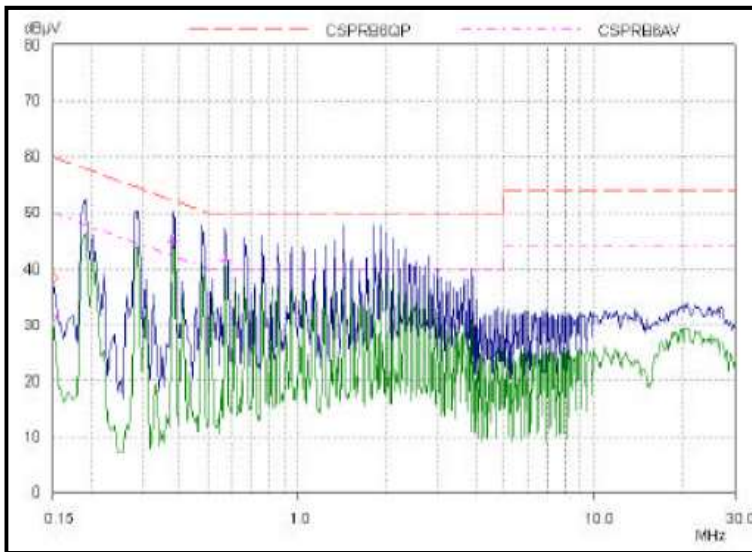

The DS1200-3 power supplies have internal EMI filters to ensure the converters' conducted EMI levels comply with EN55022 (FCC Part 15) Class B and EN55022 (CISPR 22) Class B limits. The EMI measurements are performed with resistive loads at maximum rated loading.

Sample of EN55022 Conducted EMI Measurement at 100Vac input

Note: Red Line refers to Artesyn Quasi Peak margin, which is 6dB below the CISPR international limit. Pink Line refers to the Artesyn Average margin, which is 6dB below the CISPR international limit.

Table 6. Conducted EMI emission specifications of the DS1200-3 series

Parameter	Model	Symbol	Min	Typ	Max	Unit
FCC Part 15, class B	All	Margin	6	-	-	dB
CISPR 22 (EN55022) class B	All	Margin	6	-	-	dB

Radiated Emissions

Unlike conducted EMI, radiated EMI performance in a system environment may differ drastically from that in a stand-alone power supply. The shielding effect provided by the system enclosure may bring the EMI level from Class A to Class B. It is thus recommended that radiated EMI be evaluated in a system environment. The applicable standard is EN55022 Class A (FCC Part 15). Testing ac-dc convertors as a stand-alone component to the exact requirements of EN55022 can be difficult, because the standard calls for 1m leads to be attached to the input and outputs and aligned such as to maximize the disturbance. In such a set-up, it is possible to form a perfect dipole antenna that very few ac-dc convertors could pass. However, the standard also states that 'an attempt should be made to maximize the disturbance consistent with the typical application by varying the configuration of the test sample.

Operating Temperature

The DS1200-3 series power supply will start and operate within stated specifications at an ambient temperature from -10 °C to 50 °C under all load conditions with internal fan. DS1200-3-002 and DS1200-3-401 can operate up to 70 °C with derated power.

Forced Air Cooling

The DS1200-3 series power supply included internal cooling fans as part of the power supply assembly to provide forced air-cooling to maintain and control temperature of devices and ambient temperature in the power supply to appropriate levels. The standard direction of airflow is from the DC connector end to the AC connector end of the power supply.

The cooling fan is a variable speed fan. The fan speed is controlled by the PWM duty cycle of the fan supply voltage depending on the main output 12V load condition per below table:

Fan PWM Duty Cycle	Main Output (12V) Load (A)	
	110 Vac	230 Vac
100%	81.6	98.4
77%	75.5	93.5
73%	69.4	88.5
62%	63.2	83.6
54%	57.1	78.7
41%	51.0	73.8
38%	44.88 and below	68.9 and below
38%	Stand-By Mode	Stand-By Mode

Power Derating Curves

DS1200-3-002 and DS1200-3-401 can operate up to a maximum ambient temperature of 70°C with derating. Power derating starts when ambient reaches 60°C. Beyond 60°C, nominal power reduced to 650W for high line and 550W for low line (shown in Red Curve in the Power Derating Curves below). When ambient temperature drops back down to 55°C, DS1200-3-002 and DS1200-3-401 will able to deliver full rated power again (shown by the Blue Curve in the Power Derating Curves). See tables below for nominal output current / power and OCP limits at high temperature operation.

Output	Input AC line	Nominal Output Current /Power (T _A > 60°C)
V _O Output	Low Line (90 to 179Vac) High Line (180 to 264Vac)	46A / 550W 55A / 650W
3.3V Standby	All	4A
5V Standby	All	2.5A

Output	Input AC line	OCP Limit (T _A > 60°C)
V _O Output	All	58A - 65A
3.3V Standby	All	4.4A - 9A
5V Standby	All	3A - 9A

High Line Power Derating Hysteresis

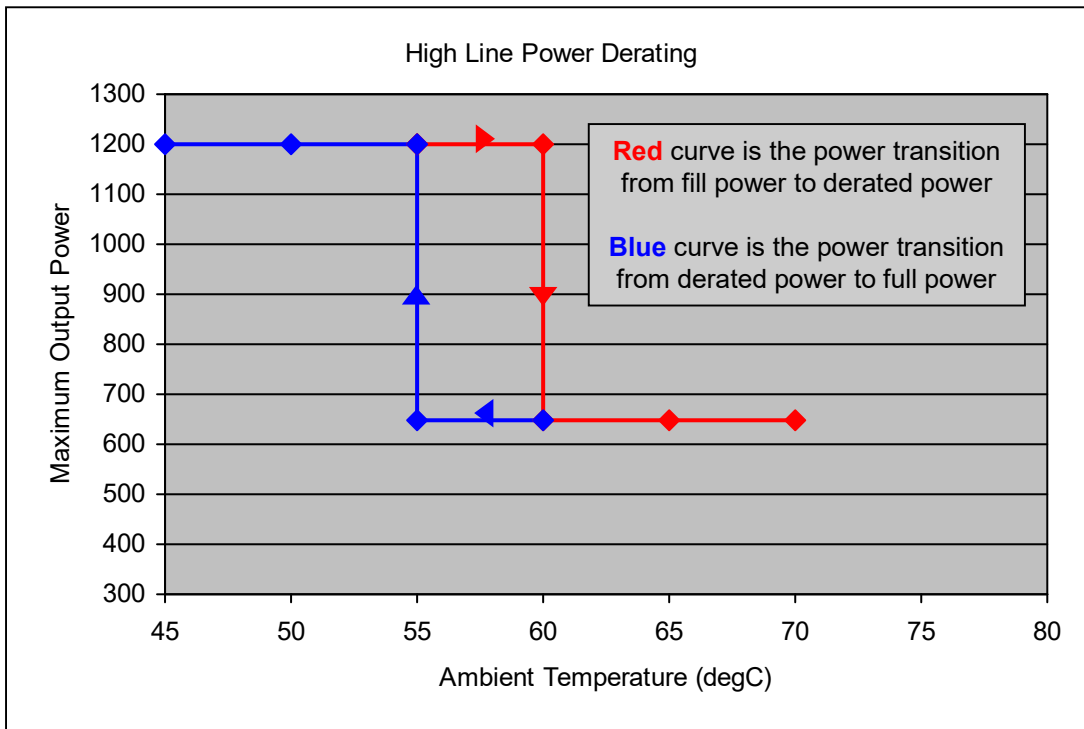

Low Line Power Derating Hysteresis

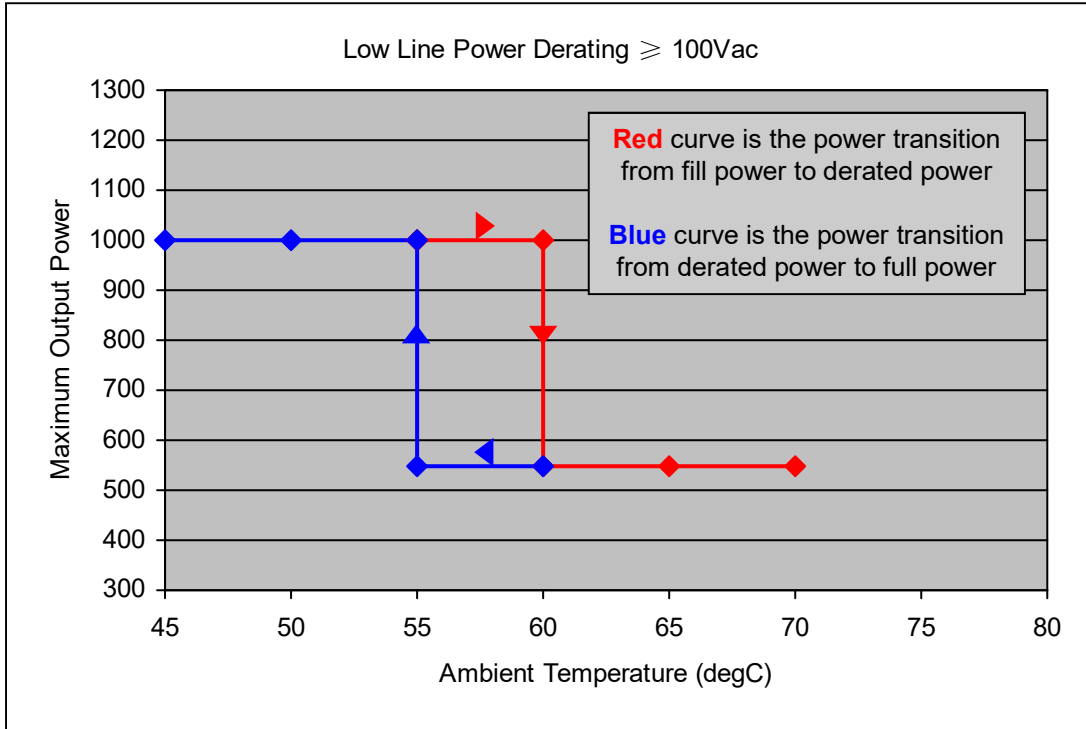

Note 1 - Rated output power 1000W at 100Vac line condition, for lower line voltage derate output power to 550W (thermal limitation due to OTP Protection) for 56 to 60°C ambient temperature

Storage and Shipping Temperature / Humidity

The DS1200-3 series power supply can be stored or shipped at temperatures between -40°C to $+85^{\circ}\text{C}$ and relative humidity from 5% to 95% non-condensing.

Altitude

The DS1200-3 series power supply will operate within specifications at altitudes up to 10,000 feet above sea level. The power supply shall not be damaged when stored at altitudes of up to 30,000 feet above sea level.

Humidity

The DS1200-3 series power supply will operate within specifications when subjected to a relative humidity from 20% to 90% non-condensing. The DS1200-3 series can be stored in a relative humidity from 10% to 95% non-condensing.

Vibration

The DS1200-3 series power supply will pass the following vibration specifications:

Non-Operating Random Vibration

Acceleration	2.7	gRMS
Frequency Range	10-2000	Hz
Duration	20	mins
Direction	3 mutually perpendicular axis	
PSD Profile	FREQ	SLOPE
		dB/oct
		PSD
		g^2/Hz
	10-190 Hz	---
	190-210 Hz	-31.213dB/oct
	210-2000 Hz	---
		0.01 g^2/Hz

		0.003 g^2/Hz

Operating Random Vibration

Acceleration	1.0	gRMS
Frequency Range	10-500	Hz
Duration	20	mins
Direction	3 mutually perpendicular axis	
PSD Profile	FREQ	SLOPE
		dB/oct
		PSD
		g^2/Hz
	10-500 Hz	---
		0.002 g^2/Hz

Shock

The DS1200-3 series power supply will pass the following vibration specifications:

Non-Operating Half-Sine Shock

Acceleration	30	G
Duration	18	msec
Pulse	Half-Sine	
No. of Shock	3 shock on each of 6 faces	

Operating Half-Sine Shock

Acceleration	4	G
Duration	22	msec
Pulse	Half-Sine	
No. of Shock	3 shock on each of 6 faces	

Power and Control Signal Descriptions

AC Input Connector

This connector supplies the AC Mains to the DS1200-3 series power supply.

- Pin 1 - L1
- Pin 2 - L2
- Pin 3 - Earth Ground

Output Connector – Power Blades

These pins provide the main output for the DS1200-3 series power supply. The + Main Output (V_O) and the Main Output Return pins are the positive and negative rails, respectively, of the V_O main output of the DS1200-3 power supply. The Main Output (V_O) is electrically isolated from the power supply chassis.

- PB1 - Main Output Return
- PB2 - Main Output Return
- PB3 - Main Output Return
- PB4 - + Main Output (V_O)
- PB5 - + Main Output (V_O)
- PB6 - + Main Output (V_O)

Output Connector - Control Signals

The DS1200-3 series power supply contains a 24 pins control signal header providing an analogue control interface, standby power and i²C interface signal connections.

PS_ON – (pin A1)

This signal input pin controls the normal turning ON and Off of the Main Output of the DS1200-3 power supply. The power supply main output (V_O) will be enabled when this signal is pulled low, below 0.8 V. The Power supply output (except V_{SB} output) will be disabled when this input is driven higher than 2.4V, or left open circuited.

Main Output Remote Sense Return, Main Output Remote Sense – (pins A2, B2)

The main output of the DS1200-3 is equipped with a Remote Sensing capability that will compensate for a power path drop around the entire loop of 1 volt. This feature is implemented by connecting the Main Output Remote Sense (pin B2) and the Main Output Remote Sense Return (pin A2) to the positive and negative rails of the main output, respectively, at a location that is near to the load. Care should be taken in the routing of the sense lines as any noise sources or additional filtering components introduced into the voltage rail may affect the stability of the power supply. The DS1200-3 will operate appropriately without the sense lines connected; however it is recommended that the sense lines be connected directly to the main output terminals if remote sensing is not required. This remote sense circuit will not raise the power supply's output voltage to the OVP trip level.

Main Output Remote Sense has no effect on the Standby Output (V_{SB}).

PS_SEATED – (pin A4)

This signal pin is connected to Main Output Return inside the power supply via a 220 ohm resistor. This pin is to be pull high on the system side by a resistor of 4.7K or higher. A TTL logic LOW indicates the power supply is inserted and seated into the system power supply connector. A Logic HIGH indicated the removal of the power supply.

StandBy Output, StandBy Output Return – (pins A5, A6, B5, B6, C5, C6, D5, D6)

The DS1200-3 series power supply provides a regulated 3.3 volt 6 amp (or 5.0 volt 4 amp) auxiliary output voltage to power critical circuitry that must remain active regardless of the on/off status of the power supply's main output. The Standby Output (V_{SB}) voltage is available whenever a valid AC input voltage is applied to the unit. The StandBy Output is independently short circuit protected and is referenced to the StandBy Output Return pins (A6, B6, C6, D6).

AC_OK – (pin B1)

The AC_OK signal is a normally LOW level TTL logic signal when the AC input voltage is within the allowable limits. A TTL logic HIGH level, with a 5mS early warning will be sent before the main output loses regulation. This signal is an open drain output internally pulled up in the power supply to StandBy Output via a 1K ohm resistor. It is capable of driving the output below 0.4V with a load of 4mA.

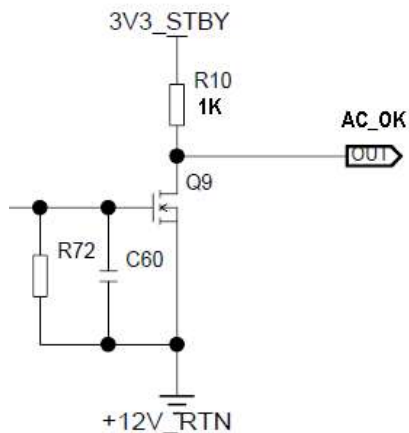

Main Output Current Share – (pin B3)

The DS1200-3 supports active current sharing through a single wire connection between the power supplies. This input/output signal pin allows two or more power supplies to share the main output load current to increase the overall power capability or to operate the units in a N+1 configuration for redundancy purposes.

The voltage of this signal will be a linear slope from no load to full load. At 49.2A, the output of the Main Output Current Share pin will be between 3.75 and 4.25V. At 98.4A output current, this signal will be between 7.75 and 8.25V.

When two or more power supplies are connected and operating in parallel and each is delivering 40-100% of its rated output to the load, the power supplies will current share within 5% accuracy. When supplying light loads between 10% and 40% of its rated load, the power supplies will share within 20% accuracy. (Below 10% load, there is no guarantee of output current sharing). If any power supply is hot swapped, no glitch will occur that violates the regulation limits of the power supply defined in this specification.

PS_INHIBIT – (pin B4)

This signal pin should be grounded in the system. If left open, power supply operation will be inhibited (StandBy V_{SB} output will remain on).

SDA, SCL and S_INT – (pin C1, C2, D3)

Please refer to “Communication Bus Descriptions” section.

POWER GOOD– (pin C3)

The POWER GOOD is an output signal driven high, by the power supply to indicate that all outputs are valid. If any of the power supply outputs fails below its regulation limits, this output will be driven low. The output signal is an open drain output internally pulled up in the power supply to internal standby supply (anode side of StandBy Output or'ing circuit) via a 1K ohm resistor. It is capable of driving the output below 0.4V with a load of 4mA.

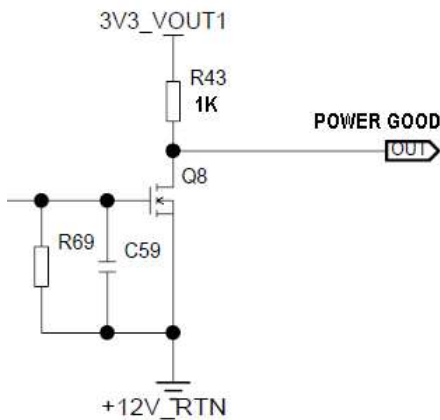

A0, A1 – (pins D1, D2)

Please refer to “Communication Bus Descriptions” section.

StandBy Remote Sense – (pin D4)

The StandBy Output of the DS1200-3 is also equipped with a Remote Sensing capability that will compensate upto 50mV of voltage drop for the positive rail. The StandBy Output Remote Sense pin should be connected as close to the load as possible, or connected to the StandBy Output pins at the base of the output connector if not used. If left open, the remote sense might not work properly and the voltage level of StandBy Output can be lower than the guaranteed spec.

Communication Bus Descriptions

I²C Bus Signals

The DS1200-3 series power supply contains enhanced monitoring and control functions implemented via the I²C bus. The DS1200-3 series power supply I²C functionality (PMBus™ and FRU data) can be accessed via the output connector control signals. The communication bus is powered either by the internal 3.3V supply or from an external power source connected to the StandBy Output (ie: accessing an unpowered power supply as long as the StandBy Output of another power supply connected in parallel is on).

If units are connected in parallel or in redundant mode, the StandBy Outputs must be connected together in the system. Otherwise, the I²C bus will not work properly when a unit is inserted into the system without the AC source connected.

Note: PMBus™ functionality can be accessed only when the PSU is powered-up.
Guaranteed communication I²C speed is 100KHz.

SDA, SCL (I²C Data and Clock Signals) – (pin C1, C2)

I²C serial data and clock bus - these pins are internally pulled up to internal 3.3V supply with a 39K resistor. These pins must be pulled-up in the system by an 1K ohm resistor to the StandBy Output.

S_INT (Alarm) – (pin D3)

S_INT is used to send a signal to the system that a fault in the power supply occurred. This signal is normally logic level HIGH. It will go to a LOW logic level when a fault bit has been set in the power supply's status register. To reset the S_INT signal back to normal (logic HIGH level), perform one of the following actions - (1) recycle input AC power, (2) toggle PSON signal and (3) issuance of a CLEAR_FAULTS PMBus™ command.

A0, A1 (I²C Address BIT 0, BIT1 Signals) – (pin D1, D2)

These two input pins are the address lines A0 and A1 to indicate the slot position the power supply occupies in the power bay and define the power supply addresses for FRU data and PMBus™ data communication. This allows the system to assign different addresses for each power supply. During I²C communication between system and power supplies, the system will be the master and power supplies will be slave.

They are internally pulled up to internal 3.3V supply with a 1K resistor.

I²C Bus Communication Interval

The interval between two consecutive I²C communications to the power supply should be at least 50ms to ensure proper monitoring functionality.

I²C Bus Signal Integrity

The noise on the I²C bus (SDA, SCL lines) due to the power supply will be less than 500mV peak-to-peak. This noise measurement should be made with an oscilloscope bandwidth limited to 100MHz. Measurements should be made at the power supply output connector with 3.2K ohm resistors pulled up to StandBy Output and 20pf ceramic capacitors to StandBy Output Return.

The noise on the address lines A0 and A1 will be less than 100mV peak-to-peak. This noise measurement should be made at the power supply output connector.

I²C Bus Internal Implementation, Pull-ups and Bus Capacitances

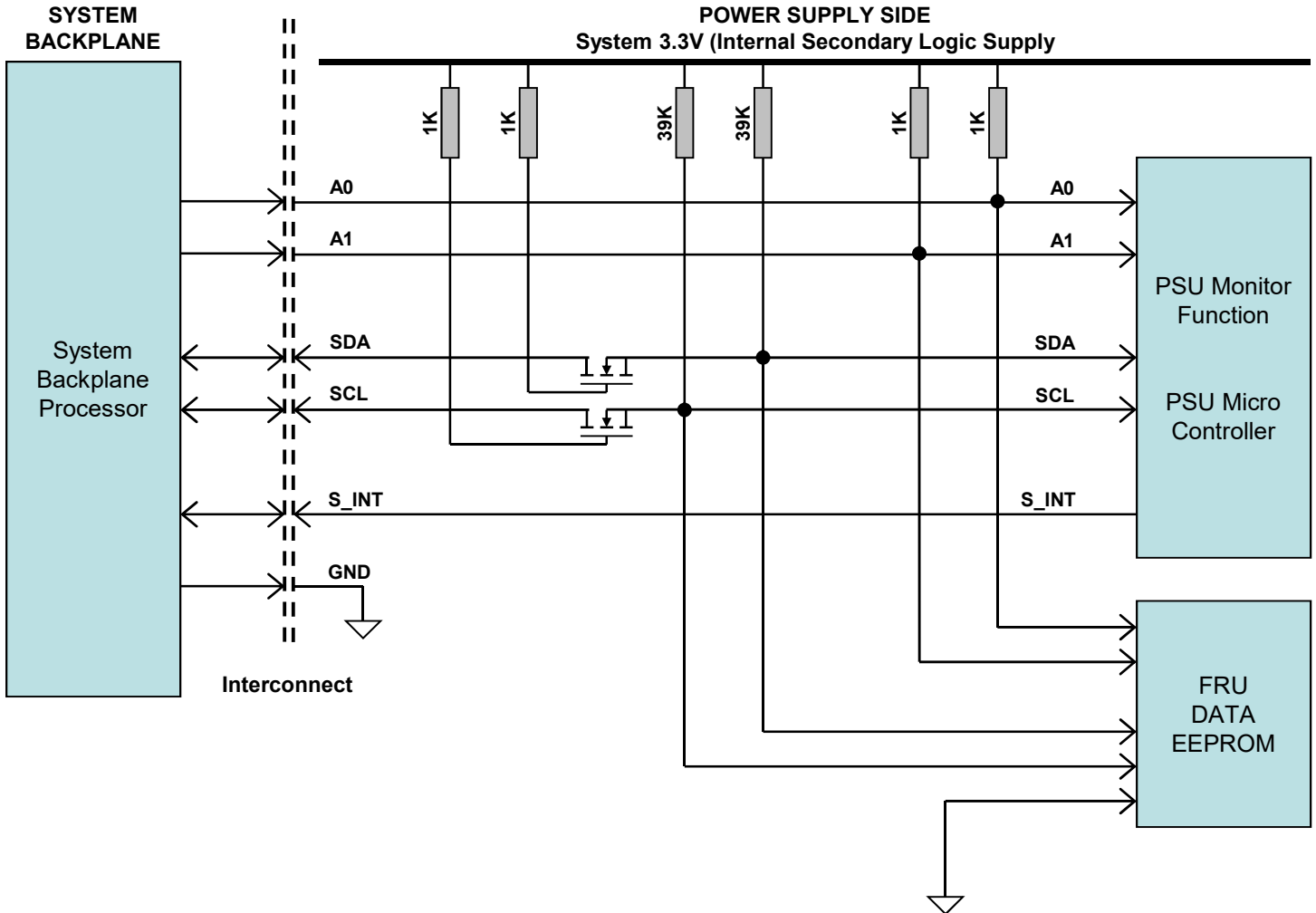

I²C Bus - Recommended external pull-ups:

Electrical and Interface specifications of I²C signals (referenced to StandBy Output Return pin, unless otherwise indicated):

Parameter	Condition	Symbol	Min	Typ	Max	Unit
SDA, SCL internal pull-up resistor		R_{int}	-	39	-	Kohm
SDA, SCL internal bus capacitance		C_{int}	-	0	-	pF
Recommended external pull-up resistor	1 to 4 PSU	R_{ext}	-	1.0	-	Kohm

Logic Levels

DS1200-3 series power supply I²C Communication Bus will respond to logic levels as per below:

Logic High: 3.3V Nominal (Specs is 2.1V to 5.5V)**

Logic Low: 500mV nominal (Specs is 800mV max)**

**Note: Artesyn 73-769-001 I²C adapter was used.

Timings

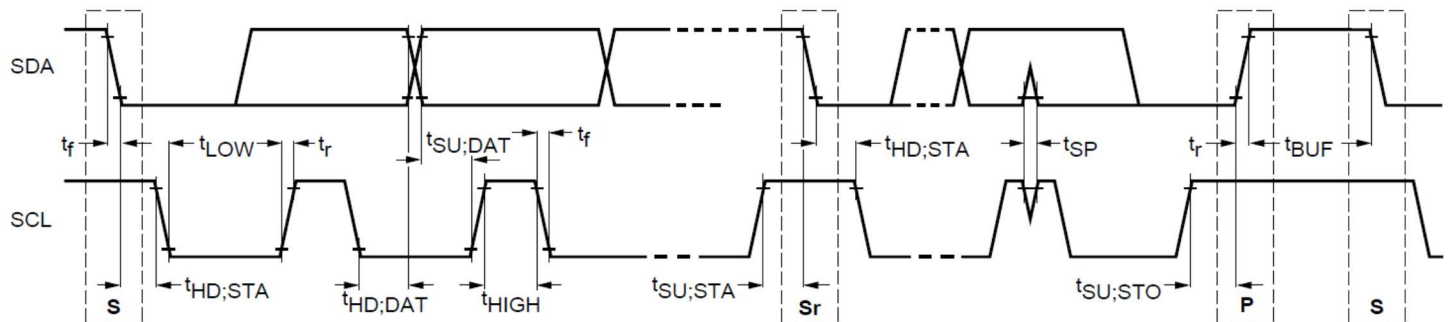

Parameter	Symbol	Standard-Mode Specs		Actual Measured		Unit
		Min	Max			
SCL Clock Frequency	f_{SCL}	0	100	96.8		KHz
Hold time (repeated) START condition	$t_{HD;STA}$	4.0	-	4.3		μS
LOW period of SCL clock	t_{LOW}	4.7	-	13.5		μS
HIGH period of SCL clock	t_{HIGH}	4.0	-	4.4		μS
Setup time for repeated START condition	$t_{SU;STA}$	4.7	-	5.83		μS
Data hold time	$t_{HD;DAT}$	0	3.45	1.87		μS
Data setup time	$t_{SU;DAT}$	250	-	5765		nS
Rise time	t_r	-	1000	SCL = 972	SDA = 986	nS
Fall time	t_f	-	300	SCL = 148.5	SDA = 148	nS
Setup time for STOP condition	$t_{SU;STO}$	4.0	-	6.36		μS
Bus free time between a STOP and START condition	t_{BUF}	4.7	-	100***		μS

*** Note Artesyn 73-769-001 I²C adapter (USB-to-I²C) and Universal PMBus™ GUI software was used

Device Addressing

The DS1200-3 series power supply will respond to supported commands on the I²C bus that are addressed according to pins A1 and A0 pins of output connector.

Address pins are held HIGH by default via pulled up to internal 3.3V (5V) supply with a 1K resistor. To set the address as "0", the corresponding address line should be pulled down to logic ground level. Below tables show the address of the power supply with A0 and A1 pins set to either "0" or "1".:

PSU Slot	Slot ID Bits		PMBus™ Address	EEPROM (FRU) Read Address
	A1	A0		
1	0	0	0x78	0xA9
2	0	1	0x7A	0xAB
3	1	0	0x7C	0xAD
4	1	1	0x7E*	0xAF*

* Default PMBus™ address when A0 and A1 are left open

Power Supply Status Register, PMBus™ Register 0xEFh

Power supply status monitoring can be done via the PMBus™ register 0xEFh or as I/O expander. Detailed explanation of functions is given below:

BIT 7	BIT 6	BIT 5	BIT 4	BIT 3	BIT 2	BIT 1	BIT 0
OCP	UVP	OVP	FAN_OK	AC_OK	TEMP_OK	V _{SB} OK	V _O OK

- OCP -Over Current Protection
-This bit will be set when the power supply outputs have been disabled due to an over current event.
- UVP -Under Voltage Protection
-This bit will be set when the power supply outputs have been disabled due to an under voltage event.
- OVP -Over Voltage Protection
-This bit will be set when the power supply outputs have been disabled due to an over voltage event.
- FAN_OK -Fan Status
-Any abnormalities on the fan will clear this bit. Normal fan operation, this is set to high.
- AC_OK -AC line voltage status
-This bit is an image of the AC_OK signal coming out the power supply to the system. A logic HIGH, if the input voltage is within allowable limits. This bit will be cleared when the power supply line voltage is past the trip limit.
- TEMP_OK -Over temperature status.
-A logic HIGH, when the power supply is operating within allowable temperature range. This bit will be cleared when the power supply temperature is past the trip limit.
- V_{SB} OK -StandBy Output (V_{SB}) status.
-This bit is set when the StandBy Output (V_{SB}) is within regulation limits. This bit will be cleared when the V_{SB} voltage is out of regulation.
- V_O OK -Main Output (V_O) status.
-This bit is set when the Main Output (V_O) is within regulation limits. This bit will be cleared when the V_O voltage is out of regulation.

Status Register Code		
Signal Name	Code (Binary)	Code (Hex)
Normal / 12V ON	00011111	1F
Normal / 12V OFF	00011110	1E
OCP	10011111	9E
UVP	01011110	5E
OVP	00111110	3E
Fan Fault	00001110	0E
Low AC / No AC	00010100	14
Over Temp Fault	00011010	1A

I²C Clock Synchronization

The DS1200-3 series power supply might apply clock stretching. An addressed slave power supply may hold the clock line (SCL) low after receiving (or sending) a byte, indicating that it is not yet ready to process more data. The system master that is communicating with the power supply will attempt to raise the clock to transfer the next bit, but must verify that the clock line was actually raised. If the power supply is clock stretching, the clock line will still be low (because the connections are open-drain).

The maximum time out condition for clock stretching for DS1200-3 is 100 microseconds.

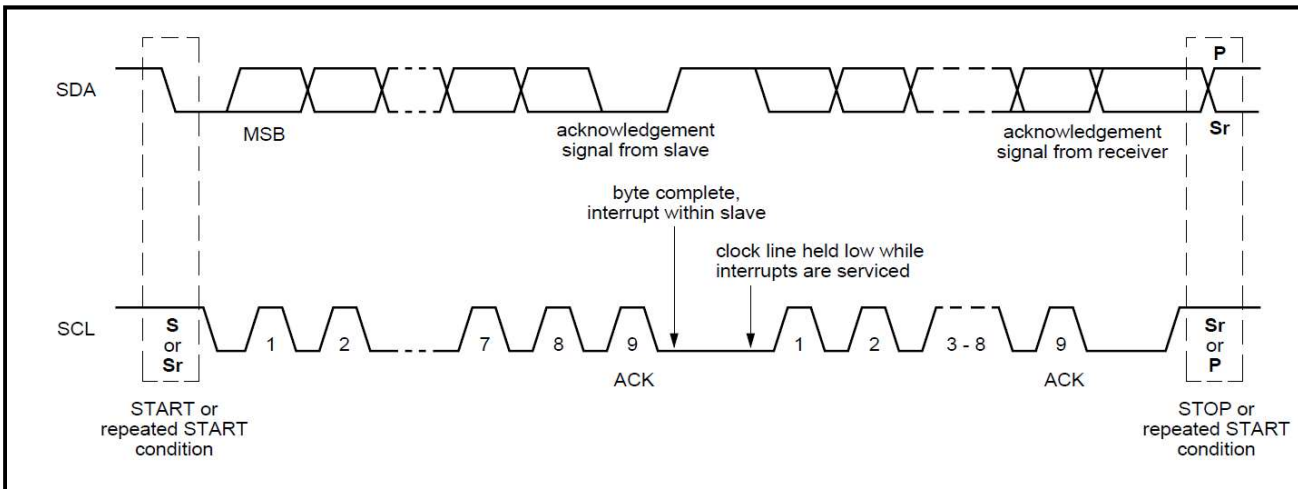

FRU (EEPROM) Data

The FRU (Field Replaceable Unit) data format is compliant with the Intel IPMI v1.0 specification.

The DS1200-3 uses 1 page of EEPROM for FRU purpose. A page of EEPROM contains up to 256 byte-sized data locations.

- Where:
- OFFSET** - The OFFSET denotes the address in decimal format of a particular data byte within DS1200-3 EEPROM.
 - VALUE** - The VALUE details data written to a particular memory location of the EEPROM.
 - DEFINITION** - The contents DEFINITION refers to the definition of a particular data byte.

DS1200-3 FRU (EEPROM) Data:

OFFSET		DEFINITION (REMARKS)	SPEC VALUE	
(DEC)	(HEX)		(DEC)	(HEX)
COMMON HEADER, 8 BYTES				
0	00	FORMAT VERSION NUMBER (Common Header) 7:4 - Reserved, write as 0000b 3:0 - Format Version Number = 1h for this specification	1	01
1	01	INTERNAL USE AREA OFFSET	27	1B
2	02	CHASSIS INFO AREA OFFSET	1	01
3	03	BOARD INFO AREA OFFSET	0	00
4	04	PRODUCT INFO AREA OFFSET	5	05
5	05	MULTI RECORD AREA OFFSET	12	0C
6	06	PAD (reserved) Default value is 0.	0	00
7	07	ZERO CHECK SUM (256 – (Sum of bytes 0 to 6))	210	D2
CHASSIS INFO AREA(32 BYTES) This area will be filled by the Mfg. Diag. or by the OS if used				
8	08	FORMAT VERSION NUMBER 7:4 - Reserved, write as 0000b 3:0 - Format Version Number = 1h for this specification	1	01
9	09	CHASSIS INFO AREA LENGTH in multiple of 8 bytes	4	04
10	0A	CHASSIS TYPE (Default value is 0.)	0	00
11	0B	CHASSIS PART NUMBER Type/Length CAh (if used) Type = "ASCII+LATIN1" = (11)b Length = 10 Bytes = (001010)b	202	CA
12	0C	CHASSIS PART NUMBER BYTES (Default value is 0.)	0	00
13	0D		0	00
14	0E		0	00
15	0F		0	00
16	10		0	00
17	11		0	00
18	12		0	00
19	13		0	00
20	14		0	00
21	15		0	00
22	16	CHASSIS SERIAL NUMBER Type/Length CFH (if used) Type = "ASCII+LATIN1" = (11)b Length = 15 Bytes = (001111)b	207	CF
23	17	CHASSIS SERIAL NUMBER BYTES , Default value is 0.	0	00
24	18		0	00
25	19		0	00
26	1A		0	00
27	1B		0	00
28	1C		0	00
29	1D		0	00
30	1E		0	00
31	1F		0	00
32	20		0	00

Technical Reference Note

DS1200-3 FRU (EEPROM) Data:

OFFSET		DEFINITION (REMARKS)	SPEC VALUE	
(DEC)	(HEX)		(DEC)	(HEX)
33	20	CHASSIS SERIAL NUMBER BYTES, Default value is 0.	0	00
34	22		0	00
35	23		0	00
36	24		0	00
37	25		0	00
38	26	End Tag (0C1h if used)	193	C1
39	27	CHKSUM (Zero CHKSUM if used)	161	A1
PRODUCT INFORMATION AREA, 56 BYTES				
40	28	FORMAT VERSION NUMBER (Product Info Area) 7:4 - Reserved, write as 0000b 3:0 - Format Version Number = 1h for this specification	1	01
41	29	PRODUCT INFO AREA LENGTH (In multiples of 8 bytes)	7	07
42	2A	Language (English)	25	19
43	2B	MANUFACTURER NAME TYPE / LENGTH (0C5H) Type "ASCII+LATIN1" 5 Bytes.	197	C5
44	2C	MANUFACTURER'S NAME 5 byte sequence "E"= 41h "M"= 53h "R"= 54h "S"= 45h "N"= 43h	65	41
45	2D		83	53
46	2E		84	54
47	2F		69	45
48	30		67	43
49	31	PRODUCT NAME Type/Length (CCH) Type = "ASCII+LATIN1" = (11)b Length = 12 Bytes = (001100)b	204	CC
50	32	Product Name , 12 Byte sequence "DS1200-3 " In Decimal = 068, 083, 049, 050, 048, 048, 045, 051, 032, 032, 032, 032, In Hex = 44H, 53H, 31H, 32H, 30H, 30H, 2DH, 33H, 20H, 20H, 20H, 20H	68	44
51	33		83	53
52	34		49	31
53	35		50	32
54	36		48	30
55	37		48	30
56	38		45	2D
57	39		51	33
58	3A		32	20
59	3B		32	20
60	3C		32	20
61	3D	32	20	
62	3E	PRODUCT PART/MODEL NUMBER Type/Length (CCH) Type = "ASCII+LATIN1" = (11)b Length = 12 Bytes = (001100)b	204	CC
63	3F	Part / Model Number "DS1200-3 " In Decimal = 068, 083, 049, 050, 048, 048, 045, 051, 032, 032, 032, 032, In Hex = 44H, 53H, 31H, 32H, 30H, 30H, 2DH, 33H, 20H, 20H, 20H, 20H,	68	44
64	40		83	53
65	41		49	31
66	42		50	32
67	43		48	30
68	44		48	30
69	45		45	2D
70	46		51	33
71	47		32	20
72	48		32	20
73	49		32	20
74	4A		32	20
75	4B	PRODUCT VERSION NUMBER Type/Length (C2h) Type = "ASCII+LATIN1" = (11)b Length = 2 bytes = (000010)b	194	C2
76	4C	Refer to Section 1.2 Product Revision History (Model Revision) in latest IPS Eg. "0A" In Decimal = 048, 065 In Hex = 30H, 41H	XX	XX
77	4D		XX	XX

Technical Reference Note

DS1200-3 FRU (EEPROM) Data:

OFFSET		DEFINITION	SPEC VALUE	
(DEC)	(HEX)	(REMARKS)	(DEC)	(HEX)
78	4E	PRODUCT SERIAL NUMBER Type/Length Type = "ASCII+LATIN1" = (11)b Length = 13 bytes = (001101)b	205	CD
79	4F	Model ID	71	47
80	50	"G087" for DS1200-3	48	30
81	51	In Decimal = 071, 048, 056, 055	56	38
82	52	In Hex = 47H, 30H, 38H, 37H	55	37
MANUFACTURING YEAR AND WEEK CODE				
83	53	"WW"	87	57
84	54	In Decimal = 087, 087 In Hex = 57H, 57H	87	57
Unique Serial Number				
85	55	"SSSS"	83	53
86	56		83	53
87	57	In Decimal = 083, 083, 083, 083	83	53
88	58	In Hex = 53H, 53H, 53H, 53H	83	53
MODEL REVISION				
89	59	Astec Model Rev, See Latest Model Rev in IPS Sec 1.2	XX	XX
90	5A	Eg. "0A" In Decimal = 048, 065 In Hex = 30H, 41H	XX	XX
MANUFACTURING LOCATION				
91	5B	"P" In Decimal = 080 In Hex = 50H	80	50
92	5C	End Tag In Decimal: 193 In Hex: 0C1H	193	C1
93	5D	PAD (reserved), Default value is 0.	0	00
94	5E		0	00
95	5F	ZERO CHECK SUM (256 – (Sum of bytes 40 to 94)) Zero Check Sum :Should follow check sum calculation as per IPMI v1.1 specs	193	C1
Multi Record Area, 88 Bytes				
Power Supply Record Header				
96	60	Record type = 00 for Power supply	0	00
97	61	End of List /Record Format Version Number	2	02
98	62	Record Length of Power Supply Record	24	18
99	63	Record CHECKSUM of Power Supply Record (Zero CHECKSUM) 256-(sum of bytes 101 to 124)	118	76
100	64	Header CHECKSUM of Power Supply Record Header (Zero CHECKSUM) (256-(sum of bytes 96 to 99))	112	70
Power Supply Record				
Overall Capacity of the Power Supply, 1200W = 04B0H				
101	65	2 Bytes Sequence In Decimal = 176, 004	176	B0
102	66	In Hex = B0H, 04H	4	04
Peak VA, 1348W = 0544H				
103	67	2 Bytes Sequence In Decimal = 068, 005	68	44
104	68	In Hex = 44H, 05H	5	05
Inrush Current, 40A				
105	69	In Decimal = 040 In Hex = 28H	40	28
Inrush Interval, 10mS				
106	6A	In Decimal = 010 In Hex = 0AH	10	0A
Low End Input Voltage Range 1(10mV), (90V / 10mV) 9000 = 2328H				
107	6B	2 Bytes Sequence In Decimal = 040, 035	40	28
108	6C	In Hex = 28H, 23H	35	23
High End Input Voltage Range 1(10mV), (264V/10mV) 26400= 6720H				
109	6D	2 Bytes Sequence In Decimal = 032, 103	32	20
110	6E	In Hex = 20H, 67H	103	67

Technical Reference Note

DS1200-3 FRU (EEPROM) Data:

OFFSET		DEFINITION (REMARKS)	SPEC VALUE	
(DEC)	(HEX)		(DEC)	(HEX)
111	6F	Low End Input Voltage Range 2(10mV) Not Applicable (Autoswitch)	0	00
112	70		0	00
113	71	High End Input Voltage Range 2(10mV) Not Applicable (Autoswitch)	0	00
114	72		0	00
115	73	Low End Input Frequency Range, 47Hz = 2FH	47	2F
116	74	Low End Input Frequency Range, 63Hz = 3FH	63	3F
117	75	AC Dropout Tolerance in ms, 10mS= 0AH	10	0A
118	76	Binary Flags , 1 indicates function supported and a 0 indicates function not supported. Bits 7-5: RESERVED, WRITE AS 000B Bit 4: Tachometer Pulses Per Rotation / Predictive Fail Polarity BIT = 0 Bit 3: Hot Swap / Redundancy Support BIT = 1 Bit 2: Auto switch Support BIT = 1 Bit 1: Power Factor Correction Support BIT = 1 Bit 0: Predictive Fail Support BIT = 0	14	0E
119	77	Peak Wattage Capacity and Holdup Time , 1800W = 708H 1 Second=01H Bits 15-12: Holdup Time in Seconds 1 = 01H Bits 11- 0: Peak Capacity in Watts 1800 = 708H 2 Bytes sequence: In Decimal: 008, 023 In Hex: 08H, 17H	8	08
120	78		23	17
121	79	Combined Wattage , Not Applicable Byte 1 00110000B =30H=48d Bits 7-4: 0011B --->(3.3v) Bits 3-0: 0000B --->(12v) Byte 2 and Byte 3: 1200W =04B0H byte 2 (LSB) = B0h =176d , byte 3 (MSB) =04h = 04d 3 Bytes Sequence In Decimal = 048d, 176d, 04d In Hex = 30H, B0H, 04H	48	30
122	7A		176	B0
123	7B		4	04
124	7C	Predictive Fail Tachometer Lower Threshold , Not Applicable. Predictive Failure is not Supported.	0	00
12V DC OUTPUT RECORD HEADER				
125	7D	Record type = 01 for DC Output Record	1	01
126	7E	End of List /Record Format Version Number for 12V DC Output Record	2	02
127	7F	Record Length of 12V DC Output Record	13	0D
128	80	Record CHECKSUM of 12V DC Output Record (Zero CHECKSUM) (256-(sum of bytes 130 to 142)	52	34
129	81	Header CHECKSUM of 12V DC Output Record Header (Zero CHECKSUM) (256-(sum of bytes 125 to 128)	188	BC
12V OUTPUT RECORD				
130	82	Output Information , 001 = 01H Bit 7: Standby Information = 0B Bits 6-4: Reserved, Write as 000B Bits 3-0: Output Number 1 = 001B	1	01
131	83	Nominal Voltage (10mV), (12V / 10mV) 1200 = 04B0H 2 Bytes Sequence In Decimal: 176, 004 In Hex: B0H, 04H	176	B0
132	84		4	04
133	85	Maximum Negative Voltage Deviation (10mV) , 1140 = 0474H 2 Bytes Sequence In Decimal: 116, 004 In Hex: 74H, 04H	116	74
134	86		4	04

Technical Reference Note

DS1200-3 FRU (EEPROM) Data:

OFFSET		DEFINITION (REMARKS)	SPEC VALUE	
(DEC)	(HEX)		(DEC)	(HEX)
135 136	87 88	Maximum Positive Voltage Deviation (10mV), 1260 =04ECH 2 Bytes Sequence In Decimal: 236, 004 In Hex: ECH, 04H	236 4	EC 04
137 138	89 8A	Ripple and Noise pk-pk (mV), 120 = 78H 2 Bytes Sequence In Decimal: 120, 000 In Hex: 78H, 00H	120 0	78 00
139 140	8B 8C	Minimum Current Draw (10mA), 0000 = 0000H 2 Bytes Sequence In Decimal: 000, 000 In Hex: 00H, 00H	0 0	00 00
141 142	8D 8E	Maximum Current Draw (10mA), 10000 = 2710H 2 Bytes Sequence In Decimal: 016, 039 In Hex: 10H, 27H	16 39	10 27
3V3SB OUTPUT RECORD HEADER				
143	8F	Record type = 01 for DC Output Record	1	01
144	90	End of List /Record Format Version Number for 3V3SB Output Record	2	02
145	91	Record Length of 3V3SB Output Record	13	0D
146	92	Record CHECKSUM of 3V3SB Output Record (Zero CHECKSUM) (256-(sum of bytes 148 to 160))	223	DF
147	93	Header CHECKSUM of 3V3SB Output Record Header (Zero CHECKSUM) (256-(sum of bytes 143 to 146))	17	11
3V3SB OUTPUT RECORD				
148	94	Output Information, 002 = 02H Bit 7: Standby Information = 1B Bits 6-4: Reserved, Write as 000B Bits 3-0: Output Number 2 = 010B	130	82
149 150	95 96	Nominal Voltage (10mV), (3.3V / 10mV) 330 = 014AH 2 Bytes Sequence In Decimal: 074, 001 In Hex: 4AH, 01H	74 1	4A 01
151 152	97 98	Maximum Negative Voltage Deviation (10mV), (3.14V/10mV) 314= 013AH 2 Bytes Sequence In Decimal: 058, 001 In Hex: 3AH, 01H	58 1	3A 01
153 154	99 9A	Maximum Positive Voltage Deviation (10mV), (3.46V/ 10mV) 346 =015AH 2 Bytes Sequence In Decimal: 090, 001 In Hex: 5AH, 01H	90 1	5A 01
155 156	9B 9C	Ripple and Noise pk-pk (mV), 50 = 0032H 2 Bytes Sequence In Decimal: 050, 000 In Hex: 32H, 00H	50 0	32 00
157 158	9D 9E	Minimum Current Draw (10mA), (0.5A / 10mA) 50 = 0032H 2 Bytes Sequence In Decimal: 050, 000 In Hex: 32H, 00H	50 0	32 00
159 160	9F A0	Maximum Current Draw (10mA), (6.0A / 10mA) 600 = 0258H 2 Bytes Sequence In Decimal: 88, 002 In Hex: 58H, 02H	88 2	58 02
OEM RECORD HEADER				
161	A1	Record type = C0H for OEM Record	192	C0
162	A2	End of List /Record Format Version Number for 3.3Vsb output Record	130	82

Technical Reference Note

DS1200-3 FRU (EEPROM) Data:

OFFSET		DEFINITION	SPEC VALUE	
(DEC)	(HEX)	(REMARKS)	(DEC)	(HEX)
163	A3	Record Length of OEM Record	50	32
164	A4	Record CHECKSUM of OEM Record (Zero CHECKSUM)	0	00
165	A5	Header CHECKSUM of OEM Record Header (Zero CHECKSUM) (256-(sum of bytes 161 to 164))	140	8C
OEM RECORD				
166	A6	Manufacturer ID (3 bytes, Default is 0)	0	00
167	A7		0	00
168	A8		0	00
169	A9	RESERVED	0	00
170	AA	RESERVED	0	00
171	AB	RESERVED	0	00
172	AC	RESERVED	0	00
173	AD	RESERVED	0	00
174	AE	RESERVED	0	00
175	AF	RESERVED	0	00
176	B0	RESERVED	0	00
177	B1	RESERVED	0	00
178	B2	RESERVED	0	00
179	B3	PAD (reserved), Default value is 0.	0	00
180	B4		0	00
181	B5		0	00
182	B6		0	00
183	B7		0	00
184	B8		0	00
185	B9		0	00
186	BA		0	00
187	BB		0	00
188	BC		0	00
189	BD		0	00
190	BE		0	00
191	BF		0	00
192	C0		0	00
193	C1		0	00
194	C2		0	00
195	C3		0	00
196	C4		0	00
197	C5		0	00
198	C6		0	00
199	C7		0	00
200	C8		0	00
201	C9		0	00
202	CA		0	00
203	CB		0	00
204	CC		0	00
205	CD		0	00
206	CE	0	00	
207	CF	0	00	
208	D0	0	00	
209	D1	0	00	
210	D2	0	00	
211	D3	0	00	
212	D4	0	00	
213	D5	0	00	
214	D6	0	00	
215	D7	0	00	

Technical Reference Note

DS1200-3 FRU (EEPROM) Data:

OFFSET		DEFINITION	SPEC VALUE	
(DEC)	(HEX)	(REMARKS)	(DEC)	(HEX)
INTERNAL USE AREA, 40 BYTES				
216	D8	RESERVED, Default value is 0.	0	00
217	D9		0	00
218	DA		0	00
219	DB		0	00
220	DC		0	00
221	DD		0	00
222	DE		0	00
223	DF		0	00
224	E0		0	00
225	E1		0	00
226	E2		0	00
227	E3		0	00
228	E4		0	00
229	E5		0	00
230	E6		0	00
231	E7		0	00
232	E8		0	00
233	E9		0	00
234	EA		0	00
235	EB		0	00
236	EC		0	00
237	ED		0	00
238	EE		0	00
239	EF		0	00
240	F0		0	00
241	F1		0	00
242	F2		0	00
243	F3		0	00
244	F4		0	00
245	F5		0	00
246	F6		0	00
247	F7		0	00
248	F8		0	00
249	F9		0	00
250	FA		0	00
251	FB		0	00
252	FC		0	00
253	FD		0	00
254	FE		0	00
255	FF		Zero CHECKSUM of Internal Use Area (if used). Default Value=0	0

Technical Reference Note

DS1200-3-002 FRU (EEPROM) deviations:

OFFSET		DEFINITION (REMARKS)	SPEC VALUE	
(DEC)	(HEX)		(DEC)	(HEX)
PRODUCT INFORMATION AREA, 56 BYTES				
PRODUCT NAME BYTES (12 Byte sequence)				
50	32	"D" = 44h	68	44
51	33	"S" = 53h	83	53
52	34	"1" = 31h	49	31
53	35	"2" = 32h	50	32
54	36	"0" = 30h	48	30
55	37	"0" = 30h	48	30
56	38	"-" = 2Dh	45	2D
57	39	"3" = 33h	51	33
58	3A	"-" = 2Dh	45	2D
59	3B	"0" = 30h	48	30
60	3C	"0" = 30h	48	30
61	3D	"2" = 32h	50	32
PRODUCT PART/MODEL NUMBER BYTES				
63	3F	"D" = 44h	68	44
64	40	"S" = 53h	83	53
65	41	"1" = 31h	49	31
66	42	"2" = 32h	50	32
67	43	"0" = 30h	48	30
68	44	"0" = 30h	48	30
69	45	"-" = 2Dh	45	2D
70	46	"3" = 33h	51	33
71	47	"-" = 2Dh	45	2D
72	48	"0" = 30h	48	30
73	49	"0" = 30h	48	30
74	4A	"2" = 32h	50	32
PRODUCT SERIAL NUMBER BYTES				
Model ID = H884				
79	4F	"H" = 48h	72	48
80	50	"8" = 38h	56	38
81	51	"8" = 38h	56	38
82	52	"4" = 34h	52	34
Multi Record Area, 88 Bytes				
Power Supply Record Header				
96	60	Record type = 00 for Power supply	0	00
97	61	End of List /Record Format Version Number	2	02
98	62	Record Length of Power Supply Record	24	18
99	63	256-(sum of bytes 101 to 124)	134	86
100	64	Header CHECKSUM of Power Supply Record Header (Zero CHECKSUM) (256-(sum of bytes 96 to 99))	96	60
Combined Wattage,				
Byte 1: 0010 0000 = 20H =32d				
Bits 7-4: 0010B --->(5v --voltage 1)				
Bits 3-0: 0000B --->(12v ---voltage 2)				
Byte 2 and Byte 3:				
1200W =4B0H				
byte 2 (LSB) = B0h =176d				
byte 3 (MSB) =04h = 04d				
121	79	3 Bytes Sequence	32	20
122	7A	In Decimal = 32d, 176d, 04d	176	B0
123	7B	In Hex = 20h,B0h,04h	4	04

DS1200-3-002 FRU (EEPROM) deviations:

OFFSET		DEFINITION (REMARKS)	SPEC VALUE	
(DEC)	(HEX)		(DEC)	(HEX)
5VSB OUTPUT RECORD HEADER				
143	8F	Record type = 01 for DC Output Record	1	01
144	90	End of List /Record Format Version Number for 5VSB Output Record	2	02
145	91	Record Length of 5VSB Output Record	13	0D
146	92	Record CHECKSUM of 5VSB Output Record (Zero CHECKSUM) (256-(sum of bytes 148 to 160))	169	A9
147	93	Header CHECKSUM of 5VSB Output Record Header (Zero CHECKSUM) (256-(sum of bytes 143 to 146))	71	47
5VSB OUTPUT RECORD				
149	95	Nominal Voltage (10mV) , (5.0V / 10mV) 5000 = 01F4h 2 Bytes Sequence In Decimal: 244, 001 In Hex: F4h, 01h	244	F4
150	96		1	01
151	97	Maximum Negative Voltage Deviation (10mV) , (4.75V/10mV) 475 = 01DBh 2 Bytes Sequence In Decimal: 219, 001 In Hex: DBh, 01h	219	0B
152	98		1	01
153	99	Maximum Positive Voltage Deviation (10mV) , (5.25V/ 10mV) 525 = 020Dh 2 Bytes Sequence In Decimal: 013, 002 In Hex: 0DH, 02H	13	0D
154	9A		2	02
159	9F	Maximum Current Draw (10mA) , (4.0A / 10mA) 400 = 0190H 2 Bytes Sequence In Decimal: 144, 001 In Hex: 90H, 01H	144	90
160	A0		1	01

Technical Reference Note

DS1200-3-003 FRU (EEPROM) deviations :

OFFSET		DEFINITION (REMARKS)	SPEC VALUE	
(DEC)	(HEX)		(DEC)	(HEX)
PRODUCT NAME BYTES (12 Byte sequence)				
50	32	"D" = 44h	68	44
51	33	"S" = 53h	83	53
52	34	"1" = 31h	49	31
53	35	"2" = 32h	50	32
54	36	"0" = 30h	48	30
55	37	"0" = 30h	48	30
56	38	"-" = 2Dh	45	2D
57	39	"3" = 33h	51	33
58	3A	"-" = 2Dh	45	2D
59	3B	"0" = 30h	48	30
60	3C	"0" = 30h	48	30
61	3D	"3" = 33h	51	33
PRODUCT PART/MODEL NUMBER BYTES				
63	3F	"D" = 44h	68	44
64	40	"S" = 53h	83	53
65	41	"1" = 31h	49	31
66	42	"2" = 32h	50	32
67	43	"0" = 30h	48	30
68	44	"0" = 30h	48	30
69	45	"-" = 2Dh	45	2D
70	46	"3" = 33h	51	33
71	47	"-" = 2Dh	45	2D
72	48	"0" = 30h	48	30
73	49	"0" = 30h	48	30
74	4A	"3" = 33h	51	33
PRODUCT SERIAL NUMBER BYTES				
Model ID = H884				
79	4F	"I" = 49h	72	48
80	50	"8" = 38h	56	38
81	51	"7" = 37h	55	37
82	52	"7" = 37h	55	37
Multi Record Area, 88 Bytes				
Power Supply Record Header				
96	60	Record type = 00 for Power supply	0	00
97	61	End of List /Record Format Version Number	2	02
98	62	Record Length of Power Supply Record	24	18
99	63	256-(sum of bytes 101 to 124)	134	86
100	64	Header CHECKSUM of Power Supply Record Header (Zero CHECKSUM) (256-(sum of bytes 96 to 99))	96	60
Combined Wattage,				
Byte 1: 0010 0000 = 20H =32d				
Bits 7-4: 0010B --->(5v --voltage 1)				
Bits 3-0: 0000B --->(12v ---voltage 2)				
Byte 2 and Byte 3:				
1200W =4B0H				
byte 2 (LSB) = B0h =176d				
byte 3 (MSB) =04h = 04d				
121	79	3 Bytes Sequence	32	20
122	7A	In Decimal = 32d, 176d, 04d	176	B0
123	7B	In Hex = 20h,B0h,04h	4	04

DS1200-3-003 FRU (EEPROM) deviations:

OFFSET		DEFINITION (REMARKS)	SPEC VALUE	
(DEC)	(HEX)		(DEC)	(HEX)
3V3SB OUTPUT RECORD HEADER				
143	8F	Record type = 01 for DC Output Record	1	01
144	90	End of List /Record Format Version Number for 3V3SB Output Record	2	02
145	91	Record Length of 3V3SB Output Record	13	0D
146	92	Record CHECKSUM of 3V3SB Output Record (Zero CHECKSUM) (256-(sum of bytes 148 to 160))	169	A9
147	93	Header CHECKSUM of 3V3SB Output Record Header (Zero CHECKSUM) (256-(sum of bytes 143 to 146))	71	47
3V3SB OUTPUT RECORD				
149	95	Nominal Voltage (10mV) , (3.3V / 10mV) 330 = 014AH 2 Bytes Sequence In Decimal: 074, 001 In Hex: 4AH, 01H	74	4A
150	96		1	01
151	97	Maximum Negative Voltage Deviation (10mV) , (3.14V/10mV) 314= 013AH 2 Bytes Sequence In Decimal: 058, 001 In Hex: 3AH, 01H	58	3A
152	98		1	01
153	99	Maximum Positive Voltage Deviation (10mV) , (3.46V/ 10mV) 346 =015AH 2 Bytes Sequence In Decimal: 090, 001 In Hex: 5AH, 01H	90	5A
154	9A		1	01
159	9F	Maximum Current Draw (10mA) , (6.0A / 10mA) 600 = 0258H 2 Bytes Sequence In Decimal: 88, 002 In Hex: 58H, 02H	88	58
160	A0		2	02

Technical Reference Note

DS1200-3-004 FRU (EEPROM) deviations :

OFFSET		DEFINITION (REMARKS)	SPEC VALUE	
(DEC)	(HEX)		(DEC)	(HEX)
PRODUCT INFORMATION AREA, 56 BYTES				
PRODUCT NAME BYTES (12 Byte sequence)				
50	32	"D" = 44h	68	44
51	33	"S" = 53h	83	53
52	34	"1" = 31h	49	31
53	35	"2" = 32h	50	32
54	36	"0" = 30h	48	30
55	37	"0" = 30h	48	30
56	38	"-" = 2Dh	45	2D
57	39	"3" = 33h	51	33
58	3A	"-" = 2Dh	45	2D
59	3B	"0" = 30h	48	30
60	3C	"0" = 30h	48	30
61	3D	"4" = 34h	52	34
PRODUCT PART/MODEL NUMBER BYTES				
63	3F	"D" = 44h	68	44
64	40	"S" = 53h	83	53
65	41	"1" = 31h	49	31
66	42	"2" = 32h	50	32
67	43	"0" = 30h	48	30
68	44	"0" = 30h	48	30
69	45	"-" = 2Dh	45	2D
70	46	"3" = 33h	51	33
71	47	"-" = 2Dh	45	2D
72	48	"0" = 30h	48	30
73	49	"0" = 30h	48	30
74	4A	"4" = 34h	52	34
PRODUCT SERIAL NUMBER BYTES				
Model ID = H884				
79	4F	"I" = 49h	73	49
80	50	"8" = 37h	55	37
81	51	"2" = 32h	50	32
82	52	"8" = 38h	56	38
Multi Record Area, 88 Bytes				
Power Supply Record Header				
96	60	Record type = 00 for Power supply	0	00
97	61	End of List /Record Format Version Number	2	02
98	62	Record Length of Power Supply Record	24	18
99	63	256-(sum of bytes 101 to 124)	134	86
100	64	Header CHECKSUM of Power Supply Record Header (Zero CHECKSUM) (256-(sum of bytes 96 to 99))	96	60
Combined Wattage,				
Byte 1: 0010 0000 = 20H =32d				
Bits 7-4: 0010B --->(5v --voltage 1)				
Bits 3-0: 0000B --->(12v ---voltage 2)				
Byte 2 and Byte 3:				
1200W =4B0H				
byte 2 (LSB) = B0h =176d				
byte 3 (MSB) =04h = 04d				
121	79	3 Bytes Sequence	32	20
122	7A	In Decimal = 32d, 176d, 04d	176	B0
123	7B	In Hex = 20h,B0h,04h	4	04

DS1200-3-004 FRU (EEPROM) deviations:

OFFSET		DEFINITION (REMARKS)	SPEC VALUE	
(DEC)	(HEX)		(DEC)	(HEX)
5VSB OUTPUT RECORD HEADER				
143	8F	Record type = 01 for DC Output Record	1	01
144	90	End of List /Record Format Version Number for 5VSB Output Record	2	02
145	91	Record Length of 5VSB Output Record	13	0D
146	92	Record CHECKSUM of 5VSB Output Record (Zero CHECKSUM) (256-(sum of bytes 148 to 160))	169	A9
147	93	Header CHECKSUM of 5VSB Output Record Header (Zero CHECKSUM) (256-(sum of bytes 143 to 146))	71	47
5VSB OUTPUT RECORD				
149	95	Nominal Voltage (10mV) , (5.0V / 10mV) 5000 = 01F4h 2 Bytes Sequence In Decimal: 244, 001 In Hex: F4h, 01h	244	F4
150	96		1	01
151	97	Maximum Negative Voltage Deviation (10mV) , (4.75V/10mV) 475 = 01DBh 2 Bytes Sequence In Decimal: 219, 001 In Hex: DBh, 01h	219	0B
152	98		1	01
153	99	Maximum Positive Voltage Deviation (10mV) , (5.25V/ 10mV) 525 = 020Dh 2 Bytes Sequence In Decimal: 013, 002 In Hex: 0DH, 02H	13	0D
154	9A		2	02
159	9F	Maximum Current Draw (10mA) , (4.0A / 10mA) 400 = 0190H 2 Bytes Sequence In Decimal: 144, 001 In Hex: 90H, 01H	144	90
160	A0		1	01

PMBus™ Interface Support

The DS1200-3 series power supply is compliant with the industry standard PMBus™ protocol for monitoring and control of the power supply via the I²C interface port.

DS1200-3 Series PMBus™ General Instructions

Equipment Setup

The following is typical I²C communication setup:

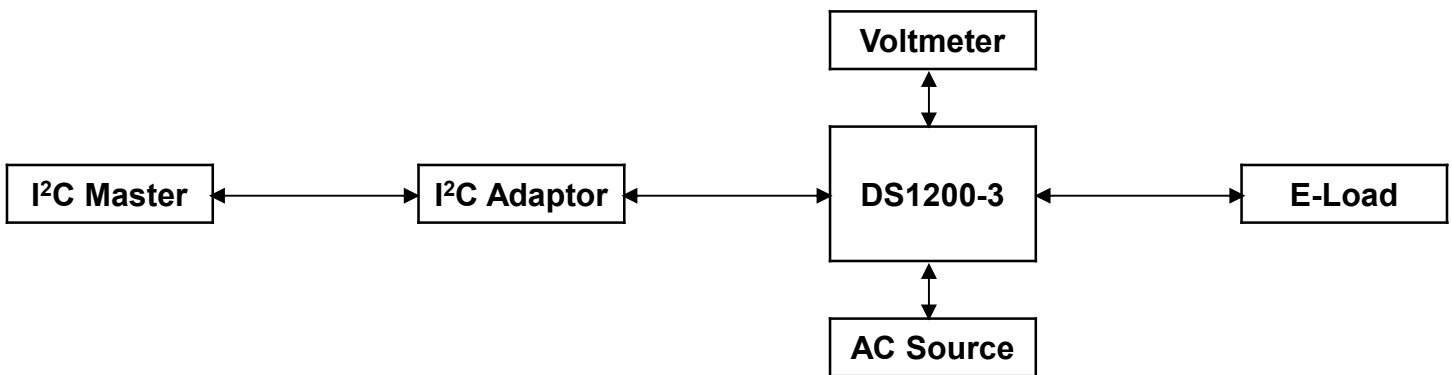

PMBus™ Writing Instructions

When writing to any PMBus™ R/W registers, ALWAYS do the following:

Disable Write Protect (command 10h) by writing any of the following accordingly:

- Levels: 00h – Enable writing to all writeable commands
- 20h – Disables write except 10h, 01h, 00h, 02h and 21h commands
- 40h – Disables write except 10h, 01h, and 00h commands
- 80h – Disable write except 0x00h

To save changes on the USER PMBus™ Table:

Use send byte command: 15h STORE_USER_ALL

To save changes on the DEFAULT PMBus™ Table:

Use send byte command: 11h STORE_DEFAULT_ALL

Wait for 5 seconds, turn-off the PSU, wait for another 5 seconds before turning it on.

DS1200-3 Series Support PMBus™ Command List

The DS1200-3 series power supply is compliant with the industry standard PMBus™ protocol for monitoring and control of the power supply via the i²C interface port.

DS1200-3 Series Supported PMBus™ Command List:

Command Code	Command Name	Default Value	Access Type	Data Bytes	Data Format	Description
01h	OPERATION	80	R/W	1		Used to turn the unit ON/OFF in conjunction with the input PS_ON pin.
	b7:6	10b				00 – Immediate Turn OFF (No Sequencing) 01 – Soft Turn OFF (With Sequencing) 10 – PSU ON
	b5:4	00b				
	b3:2	00b				
	b1:0	00b				Reserved
02h	ON_OFF_CONFIG	1C	R	1		Configures the combination of PS_ON pin and serial communication commands needed to turn the unit ON/OFF.
	b7:5	000				Reserved
	b4 – Enable PS_ON pin and Serial communication control.	1				0 – Unit powers up any time power is present regardless of the state of PS_ON pin. 1 – Unit powers up as dictated by PS_ON pin and OPERATION command (b3:0) .
	b3 – Serial communication Control	1				0 – Unit Ignores ON/OFF portion of the OPERATION command. 1 – Enables Serial communication ON/OFF portion of OPERATION command. Requires PS_ON pin to be asserted for the unit to start and energize the output.
	b2 – Sets how the unit responds to PS_ON pin	1				0 – Unit ignores PS_ON pin. (ON/OFF controlled by OPERATION command). 1 – Unit requires PS_ON pin to be asserted to start the unit.
	b1 – PS_ON pin polarity	0				0 – Active Low (Pull Low to start the unit). 1 – Active high (Pull high to start the unit).
	b0 – PS_ONL pin action	0				0 – Use programmed turn ON/OFF delay. 1 – Turn OFF the output and stop transferring energy to the output as fast as possible.
03h	CLEAR_FAULTS	0	S			
10h	WRITE_PROTECT	00	R/W	1		Used to Control Writing to the PMBus Device 80h - Disables write except 10h 40h – Disables write except 10h, 01h, 00h 20h – Disables write except 10h,01h,00h,02h and 21h commands 00 – Enables write to all writeable commands.
11h	STORE_DEFAULT_ALL	-	S	0		Copies the Value of the Operating memory table to the matching DEFAULT non-volatile memory.
12h	RESTORE_DEFAULT_ALL	-	S	0		Copies the entire contents of the DEFAULT non-volatile memory to the Operating memory table.
15h	STORE_USER_ALL	-	S	0		Copies the Operating memory table to the matching USER non-volatile memory.
16h	RESTORE_USER_ALL	-	S	0		Copies the entire USER non-volatile memory to the Operating memory table.

DS1200-3 Series Supported PMBus™ Command List:

Command Code	Command Name	Default Value	Access Type	Data Bytes	Data Format	Description
19h	CAPABILITY	00	R	1		Provides a way for the hosts system to determine some key capabilities of a PMBus™ device.
	b7 - Packet Error Checking	0				0 - PEC not supported 1 - PEC supported
	b6 - Maximum Bus Speed	1				0 - Maximum supported bus speed, 100khz 1 - Maximum supported bus speed, 400khz
	b5 - SMBALERT#	0				0 – SMBus Alert Pin <i>not supported</i> 1 – SMBus Alert Pin <i>supported</i>
	b4:0	00000				Reserved
20h	VOUT_MODE	40	R	1		Specifies the mode and parameters of Output Voltage related Data Formats
21h	VOUT_COMMAND	B004	R/W	2	Direct	Sets the Output Voltage Reference Vout command sends discreet value to change or trim output voltage. The value acts as Digital reference of the Power supply after additional operations are performed (to make the representation compatible). Affects OVP_WARNING and FAULT LIMIT, as well as POWER_GOOD_ON/OFF level.
22h	VOUT_TRIM	0000	R/W	2		0
23h	VOUT_CAL_OFFSET	XXXX	R/W	2		Variable. Used by Factory to trim Vout Default before trimming, 0000.
24h	VOUT_MAX	6405	R	2	Direct	Sets the max adjustable output voltage limit. 13.8V.
30h	COEFFICIENTS	-	BR	6		Use to retrieve the m, b and R coefficients, needed for DIRECT data format
	byte 1:2	0501				m low Byte, m high byte
	byte 3:4	0000				b low Byte, b high byte
	byte 5	0002				R byte
31h	POUT_MAX	070B	R	2	Linear	Sets the operating power limit condition. 1550W
35h	VIN_ON	C0EA	R	2	Linear	Sets the value of input, in volts, at which the unit should start. ACGOOD 88Vac
36h	VIN_OFF	9EF8	R	2	Linear	Sets the value of input, in volts, at which the unit should stop power conversion. ACBAD 79Vac
38h	IOUT_CAL_GAIN	FF7F	R	2		The ratio of voltage across the Current Sense to actual current.
39h	IOUT_CAL_OFFSET	0000	R	2		Used to null any offsets in the current sensing circuit. Normally used in conjunction with the IOUT_SCALE to minimize current sensing error.

DS1200-3 Series Supported PMBus™ Command List:

Command Code	Command Name	Default Value	Access Type	Data Bytes	Data Format	Description
3Ah	FAN_CONFIG_1_2	90	R	1		Used to configure up to 2 fans associated with one PMBus device
	b7	1				1 – Fan is installed in position 1 0 – No Fan is installed in position 1
	b6	0				1 – Fan is commanded in RPM 0 – Fan is commanded in DC
	b5:4	01				00 – 1 pulse per revolution 01 – 2 pulses per revolution 10 – 3 pulses per revolution 11 – 4 pulses per revolution
	b3	0				1 – Fan is installed in position 2 0 – No Fan is installed in position 2
	b2	0				1 – Fan is commanded in RPM 0 – Fan is commanded in DC
	b1:0	00				00 – 1 pulse per revolution 01 – 2 pulses per revolution 10 – 3 pulses per revolution 11 – 4 pulses per revolution
3Bh	FAN_COMMAND_1	6400	R/W	2	Direct	Adjusts the operation of the Fans. The device may override the command, if it requires higher value, to maintain proper device temperature. RPM Control – Commands Speeds from 0-65535 RPM. Duty cycle Control – Commands Speeds from 0 to 100%
40h	VOUT_OV_FAULT_LIMIT	6405	R/W	2	Direct	Sets Output Over voltage threshold. (13.8V)
41h	VOUT_OV_FAULT_RESPONSE	80	R	1		Unit Latches OFF. Resets on PSON or CONTROL pin recycle or AC recycle.
42h	VOUT_OV_WARN_LIMIT	1405	R/W	2	Direct	Sets Over-voltage Warning threshold. (13V)
43h	VOUT_UV_WARN_LIMIT	4C04	R/W	2	Direct	Sets Under-voltage Warning threshold. (11V)
44h	VOUT_UV_FAULT_LIMIT	FC03	R/W	2	Direct	Sets Under-voltage Fault threshold. (10.2V)
45h	VOUT_UV_FAULT_RESPONSE	80	R	1		Turn PSU OFF
46h	IOUT_OC_FAULT_LIMIT	D430 High 4826 Low	R	2	Direct	Sets the Over current threshold in Amps. (125A for Hi Line and 98A for Low Line)
47h	IOUT_OC_FAULT_RESPONSE	C0	R	1		OCP ride through. If OCP persists.
4Ah	IOUT_OC_WARN_LIMIT	C02B high 6022 Low	R	2	Direct	Sets the Over Current Warning threshold in Amps. (112A for Hi Line and 88A for Low Line)
4Fh	OT_FAULT_LIMIT	A816	R	2	Direct	Secondary ambient temperature Fault threshold, in degree C. (58degC)
50h	OT_FAULT_RESPONSE	B8	R	1		Turn PSU OFF and will retry indefinitely
51h	OT_WARN_LIMIT	70E3	R	2	Direct	Secondary ambient temperature warning threshold, in degree C. Operating limit. refer to section 3.1. (55 degC)
55h	VIN_OV_FAULT_LIMIT	26FA	R	2	Linear	Sets input over-voltage threshold. (275Vac)
56h	VIN_OV_FAULT_RESPONSE	00	R	1		No interruption.
57h	VIN_OV_WARN_LIMIT	26FA	R	2	Linear	Sets the threshold of input voltage that triggers high voltage warning. (275Vac)
58h	VIN_UV_WARN_LIMIT	90EA	R	2	Linear	(82Vac)
59h	VIN_UV_FAULT_LIMIT	80EA	R	2	Linear	(80Vac)
5Ah	VIN_UV_FAULT_RESPONSE	00	R	1		
5Bh	IIN_OC_FAULT_LIMIT	40D3	R	2	Linear	Sets the threshold for input current that causes over-current fault within 100ms. (13A)

Technical Reference Note

DS1200-3 Series Supported PMBus™ Command List:

Command Code	Command Name	Default Value	Access Type	Data Bytes	Data Format	Description
5Ch	IIN-OC-FAULT_RESPONSE	00	R	1		Turn PSU OFF. cleared upon AC recycle.
5Eh	POWER_GOOD_ON	9804	R	2	Direct	Sets the threshold by which the Power Good signal is asserted. (11.76V)
5Fh	POWER_GOOD_OFF	FC03	R	2	Direct	Sets the threshold by which the Power Good signal is de-asserted. (10.2V)
60h	TON_DELAY	C300	R	2	Direct	Sets the time (sec), from start condition (Power ON) until the output starts to rise. (2sec)
61h	TON_RISE	8813	R	2	Direct	Sets the time (ms), for the output rises from 0 to regulation. (50ms)
64h	TOFF_DELAY	FC08	R	2	Direct	Sets the time (ms), from a stop condition (Power OFF) until the output starts to drop (converter OFF).(23ms)
78h	STATUS_BYTE		R	1		Returns the summary of critical faults
	b7 – BUSY					A fault was declared because the device was busy and unable to respond.
	b6 – OFF					Unit is OFF
	b5 – VOUT_OV					Output over-voltage fault has occurred
	b4 – IOUT_OC					Output over-current fault has occurred
	b3 - VIN_UV					An input under-voltage fault has occurred
	b2 - TEMPERATURE					A temperature fault or warning has occurred
	b1 – CML					A communication, memory or logic fault has occurred.
	b0 – NONE OF THE ABOVE					A Fault Warning not listed in bits[7:1] has occurred.
79h	STATUS_WORD		R	2		Summary of units Fault and warning status.
	b15 – VOUT					An output voltage fault or warning has occurred
	b14 – IOUT/POUT					An Output current or power fault or warning has occurred.
	b13 – INPUT					An input voltage, current or power fault or warning as occurred.
	b12 – MFR					A manufacturer specific fault or warning has occurred.
	b11 – POWER_GOOD#					The POWER_GOOD signal is de-asserted
	b10 - FANS					A fan or airflow fault or warning has occurred.
	b9 – OTHER					A bit in STATUS_OTHER is set.
	b8 – UNKNOWN					A fault type not given in bits [15:1] of the STATUS_WORD has been detected.
	b7 – BUSY					A fault was declared because the device was busy and unable to respond.
	b6 – OFF					Unit is OFF
	b5 – VOUT_OV					Output over-voltage fault has occurred
	b4 – IOUT_OC					Output over-current fault has occurred
	b3 - VIN_UV					An input under-voltage fault has occurred
	b2 – TEMPERATURE					A temperature fault or warning has occurred
b1 – CML					A communication, memory or logic fault has occurred.	
b0 – NONE_OF_THE_ABOVE					A fault or warning not listed in bits[7:1] of this byte has occurred.	

DS1200-3 Series Supported PMBus™ Command List:

Command Code	Command Name	Default Value	Access Type	Data Bytes	Data Format	Description
7Ah	STATUS_VOUT	-	R	1		Output voltage related faults and warnings
	b7					VOUT Over-voltage Fault
	b6					VOUT Over-voltage warning
	b5					VOUT Under-voltage Warning
	b4					VOUT Under-voltage Fault
	b3					VOUT_MAX Warning, an attempt has been made to set output to a value higher than the highest permissible voltage.
	b2					TON_MAX_FAULT
	b1					TOFF_MAX Warning
	b0					reserved
7Bh	STATUS_IOUT		R	1		Output Current related faults and warnings
	b7					IOUT Over current Fault
	b6					IOUT Over current And Low Voltage shutdown Fault
	b5					IOUT Overcurrent Warning
	b4					IOUT Undercurrent Fault
	b3					Current Share Fault Set if Ishare level is much greater or lower than the actual output current. Refer to Output Specifications (Table 3) for Current sharing limits.
	b2					Power Limiting
	b1					POUT Overpower Fault
	b0					POUT Overpower Warning
7Ch	STATUS_INPUT		R	1		Input related faults and warnings
	b7					VIN Overvoltage Fault
	b6					VIN Overvoltage Warning
	b5					VIN Undervoltage Warning
	b4					VIN Undervoltage Fault
	b3					Unit is OFF for insufficient Input Voltage
	b2					IIN Overcurrent Fault
	b1					IIN Overcurrent Warning
	b0					PIN overpower Warning
7Dh	STATUS_TEMPERATURE	-	R	1		Temperature related faults and warnings
	b7					Overtemperature Fault
	b6					Overtemperature Warning
	b5					Undertemperature Warning
	b4					Undertemperature Fault
	b3:0					reserved
7Eh	STATUS_CML	-	R	1		Communications, Logic and Memory
	b7					Invalid or unsupported Command Received
	b6					
	b5					Packet Error Check Failed
	b4					Memory Fault Detect, CRC Error
	b3					
	b2					
	b1					
	b0					

DS1200-3 Series Supported PMBus™ Command List:

Command Code	Command Name	Default Value	Access Type	Data Bytes	Data Format	Description
80h	STATUS_MFR_SPECIFIC	-	R	1		Manufacturer Status codes
	b7					Bulk OK, 1- Bulk is within range and is ready for use
	b6					Not Used
	b5					Not Used
	b4					Not Used
	b3					Not Uesd
	b2					Not Uesd
	b1					Standby Fault, 1 If there's a standby fault.
	b0					PS_ON Pin Status 1 – asserted, 0 - deasserted
81h	STATUS_FANS_1_2	-	R	1		
	b7					Fan 1 Fault
	b6					Fan 2 Fault
	b5					Fan 1 Warning
	b4					Fan 2 Warning
	b3					Fan_1 Speed Overridden
	b2					Fan_2 Speed Overridden
	b1					
	b0					
88h	READ_VIN	-	R	2	Linear	Returns input Voltage in Volts ac.
89h	READ_IIN	-	R	2	Linear	Returns input Current in Amperes
8Ah	READ_VCAP	-	R	2	Linear	Returns Bulk Capacitor voltage in Volts
8Bh	READ_VOUT	-	R	2	Direct	Returns the actual, measured voltage in Volts.
8Ch	READ_IOUT	-	R	2	Direct	Returns the output current in amperes.
8Eh	READ_TEMPERATURE_2	-	R	2	Direct	PSU Air inlet temp (inside PSU)
90h	READ_FAN_SPEED_1	-	R	2	Linear	Speed of Fan 1
96h	READ_POUT	-	R	2	Linear	Returns the output power, in Watts.
97h	READ_PIN	-	R	2	Linear	Returns the input power, in Watts.
98h	PMBUS_REVISION	11	R	1		Reads the PMBus revision number
	b7:5	0001				Part 1 Revision 0000 – Revision 1.0 0001 – Revision 1.1
	b4:0	0001				Part 2 Revision0000 – Revision 1.00001 – Revision 1.1
99h	MFR_ID	“ALL”	BR, ASCII	4		Abbrev or symbol of manufacturers name.
9Ah	MFR_MODEL	“DS1200-3”	BR, ASCII	8		Manufacturers Model number, ASCII format
9Bh	MFR_REVISION	“1.0”	BR, ASCII	3		Manufacturers, revision number, ASCII format
9Ch	MFR_LOCATION	“xxx”	BR, ASCII	4		Manufacturers facility, ASCII format
9Dh	MFR_Data	“xxxxxxx”	BR	7		Manufacture Date, ASCII format structure : YYMMDD
9Eh	MFR_Serial	“xxxxxxxxxxxxx”	BR	13		Unit serial number, ASCII format.
A0h	MFR_VIN_MIN	B4F8	R	2	Linear	Minimum Input Voltage (90Vac)
A1h	MFR_VIN_MAX	10FA	R	2	Linear	Maximum Input Voltage (264Vac)
A2h	MFR_IIN_MAX	18F8	R	2	Linear	Maximum Input Current (12A)

DS1200-3 Series Supported PMBus™ Command List:

Command Code	Command Name	Default Value	Access Type	Data Bytes	Data Format	Description
A3	MFR_PIN_MAX	A20A ^{HI} 4C0A ^{LO}			Linear	Maximum Input Power (1348W for High Line and 1176W for Low Line)
A4h	MFR_VOUT_MIN	7404	R	2	Direct	Minimum Output Voltage Regulation Window. (11.4V)
A5h	MFR_VOUT_MAX	EC04	R	2	Direct	Maximum Output Voltage. Regulation Window (12.6V)
A6h	MFR_IOUT_MAX	7026 ^{HI} E01F ^{LO}	R	2	Direct	Maximum Output Current (98.4A for High Line and 81.6 for Low Line)
A7h	MFR_POOUT_MAX	580A ^{HI} E803 ^{LO}	R	2	Linear	Maximum Output Power (1200W for High Line and 1000 For Low Line)
A8h	MFR_TAMBIENT_MAX	8813	R	2	Direct	Maximum Operating Ambient Temperature (Secondary Ambient) (50 degC)
A9h	MFR_TAMBIENT_MIN	0000	R	2	Direct	Minimum Operating Ambient Temperature (Secondary Ambient) (0 degC)
D1h	STBY_UV	C409	R	2	Direct	Standby Under-voltage Level (2.5V, For conversion decimal value should be multiplied by 10, eg. 2.5V x10 = 25V = 09C4hex)
D2h	Min Fan Speed	3923	R	2	L	Standby Fan Speed, (13200 rpm / 20% Duty Cycle)
D3h	Max Fan Speed	5832	R	2	L	Normal operation Fan Speed (38400 rpm / 100% Duty Cycle)
E2h	Ishare Offset		R/W	2		Variable. Used by Factory to trim Ishare Voltage Offset. Default before trimming, 0000
E3h	Ishare Slope		R/W	2		Variable. Used by Factory to trim Ishare Voltage Slope. Default before trimming, FF7F
EAh	ENTER_BOOTLOAD		W	2		
EEh	FIRMWARE_VERSION		BR	11	ASCII	
EFh	I/O_EXPANDER		R	1		See Section 5.24.6 – Power Supply Status Register
F0h	MFR_PASSWORD		W	2		
F1h	MFR_DATE_WRITE		BW	6	-	
F2h	MFR_SERIAL_WRITE		BW	13	-	
D0h	Fault Register		R	2		Summary of units Fault and warning status.
	b15 – 12Vout_sckt					An output short circuit fault has occurred.
	b14 – 12Vout_ocw					+12V Over Current Warning Flag
	b13 – 12Vout_ocp2					+12V Fast OCP (High Level OCP) fault occurred (1ms)
	b12 – 12Vout_ocp					+12V Normal OCP fault occurred (1sec).
	b11 – 12Vout_ovp2					+12V Second level OVP fault occurred.
	b10 - 12Vout_ovp					+12V OVP fault occurred.
	b9 – 12Vout_uvp					+12V UVP fault occurred.
	b8 – NA					Not Used
	b7 – NA					Not Used
	b6 – Ocp_ride_through_flag					PSU is in 1second ride-through because +12V OCP level is reached.

DS1200-3 Series Supported PMBus™ Command List:

Command Code	Command Name	Default Value	Access Type	Data Bytes	Data Format	Description
D0	b5 – stby_uvp					Standby UVP fault occurred.
	b4 – fanfail					A fan or airflow fault or warning has occurred.
	b3 – otp_secondary					Secondary OTP (Ambient) fault occurred.
	b2 – otp_primary					Primary OTP fault occurred.
	b1 – PwrLimit_Enabled.					PSU is on Derated Output Power
	b0 – Save Last Known State IFF "1" - default "0"					Saves Last Known Fault that Occurred. Under Development
F7h	Calibration Register		R	1		PSU is Calibrated and Passed all Functional Tests
	b7 – PSU Calibrated and Tested					Bit is set if PSU Calibrated and has Passed all Functional Tests. This is to ensure that all PSUs exiting the factory have been calibrated.
	b6 – NA					Not Used
	b5 – NA					Not Used
	b4 – NA					Not Used
	b3 - NA					Not Used
	b2 - NA					Not Used
	b1 – NA					Not Used
	b0 – NA					Not Used

Application Notes

Current Sharing

The DS1200-3 series' main output V_O is equipped with current sharing capability. This will allow up to 4 power supplies to be connected in parallel for higher power application. Current share accuracy is typically 5% of full load. When supplying light loads between 10% and 40% of its rated load, the power supplies will share within 20% accuracy. Below 10% total loading, there is no guarantee of output current sharing.

Redundancy / Fault Tolerance

The DS1200-3 series power supplies will allow up to 4 power supplies to be connected in an N+1 redundant load.

Any failure of one power supply in parallel as well as hot swapping shall not cause more than a 5% change in any output. The Failure of one or more supplies will not cause the remaining supplies to violate any of the input or output specifications noted in this specification including all status signals.

The latch of the DS1200-3 power supply is designed to prevent the latch from depressed if the AC cord is attached to the power supply. In order to remove the power supply from system chassis, the AC cord must be removed first so the power supply will always be in the powered off state during the removal from system chassis.

Output Ripple and Noise Measurement

The setup outlined in the diagram below has been used for output voltage ripple and noise measurements on the DS1200-3 series power supply. When measuring output ripple and noise, a scope jack in parallel with a $0.1\mu\text{F}$ ceramic chip capacitor, and a $10\mu\text{F}$ aluminum electrolytic capacitor should be used. Oscilloscope should be set to 20MHz bandwidth for this measurement.

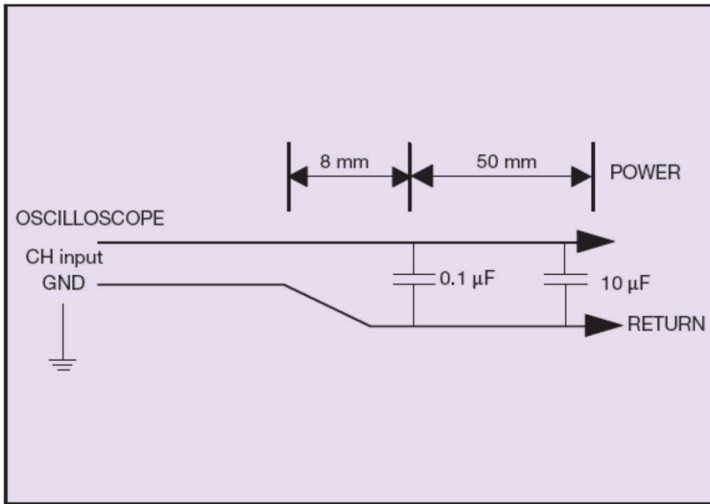

Record of Revision and Changes

Issue	Date	Description	Originators
1.8	06.05.2017	Latest Update	K. Wang
1.9	04.16.2020	Updated the description for 30h command	K. Wang
2.0	05.27.2020	Update safety cert 60950 to 62368	K. Wang

WORLDWIDE OFFICES

Americas

2900 South Diablo Way
 Suite B100
 Tempe, AZ 85282
 USA
 +1 888 412 7832

Europe (UK)

Ground Floor Offices
 Barberrry House, 4 Harbour Buildings
 Waterfront West, Brierley Hill
 West Midlands, DY5 1LN, UK
 +44 (0) 1384 842 211

Asia (HK)

14/F, Lu Plaza
 2 Wing Yip Street
 Kwun Tong, Kowloon
 Hong Kong
 +852 2176 3333



For more information: www.artesyn.com
 For support: productsupport.ep@artesyn.com

Artesyn Embedded Technologies, Artesyn Embedded Power, Artesyn, and all Artesyn related logos are trademarks and service marks of Artesyn Embedded Technologies, Inc. All other names and logos referred to are trade names, trademarks, or registered trademarks of their respective owners. Specifications are subject to change without notice. © 2019 Artesyn Embedded Technologies, Inc. All rights reserved. For full legal terms and conditions, please visit www.artesyn.com/legal.